

CHEM-FEED[®]

Multi-Diaphragm Metering Pump



Series CD1

Fluid metering solutions made simple[®]

1.0	Introduction	4
	1.1 Available Models	4
	1.2 What's in the Box	4
2.0	Engineering Specifications	5
3.0	Materials of Construction	6
	3.1 Wetted Components	6
	3.2 Non-Wetted Components	6
4.0	Features	7
	4.1 Agency Listings	7
5.0	Installation	8
	5.1 Mounting Location	8
	5.2 Pump Dimensions	8
	5.3 Wall Mounting	9
	5.4 Power Connections	10
	5.5 Input / Output Connections	12
	5.6 M12 Connections	13
6.0	Touchpad Layout	14
7.0	Set-Up, Programming, and Inputs	15
	7.1 Remote Start / Stop	15
	7.2 Programming FVS (Flow Verification Sensor)	16
	7.3 Pump Lockout	17
	7.4 4-20ma Input	18
8.0	Pump Operation	19
	8.1 Priming the Pump	19
	8.2 Manual Speed/Flow Adjust	20
	8.3 4-20ma Speed/Flow Control	21
9.0	Outputs	22
	9.1 Motor ON	22
	9.2 Relay (FVS and TFD)	22
	9.3 4-20mA Output	22
10.0	Diaphragm Failure Detection (DFD)	22
	10.1 Confirming Chemical Detection	22
11.0	Pump Maintenance	23
	11.1 Routine Inspection and Maintenance	23
	11.2 Cleaning and Lubricating the Pump	23
12.0	Firmware Update	24
13.0	Replacement Parts List	26
	14.1 Exploded View	27
14.0	Accessories	28
15.0	Troubleshooting	30
16.0	Warranty	31
APPENDIX A: ACRONYMS		32
APPENDIX B: MODEL NUMBER MATRIX		33

READ THE ENTIRE OPERATING MANUAL PRIOR TO INSTALLATION AND USE.



+1 (714) 893 - 8529



sales@blue-white.com



customerservice@blue-white.com



5300 Business Drive
Huntington Beach, CA 92649

1.0 INTRODUCTION

Congratulations on purchasing the CD1 variable speed Multi-Diaphragm Metering Pump.

Please Note: Your new pump has been pressure tested at the factory with clean water before shipping.

1.1 Available Models

CHEM-FEED® Model Number

CD1	CHEM-FEED® Diaphragm Metering Pump
Control	
F	Standard Control Methods (Manual, Remote, FVS)
V	4-20mA Input, 4-20mA Output, in addition to Standard Control Methods (Manual, Remote, FVS)
Diaphragm and O-Rings Material	
V	DiaFlex® Diaphragms and TFE/P O-Rings (For all chemicals excluding caustic soda and aqueous ammonia)
E	Flex-A-Prene® Diaphragms and EP O-Rings (For caustic soda and aqueous ammonia)
Pump Fittings (Inlet / Outlet)	
B	1/2" ID Barb Straight Fittings
C	1/2" ID Barb Elbow Fittings
S	1/4" x 3/8" Compression Straight Fittings
T	1/4" x 3/8" Compression Elbow Fittings
M	1/2" M/NPT Straight Fittings
X	1/2" M/NPT Elbow Fittings
Power Cord - Removable (Operating voltage requirement 96VAC to 264VAC)	
4	115V 50/60Hz, power cord NEMA 5/15 plug (US)
6	220V 50/60Hz, power cord CEE 7/V11 plug (EU)
X	No Power Cord Provided (Power cord is required - See accessories for power cord options)
CD1 F V B 4	Sample Model Number

4.0 What's In The Box

CD1 Multi-Diaphragm Pump with Top Cover



Wall Mounting Bracket



Discharge Tubing (3/8"x5')
(when ordered with "S" or "T" pump fittings)



Instruction Manual



Suction Tubing (3/8"OD x 5')
(when ordered with "S" or "T" pump fittings)



Installation Kit

- Injection Fitting
- Foot Valve
- Screws
- Ceramic Weight
- Tube Nuts



2.0 ENGINEERING SPECIFICATIONS

Maximum Working Pressure	Up to 150 psig (10.3 bar)*
Maximum Fluid Temperature	Up to 185 °F (85 °C)
Maximum Ambient Temperature	14 °F to 115 °F / -10 °C to 46 °C
Maximum Viscosity	1,000 Centipoise
Maximum Suction Lift	20 ft. at 0 PSI
Operating Voltage Range	100 to 240VAC-50/60Hz
Power Cord Options	115V50/60Hz = NEMA 5/15 (USA)
	230V50/60Hz = NEMA 6/15 (USA)
	220V50/60Hz = CEE 7/VII (EU)
	240V50/60Hz = AS 3112 (Australia/New Zealand)
	230V50/60Hz = BS 1363/A (UK)
Signal Connectors	M12 - 5 pin (IP67 rated connectors on "V" models)
Motor	Brushless DC, 50W
Duty Cycle	Continuous
Turndown Ratio	2,000:1, (0.05% – 100%) Max rpm = 100
Maximum Overall Dimensions	9.5" W x 9.5" H x 10.4" D (24.1 W x 24.1 H x 26.4 D cm)
Product Weight	8.5 lb. (3.8 Kg)
Approximate Shipping Dimensions	10.5" W x 11.75" H x 13" D (26.7 W x 29.8 H x 33 D cm)
Approximate Shipping Weight	15.5 lb. (7.0 Kg)
Enclosure	NEMA 4X (IP66), Valox® (PBT)
RoHS Compliant	Yes
Standards	cETLus, CE

* Refer to "Flow rate vs Pressure" graph for details.

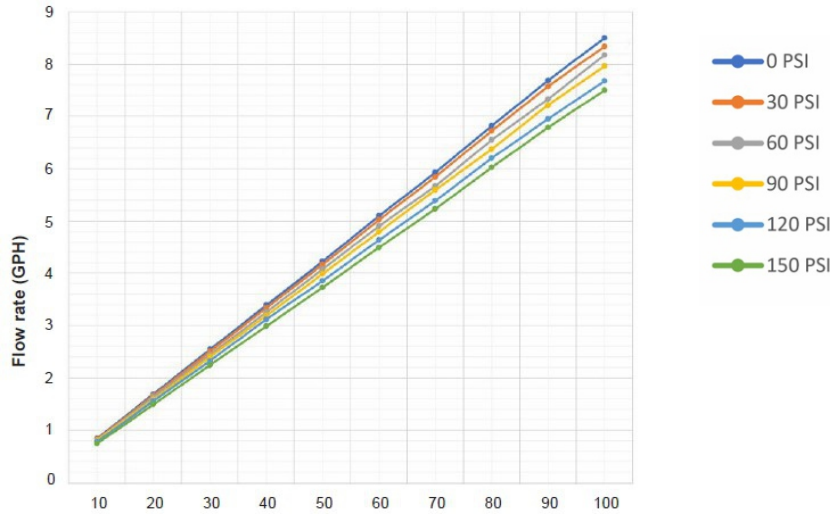

Motor Speed %	Flowrate (Gal/hr), Pressure						Flowrate (mL/min), Pressure					
	0 PSI	30 PSI	60 PSI	90 PSI	120 PSI	150 PSI	0 PSI	30 PSI	60 PSI	90 PSI	120 PSI	150 PSI
	0 Bar	2.1 Bar	4.2 Bar	6.2 Bar	8.3 Bar	10.3 Bar	0 Bar	2.1 Bar	4.2 Bar	6.2 Bar	8.3 Bar	10.3 Bar
10	0.83	0.82	0.81	0.80	0.78	0.74	52.7	51.9	51.0	50.7	48.9	46.5
20	1.68	1.66	1.63	1.58	1.55	1.49	106.3	104.7	102.8	100.0	98.0	93.8
30	2.54	2.50	2.44	2.40	2.32	2.24	160.3	157.9	154.2	151.3	146.6	141.4
40	3.39	3.34	3.26	3.19	3.12	2.99	213.7	210.6	205.4	201.3	196.6	188.6
50	4.23	4.17	4.08	3.99	3.86	3.73	266.8	262.9	257.5	251.9	243.3	235.4
60	5.10	5.02	4.90	4.79	4.63	4.49	321.6	316.9	309.1	302.2	292.4	283.3
70	5.93	5.84	5.67	5.59	5.38	5.23	373.9	368.5	357.6	352.7	339.6	330.0
80	6.82	6.72	6.55	6.37	6.20	6.02	430.2	424.0	413.1	402.1	391.1	379.9
90	7.69	7.58	7.33	7.21	6.95	6.79	485.1	478.0	462.6	455.2	438.4	428.1
100	8.50	8.34	8.18	7.96	7.68	7.50	536.3	526.0	516.0	502.0	484.4	473.3

3.0 MATERIALS OF CONSTRUCTION

3.1 Wetted Components

Pump Head Assembly

Pump Head	PVDF
Adapter Connections	PVDF
Valve Cartridge	PVDF
Valve Balls	Ceramic*
Elastometer	TFE/P (optional EP)
Static Seals	TFE/P (optional EP)
Diaphragm	DiaFlex® (optional Flex-A-Prene®)

Injection / Back-Flow Check Valve

Body & Insert	PVDF
Check Ball	Ceramic
Spring	Hastelloy C-276
Static & Ball Seat O-Ring	TFE/P (optional EP)

Ancillary Items Provided

Suction Tubing	3/8" OD x 1/4" ID x 5' Clear PVC
Discharge Tubing	3/8" OD x 1/4" ID x 5' Polyethylene (LDPE)
Suction Strainer	Polypropylene
Weight	Ceramic

* Teflon Ball Checks/Cartridges are available as accessory items. Contact factory for details.

3.2 Non-wetted Components

Enclosure	Valox® (PBT)
Drive Enclosure	PA12
Pump Head Cover	Polycarbonate
Cover Screws	Stainless steel, polypropylene cap
DFD System Sensor Pins	Hastelloy C-276
Power Cord	3 conductor, SJTW-A water-resistant
Mounting Brackets and Hardware	3/16 stainless steel screws GF nylon bracket

4.0 FEATURES

- > Smooth chemical dosing, no pulsation dampener needed.
- > Automatic Degassing Valve (ADV) System reduced the risk of vapor lock.
- > Diaphragm Failure Detection (DFD) system which senses diaphragm failure.
- > Rated for continuous duty.
- > Compatible with Blue-White Industries, Flow Verification Sensor (FVS) system.
- > Remote Start/Stop - One non-powered dry contact closure.
- > Speed Control: Manual Speed Adjust and Scalable 4-20ma Input (on "V" model)
- > Outputs: 4-20mA, 250V/3A (FVS, DFD) relay, and solid state relay "motor on" (0-60 VDC sinking)
- > Multi diaphragm metering with industry best turndown at 2000:1 (Brushless DC motor)
- > Built for long life at high pressures up to 150 PSI (10.3 bar)
- > Output rates up to 8.50 GPH (32.2 LPH) @ 0 PSI, 8.34 GPH (31.6 LPH) @ 30 PSI, 7.50 GPH (28.4 LPH) @ 150 PSI
- > Convenient M12 Connectors (IP67) for Input/Output Communications. (M12 cables ordered separately)

4.1 Agency Listings



This pump complies to the Machinery Directive 2006/42/EC, BS, EN 60204-1, Low Voltage Directive 2014/35/EU BS EN 61010-1, EMC Directive 2014/30/EU, BS EN 50081-1/BS EN 50082-1.



This pump complies to the Machinery Directive 2006/42/EC, BS, EN 60204-1, Low Voltage Directive 2014/35/EU BS EN 61010-1, EMC Directive 2014/30/EU, BS EN 50081-1/BS EN 50082-1.

Symbol	Description
	Warning (Risk of electric shock)
	Caution (Refer to the user's guide)
	Ground, Protective Conductor Terminal

ENCLOSURE RATING

- NEMA 4X** Constructed for either indoor or outdoor use to provide a degree of protection to personnel against incidental contact with enclosed equipment; to provide a degree of protection against falling dirt, rain, sleet, snow, windblown dust, splashing water, and hose-directed water; and that will be undamaged by external formation of ice on enclosure.
- IP66** No ingress of dust; complete protection against contact. Water projected in powerful jets against enclosure from any direction shall have no harmful effects.

5.0 INSTALLATION

CAUTION



The pump should be serviced by qualified persons only. If equipment is used in a manner not specified in this manual, the protection provided by the equipment may be impaired.

CAUTION



Always wear protective clothing, face shield, safety glasses and gloves when working on or near your metering pump. Additional precautions should be taken depending on solution being pumped. Refer to MSDS precautions from your solution supplier.

CAUTION



All diagrams are strictly for guideline purposes only. Always consult an expert before installing metering pump on specialized systems. Metering pump should be serviced by qualified persons only.

CAUTION



Check system pressure and piping pressure limits before installation. If using pump with chemicals that off-gas (i.e. sodium hypochlorite), do not leave chemicals in pump or between valves for excessive periods of non-use. Flush pump as necessary.

CAUTION



The pump should be supplied by an isolating transformer or RCD (operating current less or equal 30 mA).

5.1 Mounting Location

1. **The pump must be sheltered from environment (rain, snow, direct sunlight, etc.) Do not place pump on floor or in location with excessive chemical spills or vapors.**
2. Choose an area located near the chemical supply tank, chemical injection point, and electrical supply. Also, choose an area where the pump can be easily serviced.

NOTE: Suction and Discharge manifolds can be removed and rotated so the suction and/or discharge connections are on opposite sides. Pump performance will not be affected by suction or discharge location. For best De-gassing and Priming efficiency, locate suction connection on same side as degassing cart.

3. Finding a secure surface and using the provided mounting hardware, mount the pump close to the injection point. Keep the inlet (suction) and outlet (discharge) tubing as short as possible. Longer discharge tubing increases back pressure at pump head.

NOTE: Mounting the pump lower than the chemical container will gravity-feed chemical into it. This "flooded suction" installation will reduce output error due to increased suction lift. A shut-off valve, pinch-clamp, or other means to halt gravity-feed to the pump must be installed during servicing.

NOTE: Install a back flow prevention check valve at the discharge side of the pump to prevent the system fluid from flowing back through pump during maintenance.

NOTE: It is recommended to have a pressure relief valve at the discharge side of the of pump to prevent premature wear and damage to the pump, in the event that the discharge line becomes blocked.

NOTE: The pump does not require back pressure. Back-pressure valve may be desired to maintain consistent flow into inconsistent system pressure.

5.2 Pump Dimensions

Dim	Inch	cm	Dim	Inch	cm
A	9.49"	24.10	F	4.32"	10.98
B	10.15"	25.78	G	6.57"	16.69
C	9.46"	24.02	H	8.87"	22.54
D	7.18"	18.23	I	6.67"	16.94
E	7.18"	18.23			

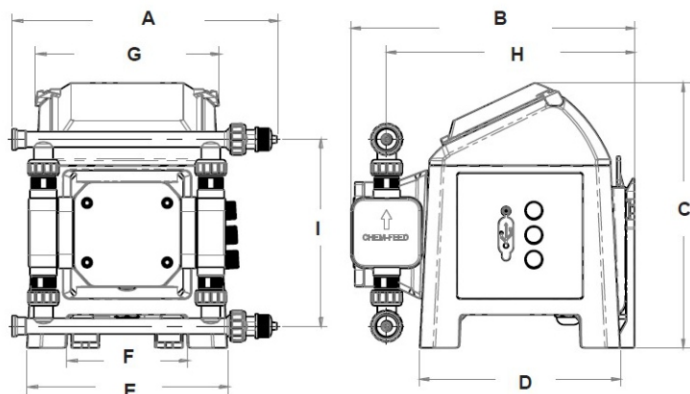

5.3 Wall Mounting

- Using the provided #10 self-tapping screws, mount the bracket to a secure wall that is located where it can be easily serviced.

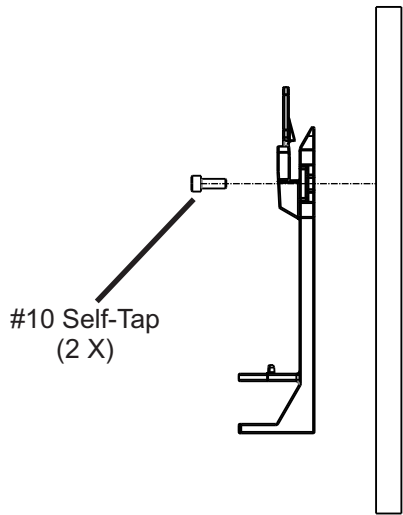

Wall Mount Bracket (Side View)

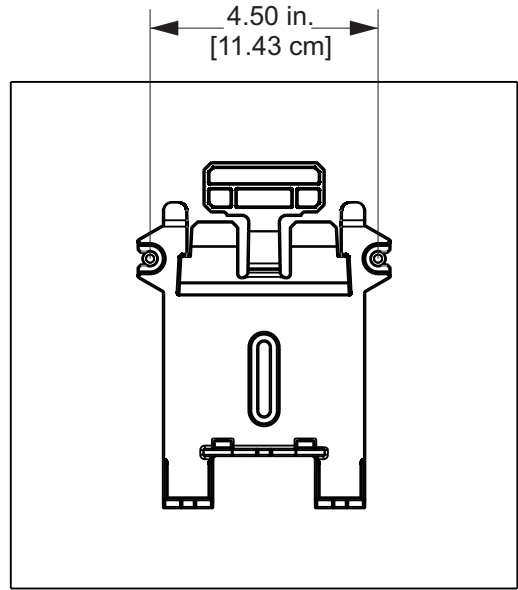

Mounted Pump (Front View)

- Lower the pump so that the tab on the wall mount is inserted into the slot located on the back of the pump. The pump will now be secured to the wall mount bracket. To remove pump, pull tab forward and lift pump.

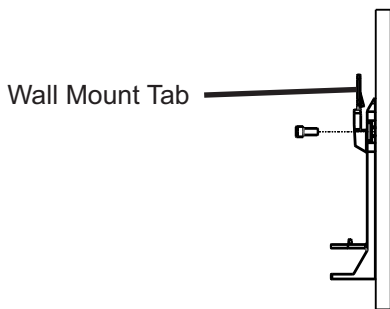
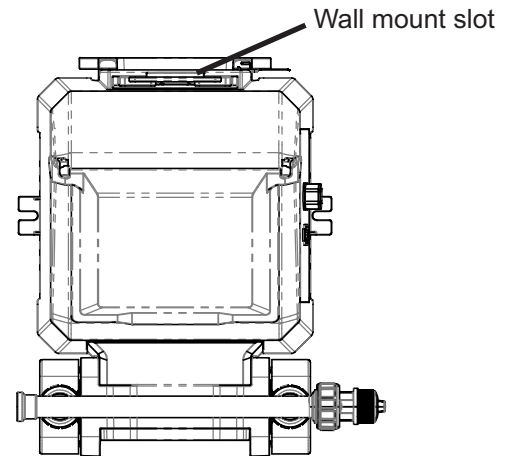
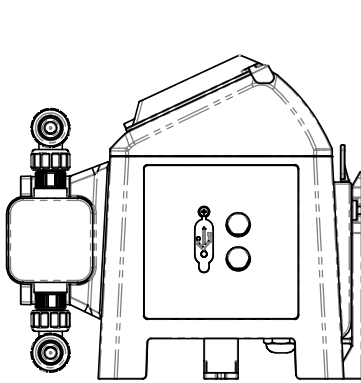

Wall Mount (Side View)

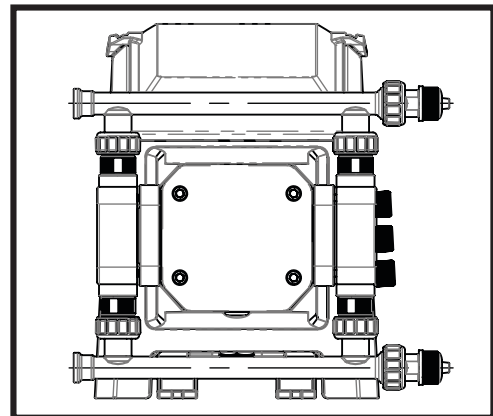

Mounted Pump

5.4 POWER CONNECTIONS

WARNING

Risk of electric shock – cord connected models are supplied with a grounding conductor and grounding-type attachment plug. To reduce risk of electric shock, be certain that it is connected only to a properly grounded, grounding-type receptacle.

WARNING

Electrical connections and grounding (earthing) must conform to local wiring codes.

WARNING

Risk of electric shock - Disconnect electricity before removing wiring compartment cover.

WARNING

Ensure to connect the pump to the proper supply voltage. Using the incorrect voltage will damage the pump and may result in injury. The voltage requirements is printed on the pump serial label.

- ▶ Use the voltage for which the power cord is rated.
- ▶ To prevent electronic noise interference, electronic signal wires and AC power wires must be kept separate. Do not bundle these cables together or run within the same conduit.
- ▶ When there is a power interruption, the pump will restart (resume) in the same state as prior to power interruption.
- ▶ POWER: 115V60Hz (0.6A max.), 220V50Hz (0.3A max.), 230V60Hz (0.3A max.), 230V50Hz (0.3A max.), 240V50Hz (0.3A max.)
- ▶ **COVERS FOR USB CONNECTION AND M12 CONNECTIONS MUST BE IN PLACE WHEN NOT CONNECTED TO CABLES**

NOTE: When in doubt regarding your electrical installation, contact a licensed electrician.



Pump (Right Side Panel) - "V" model shown

5.5 IO Connection



Risk of electric shock - All wiring must be insulated and rated 300V minimum.

COVERS FOR USB CONNECTION AND M12 CONNECTIONS MUST BE IN PLACE WHEN NOT CONNECTED TO CABLES (Failure to keep connectors in place may void warranty)

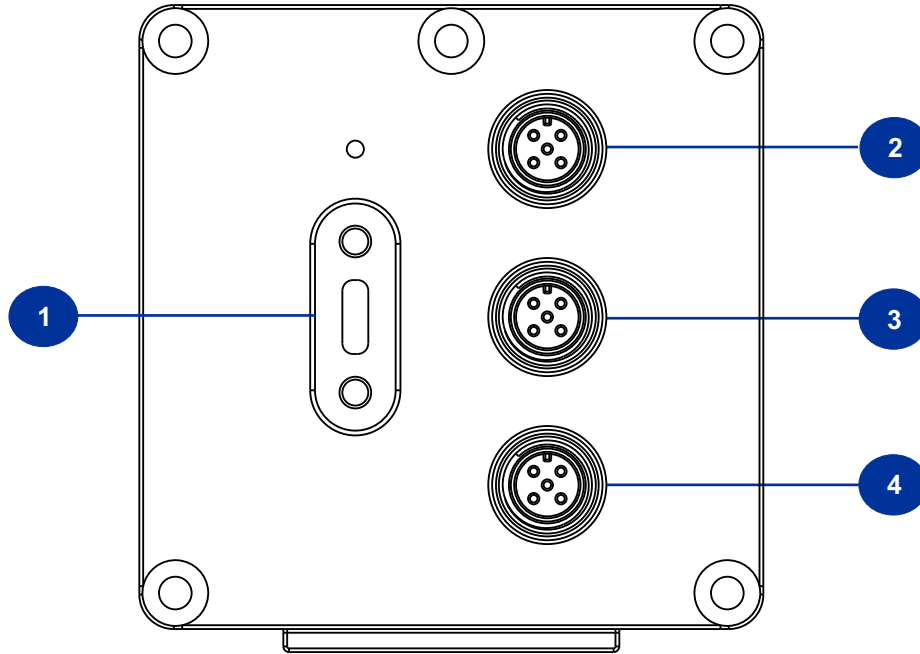

Pump (Right Side Panel)

Item Number	Item
1	USB-C Connector
2	M12 Connector I/O 1 (included with CD1V only)
3	M12 Connector I/O 2
4	M12 Connector I/O 3

M12 connectors not included with product.

*A-Type M12 connector with 5 position female sockets required.
Shielded cable should be used on all signal wires.*

5.6 M12 Connector

Warning! Never allow M12 cable wires to touch while the pump is active. Wiring shorts will cause the pump to malfunction and can void the warranty. Protect or tape unused wires as necessary.

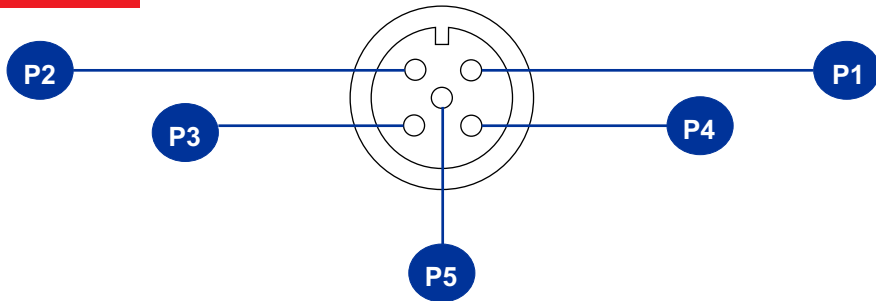

Blue-White M12 Cable Wiring		
DIAGRAM	PIN #	WIRE
	PIN 1	BROWN
	PIN 2	WHITE
	PIN 3	BLUE
	PIN 4	BLACK
	PIN 5	GRAY

M12 Connector I/O 1 (included with CD1V only)

PIN	Function	Specifications	Reference
P1	4-20mA Input (+)	120 Ohm Impedance, Non powered loop	(+) Positive
P2	4-20mA Input (-)	120 Ohm Impedance, Non powered loop	(-) Negative
P3	4-20mA Output (+)	600 Ohm Max Load	(+) Positive
P4	4-20mA Output (-)	DC Ground (0 VDC)	(-) Negative
P5		Not Used	

M12 Connector I/O 2

PIN	Function	Specifications	Reference
P1	Remote Start / Stop	Dry Contact Closure (Do Not add voltage)	Green Light = Normally Open Red Light = Normally Closed
P2	Ground	DC Ground	0 VDC
P3	FVS (+)	15 VDC @ 60 mA	To power FVS sensor
P4	FVS (-)	DC Ground (0 VDC)	FVS Ground Input
P5	FVS (Signal)	Input Signal	Input for FVS Signal

M12 Connector I/O 3

PIN	Function	Specifications
P1	Pump Motor Running (+)	0-60VDC sinking output (+) Solid State Contact Closure
P2	Pump Motor Running (-)	0-60VDC sinking output (-) Solid State Contact Closure
P3	N.O. (closes with DFD or FVS alarm)	Relay Out, N.O. Contact 3 Amp @ 250 VAC
P4	COM	Relay Out, COM Contact
P5	N.C. (opens with DFD or FVS alarm)	Relay Out, N.C. Contact 3 Amp @ 250 VAC

6.0 TOUCHPAD LAYOUT

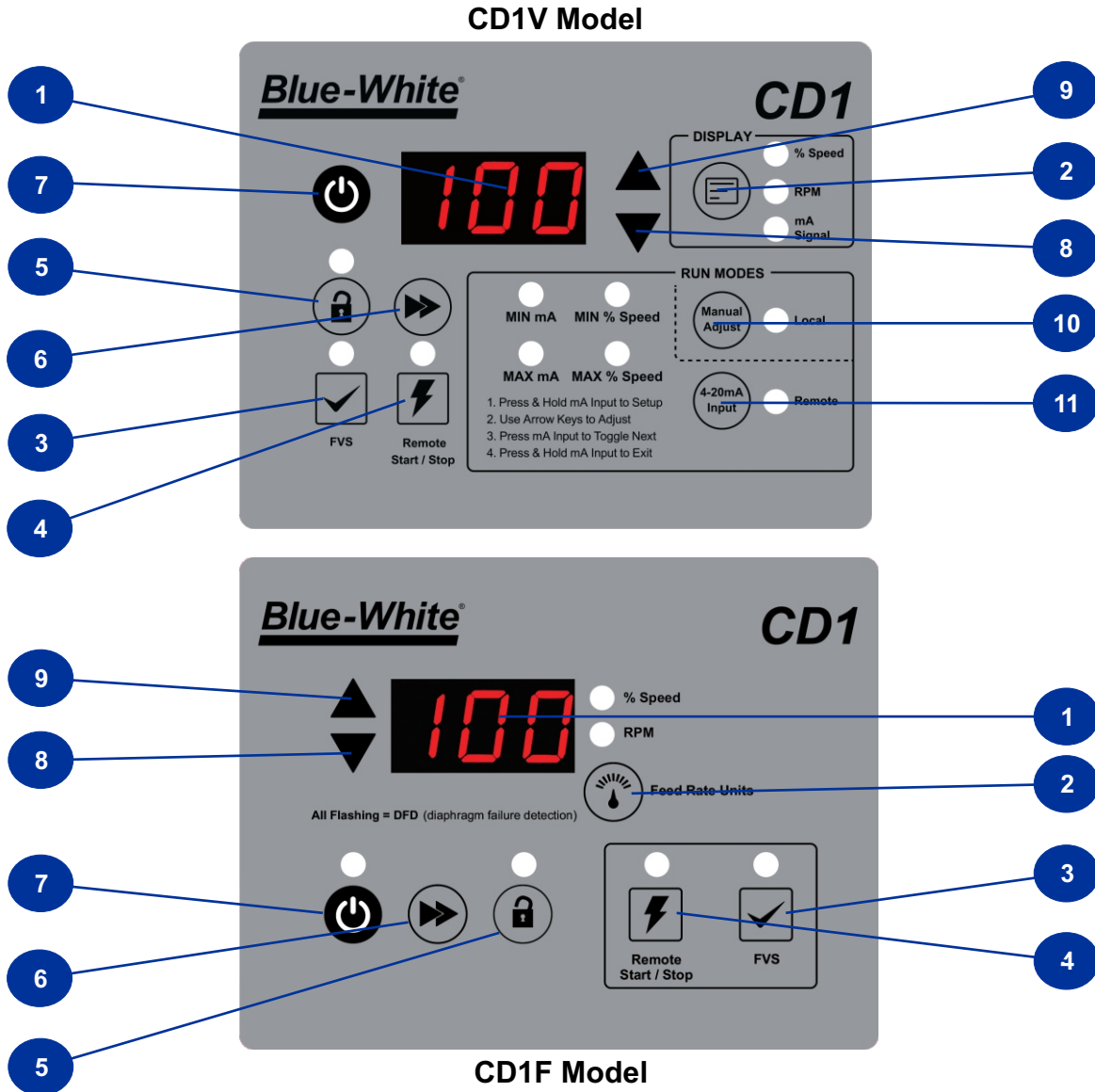

Item Number	Item
1	LED/LCD Readout
2	Rate Display Key
3	Flow Verification Sensor (FVS) Key
4	Remote Start/Stop Key
5	Lock-Out Key
6	Prime Key
7	Start & Stop Key
8	Down Key
9	Up Key
10	Manual Speed Adjust
11	4-20mA

7.2 Programming FVS (Flow Verification Sensor)

Flow Verification System (FVS) uses a pulse signal from flow meter/sensor. When the FVS feature is activated, if running pump does not receive signal/pulse in the programmed delay time, the pump will stop and activate Alarm Output Relay. Display will read “FuS”. (Contact Blue-White for FVS sensor options.)

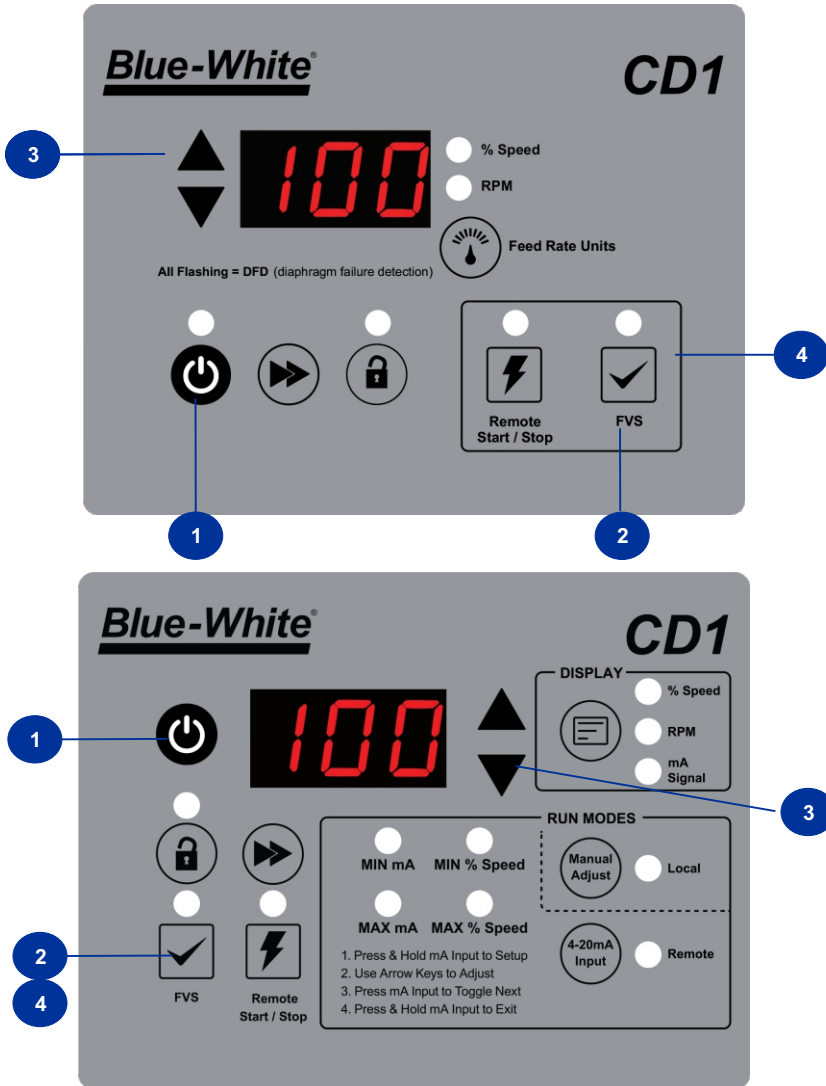

Item Number	Directions for Programming FVS
1	Confirm that pump is in the OFF position
2	Press and hold FVS button (5-7 seconds)
3	Toggle up/down arrow to set Delay Time
4	Press and hold FVS button (5-7 seconds)

Activate by pressing FVS button once. Light On indicates activation. Press again to de-activate.

NOTE: Alarm Delay Time range 1-20 seconds

7.3 Pump Lockout

Pump Lockout feature allows the user to “lock out” the ability to change pump controls, such as Pump Speed, Prime, FVS, Remote Start/Stop, Manual/4-20ma Modes. User will still be able to start and stop the pump.

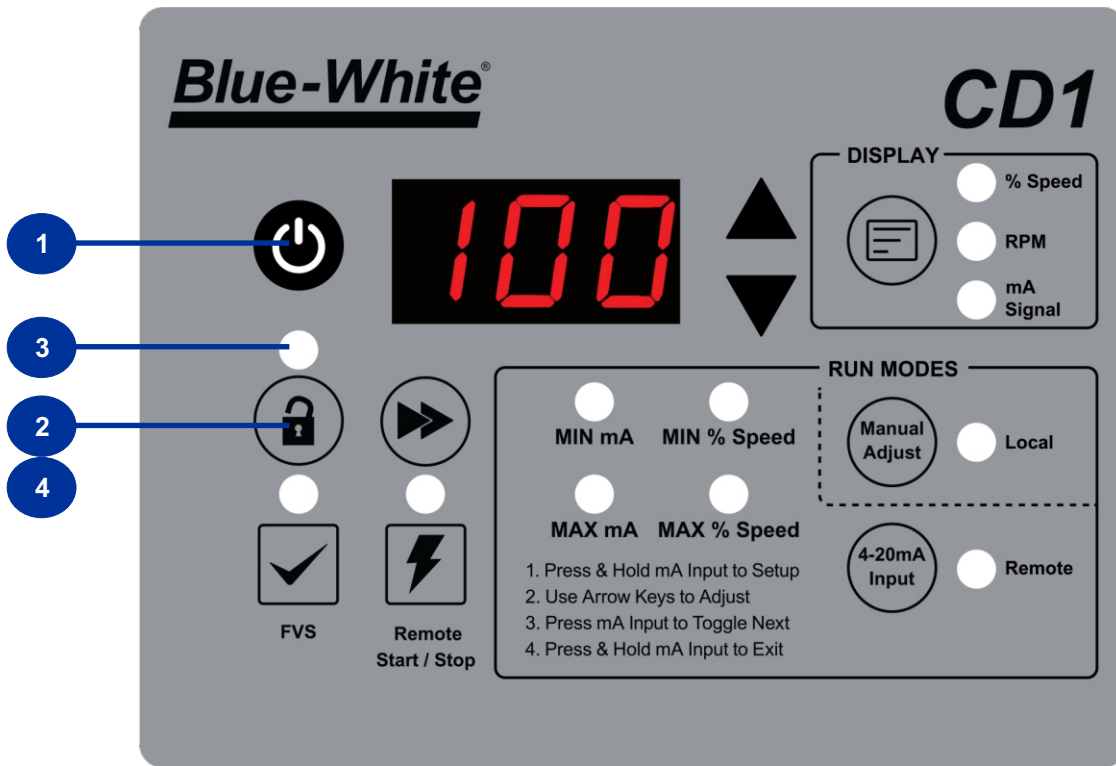

Item Number	Directions
1	Pump can be running or in the OFF position
2	Press and hold Lockout button (5-7 seconds)
3	Light will activate
4	To de-activate, press and hold Lockout button (5-7 seconds)

7.4 4-20mA Input (With “V” Model Only)

Selecting 4-20mA input mode

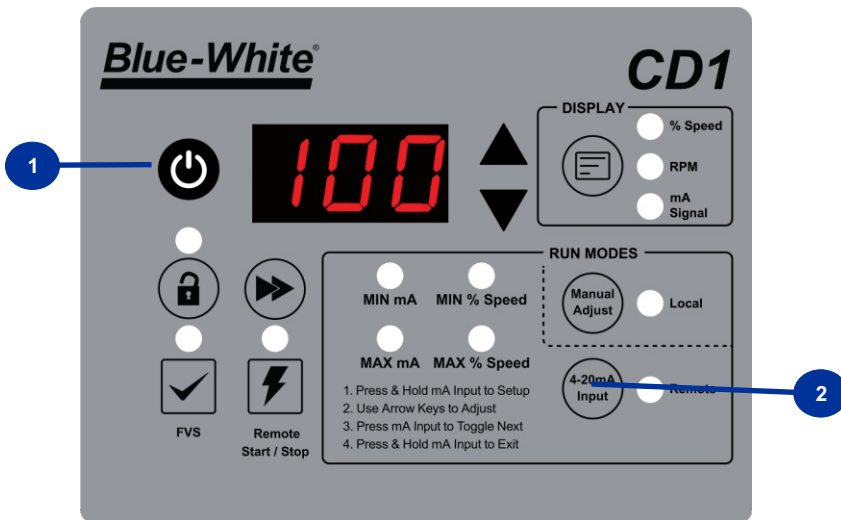

Directions

- 1 Confirm that pump is in the OFF position
- 2 Press 4-20mA Input button

Programming 4-20mA input mode

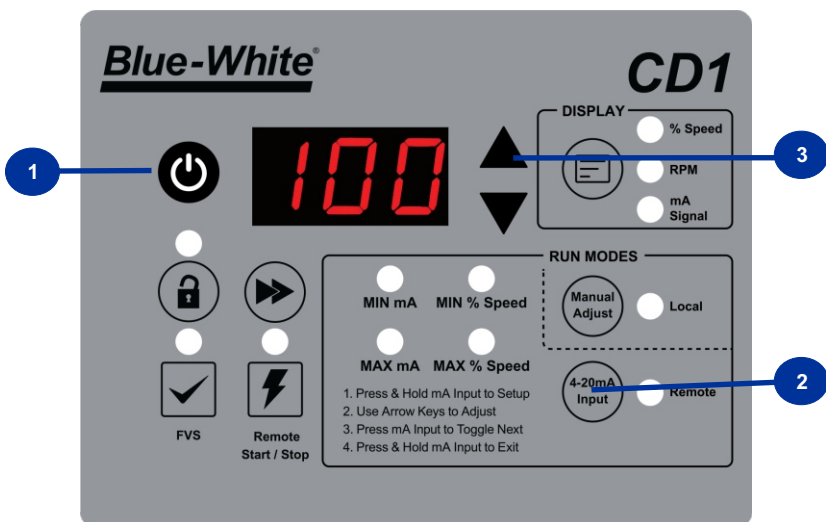

Directions

- 1 Confirm that pump is in the OFF position.
- 2 Press and hold 4-20mA Input button. MIN mA light will illuminate. Use arrow keys to toggle min mA value for the pump to operate at
- 3 Press 4-20mA Input button for MIN % Speed light to illuminate
- 4 Use arrow keys to toggle MIN % Speed value for the pump to operate.
- 5 Press 4-20mA Input button for MAX mA light to illuminate.
- 6 Use arrow keys to toggle MAX mA value for the pump to operate.
- 7 Press 4-20mA Input button for MAX % Speed light to illuminate.
- 8 Use arrow keys to toggle MAX % Speed value for the pump to operate.
- 9 Press and hold 4-20mA Input button to exit programming mode.

8.0 PUMP OPERATION

8.1 Priming The Pump

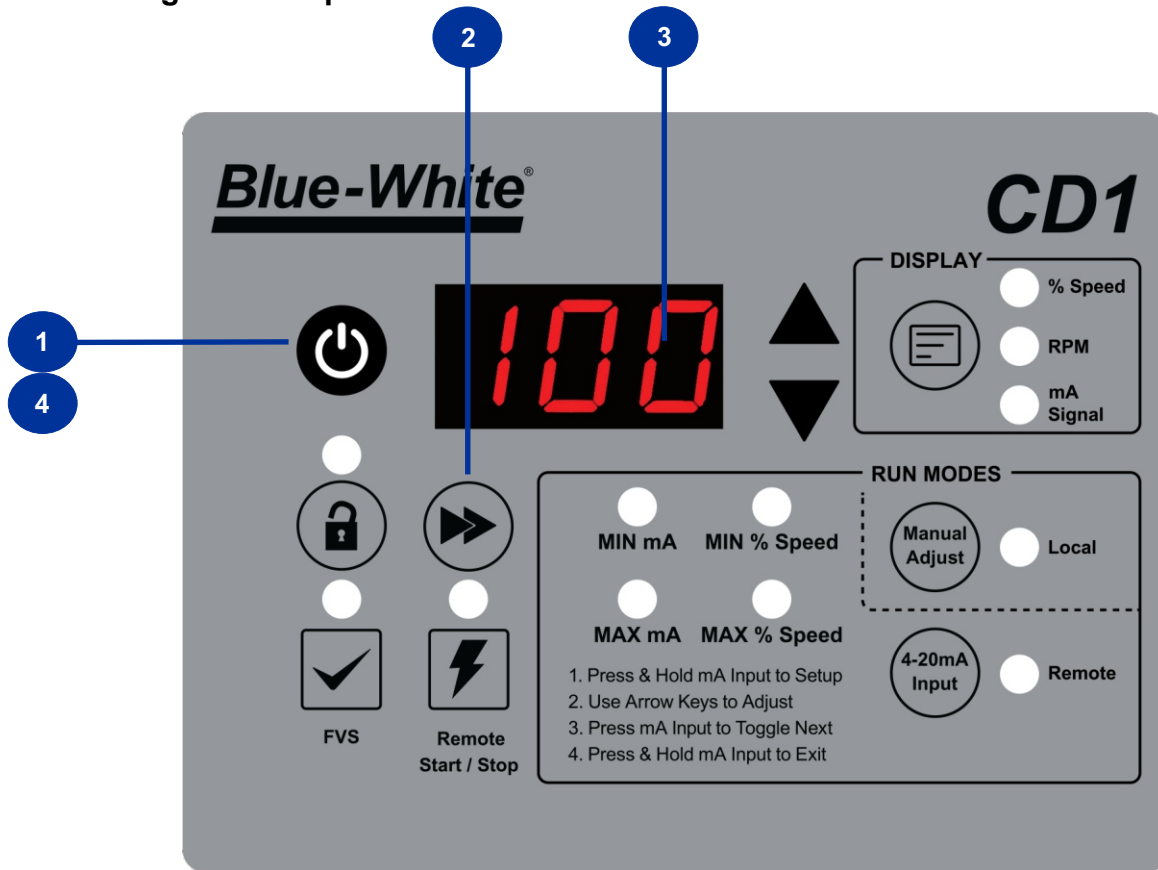

Item Number	Directions
1	Pump can be running or in the OFF position
2	Press Prime button
3	Pumps will run at 100% speed and Display will count down from 60 seconds
4	Press Start/Stop button at any time to Stop pump

Need help calibrating your pump?
 Click on ... or scan the QR code.



8.2 Manual Speed/Flow Adjust

Pump speed can be adjusted manually using “Manual Adjust” Run Mode.

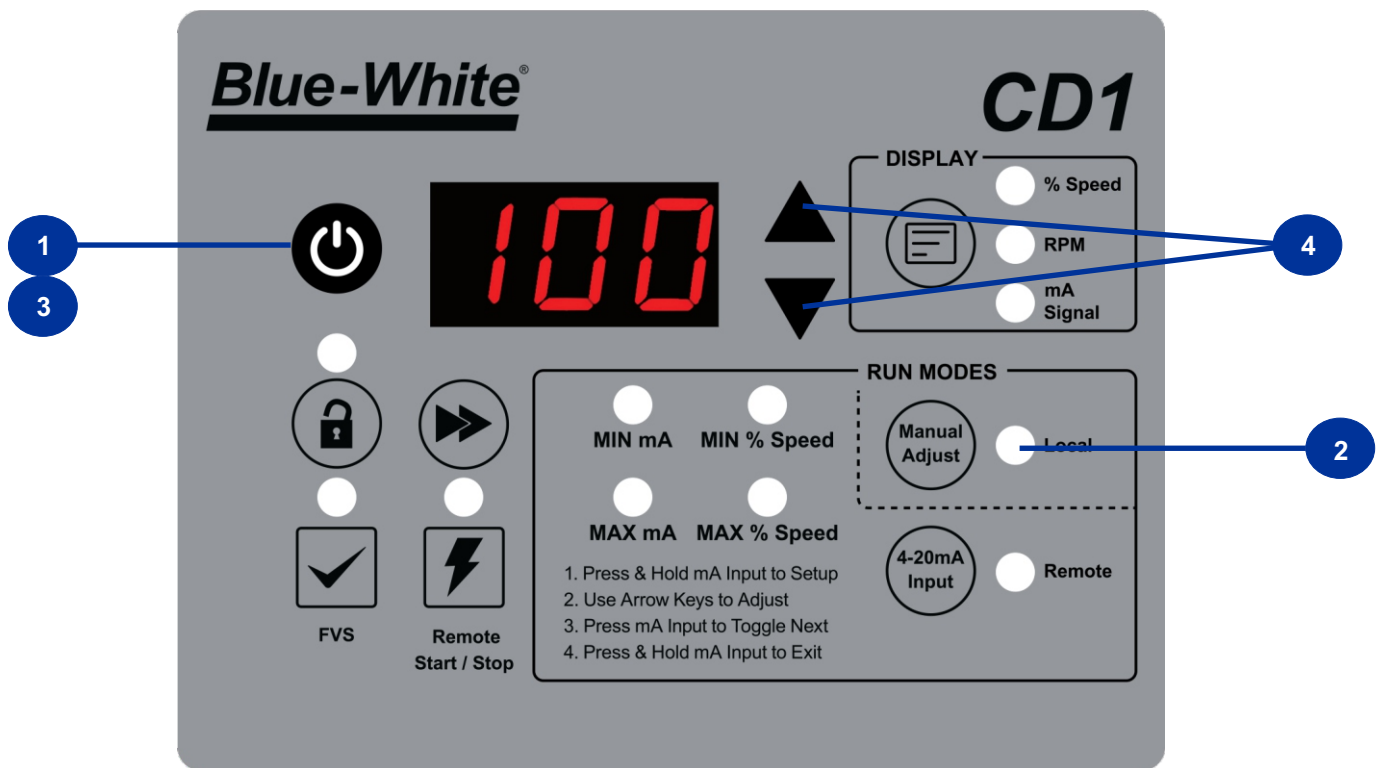

Item Number	Directions
1	Confirm that pump is in the OFF position
2	Press “Manual Adjust” button. Local light will activate.
3	Press Start/Stop button.
4	Adjust pump speed using up and down arrows

8.3 4-20 Input Speed/Flow Control (With “V” Model Only)

Pump speed can be adjusted remotely using “4-20ma Input” Run Mode.

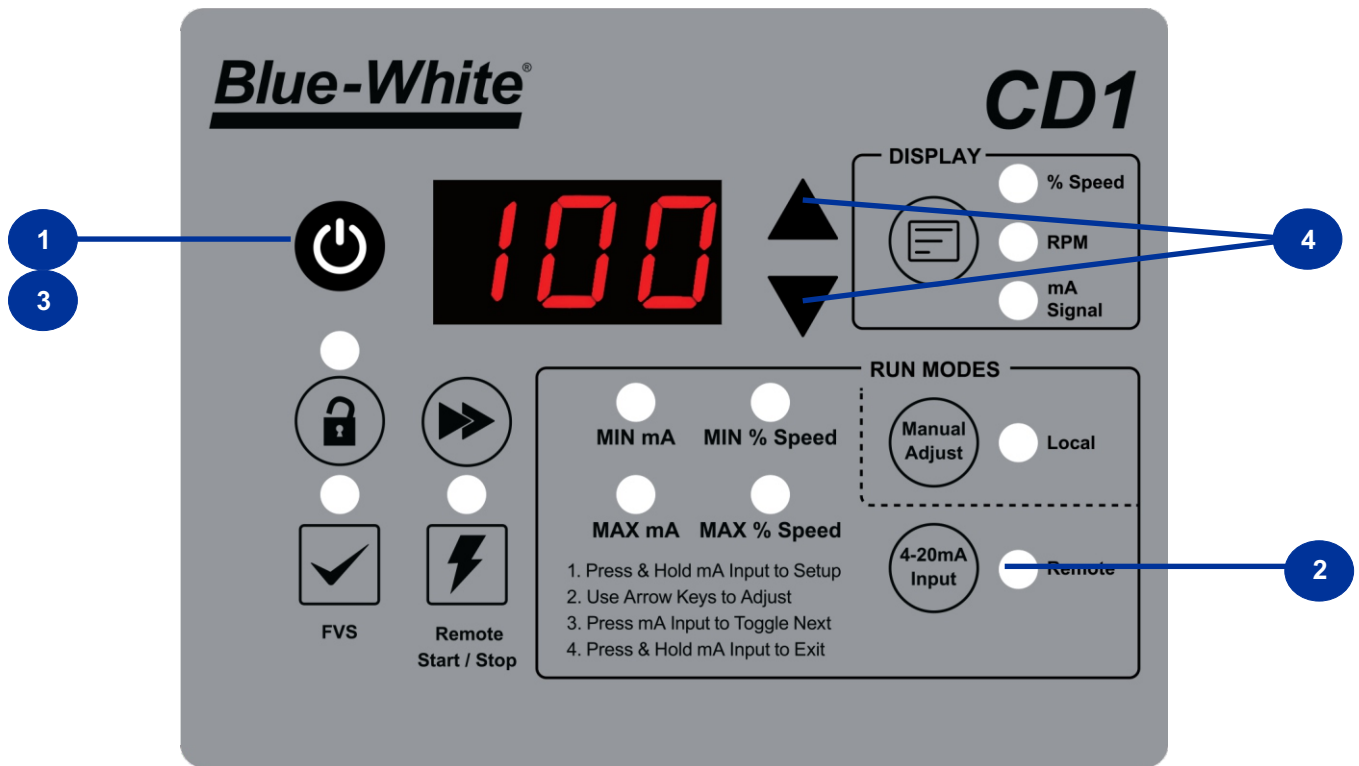

Item Number	Directions
1	Confirm that pump is in the OFF position
2	Press “4-20ma Input” button. Remote light will activate.
3	Press Start/Stop button.
4	Pump speed will be adjusted by 4-20ma input signal
5	Adjust up and down arrows to display % speed, RPM, or 4-20mA input signal

9.0 OUTPUTS

- MOTOR ON** - Active when motor is running in Manual or 4-20ma Mode.
- RELAY OUTPUT** - Active when either DFD or FVS has triggered. Stop pump to reset.
- 4-20 mA OUTPUT** - Non-scalable full scale output proportional to pump speed.

10.0 DFD (Diaphragm Failure Detection)

This system is capable of detecting presence of a large number of chemicals including Sodium Hypochlorite (Chlorine), Hydrochloric (muriatic) Acid, Sodium Hydroxide, and many others. System will not be triggered by water (rain, condensation, etc.) or lubricants.

If DFD alarm occurs, pump will stop, close an alarm output, and screen will flash DFD with an alarm icon.

If system has detected chemical, pump diaphragm must be replaced and pump head must be thoroughly cleaned. To clean the DFD pins, remove cover on bottom of drive chamber by removing two screws. You can now clean the pins in this area. (pump may need to be removed from mounting bracket for better access. Failure to clean pump head will void warranty.

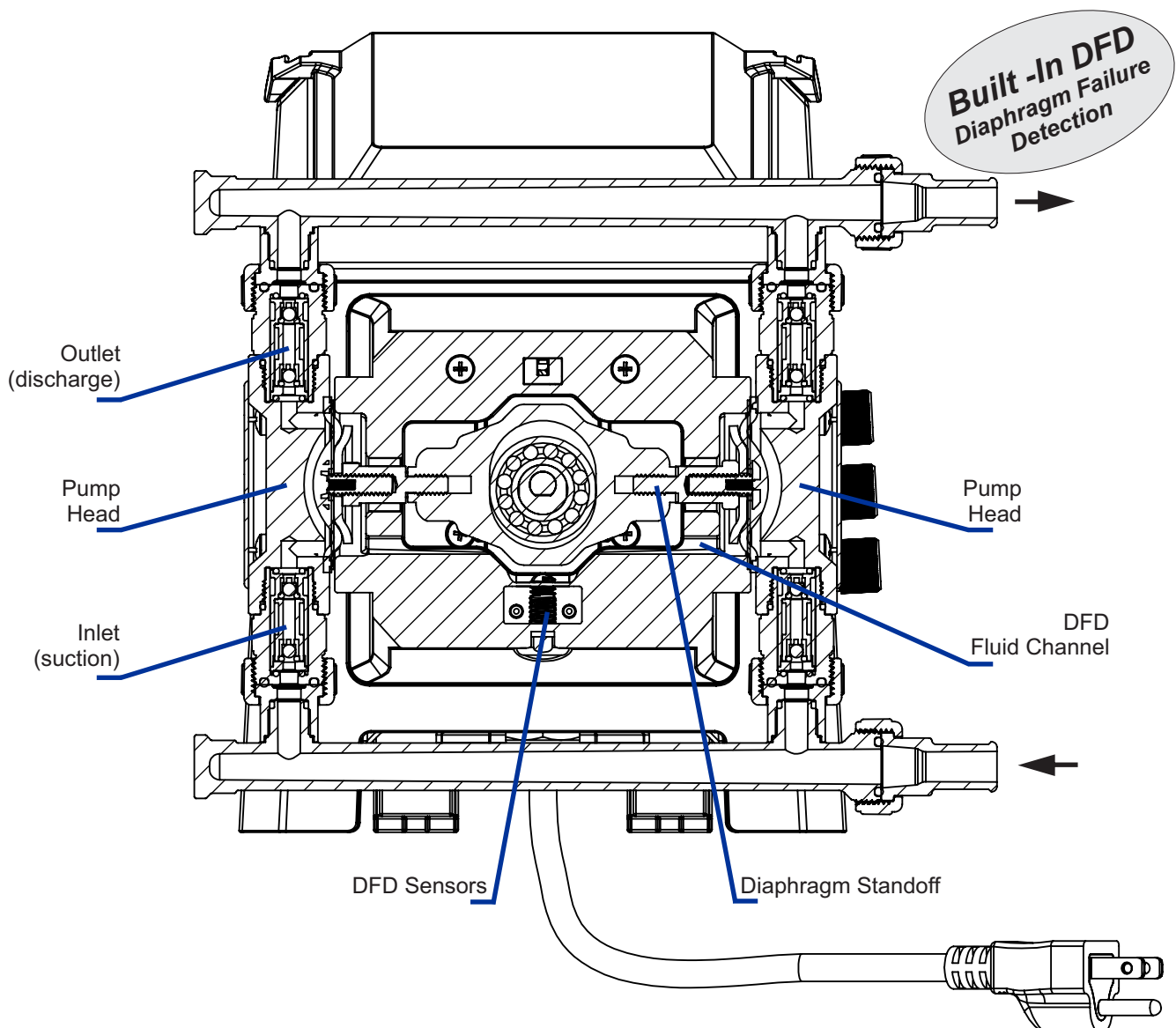

11.0 Pump Maintenance

CAUTION



Prior to service, pump clean water through pump and suction / discharge line to remove chemical.

CAUTION



Always wear protective clothing, face shield, safety glasses and gloves when working on or near your metering pump. Additional precautions should be taken depending on solution being pumped. Refer to MSDS precautions from your solution supplier.

11.1 Routine Inspection and Maintenance

Pump requires very little maintenance. However, pump and all accessories should be checked weekly. This is especially important when pumping chemicals. Inspect all components for signs of leaking, swelling, cracking, discoloration or corrosion. Replace worn or damaged components immediately.

Cracking, crazing, discoloration during first week of operation are signs of severe chemical attack. If this occurs, immediately remove chemical from pump. Determine which parts are being attacked and replace them with parts that have been manufactured using more suitable materials. Manufacturer does not assume responsibility for damage to pump that has been caused by chemical attack.

11.2 Cleaning Pump

Pump will require occasional cleaning, especially Injection fitting, footvalve / strainer, and pump head valves. Frequency will depend on type and severity of service.

- Inspect and replace pump head valves as required.
- Periodically clean injection / check valve assembly, especially when injecting fluids that calcify such as sodium hypochlorite. These deposits and other build ups can clog fitting, increase back pressure and interfere with check valve operation.
- Periodically clean suction strainer.
- Periodically inspect pump housing (enclosure) for chemical attack. Protect pump housing from continuous exposure to chemicals, such as drips or fumes from surrounding equipment and plumbing.

11.3 Replacing the Pump Diaphragm

- When changing the diaphragm, the pump head chamber and pump head cover should be wiped free of any dirt and debris. The pump stroke must be FORWARD when installing the diaphragm (hand tighten), and BACK when installing and tightening the pump head. Tighten screws on pump head evenly and incrementally. Final tightening to be done with a torque rating at 20 in-lbs. **Once the pump has been fully reassembled, allow the pump to run for 24 hours then go back and re-torque the screws to 20 in-lbs.**
- When replacing the pump diaphragm, note the order of parts per the illustration below:

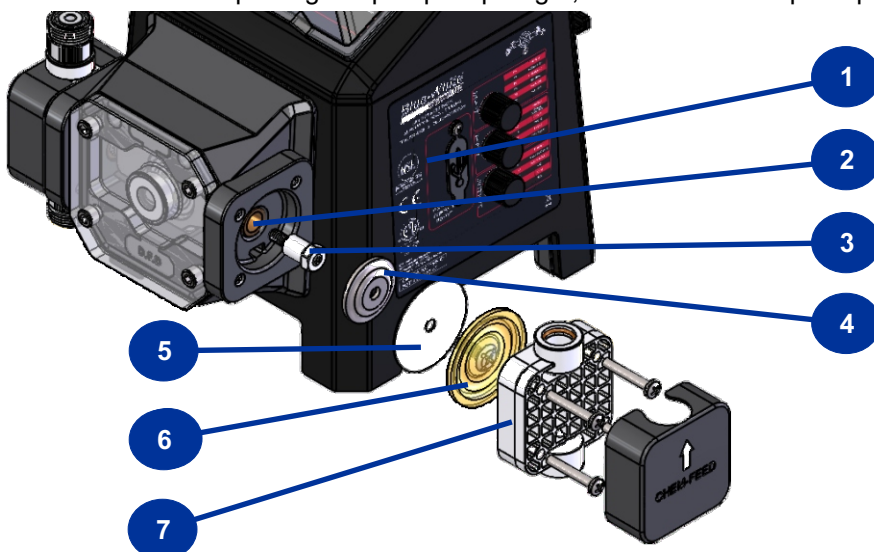

Item	Item
1	Pump
2	Piston
3	Diaphragm Standoff
4	Backup Washer
5	PTFE Ring
6	Diaphragm
7	Pump Head

12.0 Updating The Firmware

REQUIREMENTS: Download & Install the CD1 Programmer file by visiting the Firmware Update section of the CD1 product page at www.blue-white.com as well as download the Firmware Update File.

1. Connect the Pump to a computer via USB-A / USB-C cable
(Pump must not be powered before starting.) **(Be sure to replace USB cover after updating firmware)**
2. Power up the Pump
3. Open the CD1 programmer
4. Select “Enable” USB in the Communication settings window [Watch this Video for further assistance.](#)
5. Click on Connect

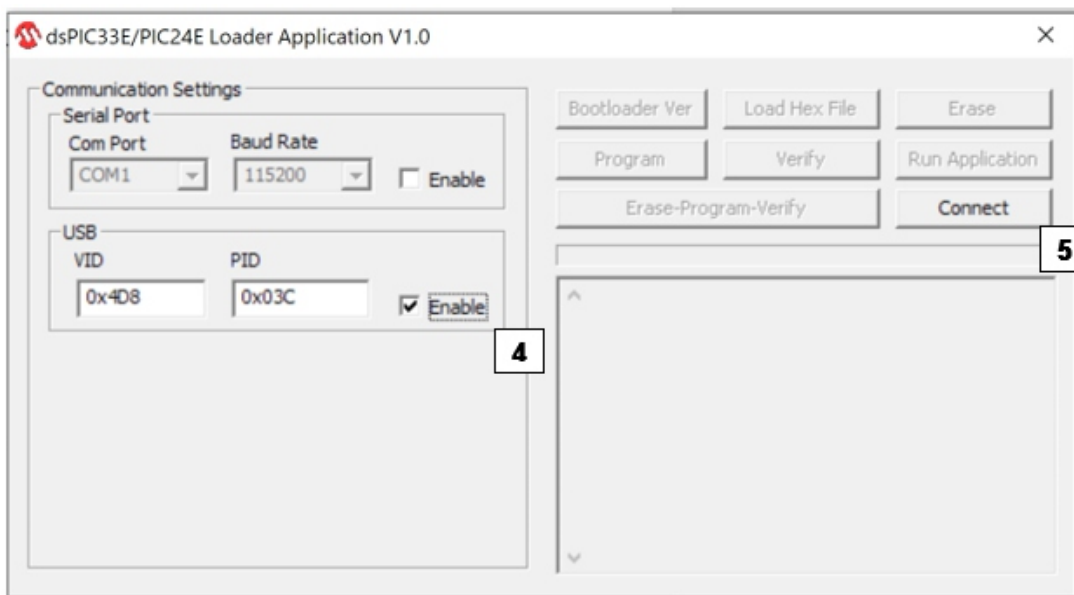

6. Select “Load Hex File”

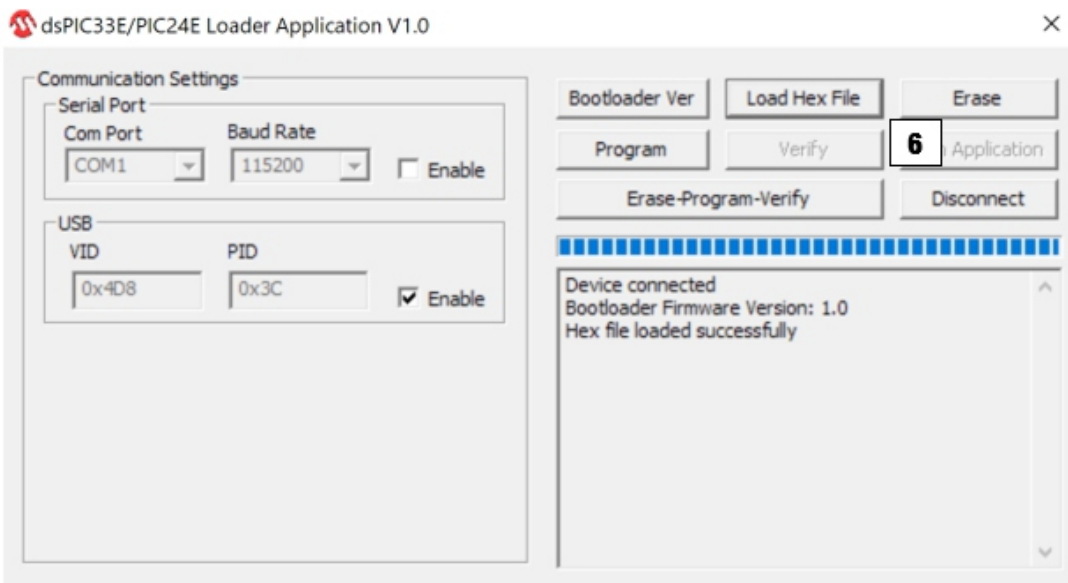

7. Select “.HEX” file (See Blue-White website for latest version)



CD1x_xxx.hex

8. Click on “Erase-Program-Verify”

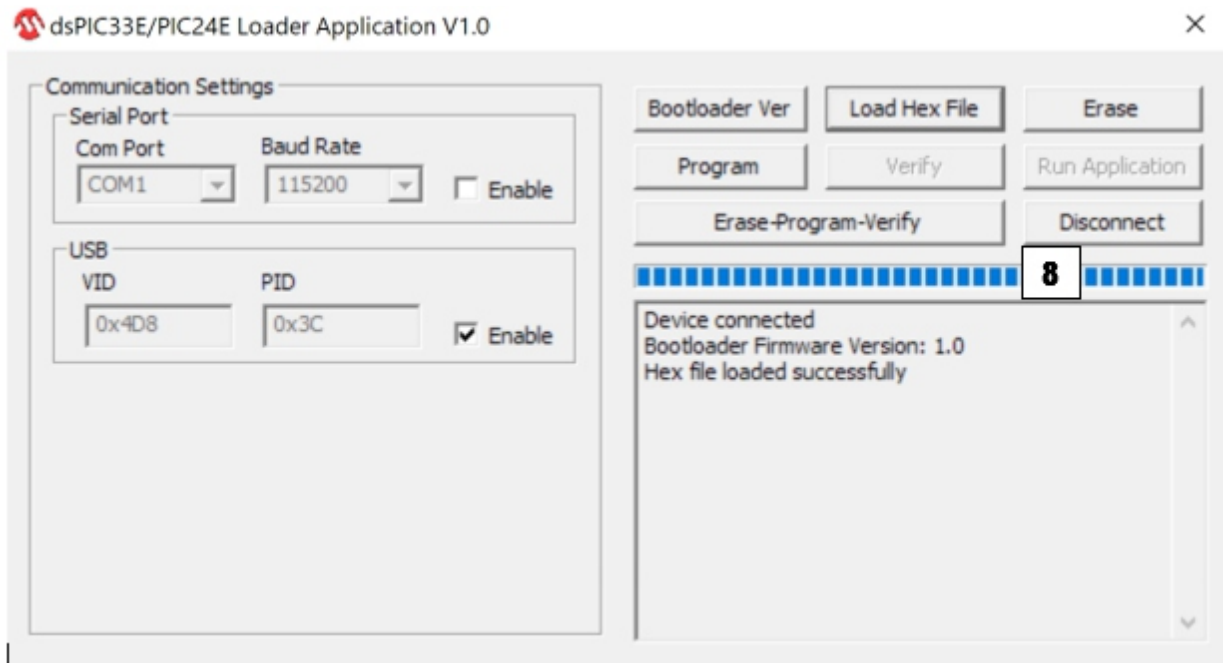

9. Once Hex file is loaded successfully
10. Click on “Disconnect”. Your firmware has now been updated.

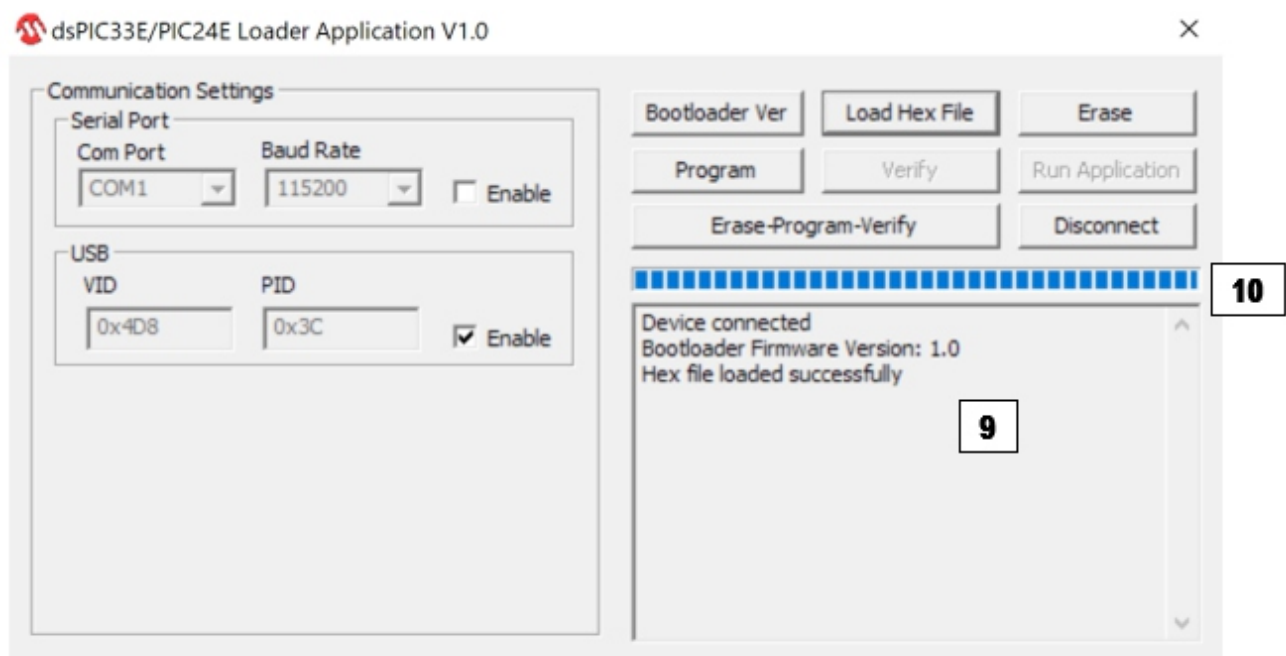

13.0 REPLACEMENT PARTS LIST

Item	Part No.	Product Name	Qty. Req.
1	90011-150	Screw 10-32 x .50 SOC Cap SS	4
3	90006-600	Back-Up Washer HD .100" Thick	2
4	71010-730	Manifold, PVDF	2
5	90002-707	Adapter Cart	4
6	70004-539	P/Head Cover CHEM-FEED®	2
7		Adapters	2 ----->
8	90002-712	Nut, Union, PVDF	2
10	90018-087	Standoff Threaded	2
11	71010-837	Cover, Front	1

ELBOW & STRAIGHT ADAPTER KITS

Kits include:

- (2) #7 adapters
- (2) #8 Union Nuts
- (2) #14 O-rings



Item	Part No.	Product Name	Qty. Req.
12	71010-926	Cartridge Bullet, PVDF, Aflas O-rings	6
	71010-928	Cartridge Bullet, PVDF, EP O-rings	6
13	71010-944	Cartridge Bullet De-Gas, PVDF, Aflas	1
	71010-945	Cartridge Bullet De-Gas, PVDF, EP	1
14	90003-581	O-Ring, Aflas	6
	90003-633	O-Ring, EP	6
15	90003-014	O-Ring, Aflas	4
	90003-600	O-Ring, EP	4
16	KIT-CDV**	Kit, Diaphragm DiaFlex®	1
	KIT-CDE**	Kit, Diaphragm Flex-A-Prene®	1
17	70004-096	Pump/HD HDN LG PVDF V Stamp	2
	70004-097	Pump/HD HDN LG PVDF E Stamp	2
21	90011-141	Screw 10-32 X 1.25 Pan Phil SS	8
N/S	C-330-6	Tube Nut, 1/4" x 3/8"	2
N/S	KIT-DVA1*	Cart. Valve Kit, De-Gas, Aflas	1
	KIT-DVE1*	Cart. Valve Kit, De-Gas, EP	1
	KIT-DKA1*	Cart. Valve Kit, De-Gas w/ standoffs, Aflas	1
	KIT-DKE1*	Cart. Valve Kit, De-Gas w/ standoffs, EP	1

* Includes Qty 6 Cart. Bullet and Qty 1 De-Gas Cart.

** Includes Qty 2 Diaphragms and Qty 2 Backing pieces

- KIT-CA1SE Elbow Adapter Kit, 1/4" x 3/8" tubing comp., Aflas O-rings
- KIT-CE1SE Elbow Adapter Kit, 1/4" x 3/8" tubing comp., EP O-rings
- KIT-CA1ME Elbow Adapter Kit, 1/2" M/NPT fitting, Aflas O-rings
- KIT-CE1ME Elbow Adapter Kit, 1/2" M/NPT fitting, EP O-rings
- KIT-CA1BE Elbow Adapter Kit, 1/2" Hose Barb, Aflas O-rings
- KIT-CE1BE Elbow Adapter Kit, 1/2" Hose Barb, EP O-rings
- KIT-CA1S Straight Adapter Kit, 1/4" x 3/8" tubing comp., Aflas O-rings
- KIT-CE1S Straight Adapter Kit, 1/4" x 3/8" tubing comp., EP O-rings
- KIT-CA1M Straight Adapter Kit, 1/2" M/NPT fitting, Aflas O-rings
- KIT-CE1M Straight Adapter Kit, 1/2" M/NPT fitting, EP O-rings
- KIT-CA1B Straight Adapter Kit, 1/2" Hose Barb, Aflas O-rings
- KIT-CE1B Straight Adapter Kit, 1/2" Hose Barb, EP O-rings

13.1 EXPLODED VIEW

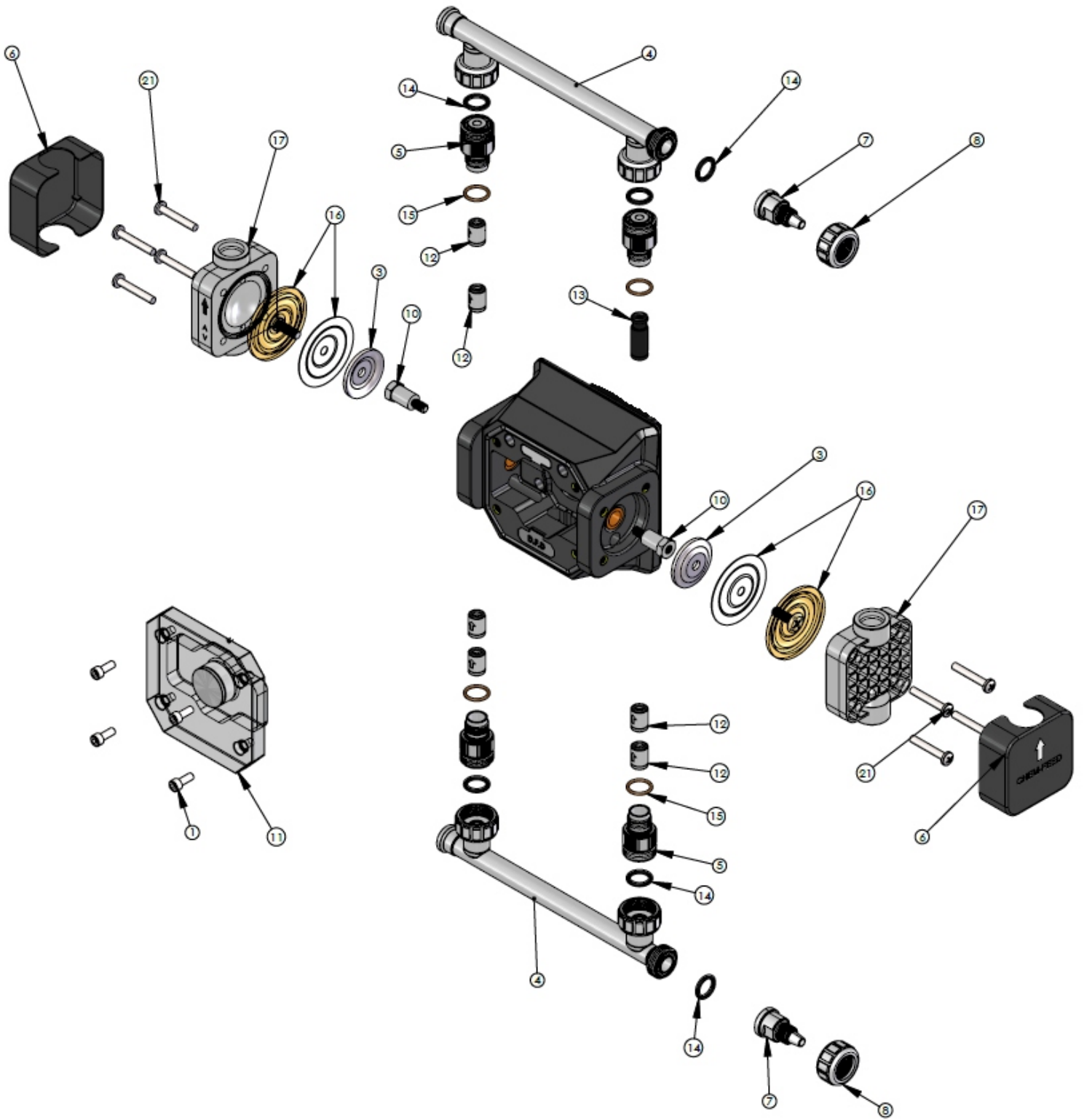

14.0 ACCESSORIES

NOTE: All Accessories are sold separately



KIT-M12
TWO M12 CABLES

KIT-M12

Kit contains: Two M12 cables. 10 foot length.
Other cable lengths:
KIT-M12-2-15 15 foot length.
KIT-M12-2-30 30 foot length.

KIT-M12 WIRING INSTRUCTIONS		
DIAGRAM	PIN #	WIRE COLOR
	PIN 1	BROWN
	PIN 2	WHITE
	PIN 3	BLUE
	PIN 4	BLACK
	PIN 5	GRAY

NOTE: THIS DIAGRAM IS FOR THE PUMP'S M12 PORT



KIT-M12-3
THREE M12 CABLES

KIT-M12-3

Kit contains: Three M12 cables. 10 foot length.
Other cable lengths:
KIT-M12-3-15 15 foot length.
KIT-M12-3-30 30 foot length.



CABLE-UAC
USB A-C CABLE

CABLE-UAC

Kit contains: One 3' USB-A to USB-C cable.

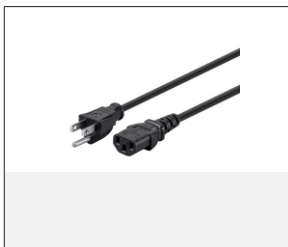

POWER CORDS - DETACHABLE

- 90010-663 115V/60Hz NEMA 5/15
- 90010-664 220V/50Hz CEE 7/V11
- 90010-665 230V/50Hz BS 1363/A
- 90010-666 240V/50Hz AS 3112
- 90010-696 230V/60Hz NEMA 6/15
- 90010-821 115V/60Hz NEMA 5/15 (Lockable)



KIT-CQA / KIT-CQE
QUICK CONNECT CD1 /MD1

KIT-CQA (Aflas O-rings) / KIT-CQE (EP O-rings)

Kit contains: One discharge fitting with o-rings installed (red), One suction fitting with o-rings installed (white), Two tube nuts, Two 1/2" hose barb quick connect adapters, Two 1/2" M/NPT quick connect adapters, Two quick disconnect adapters and Two #5 hose clamps.



KIT-C5M
CD1 1/2" MNPT Adapter Fittings

KIT-C5M

Kit contains: Two 1/2" MNPT adapters with integral Union nuts.



KIT-C5B
CD 1/2" HOSE BARB

KIT-C5B

Kit contains: Two union nuts, Two 1/2" hose barb adapters, Two #5 hose clamps, One 2 1/2' clear reinforced PVC tube and One 5' 5/8" suction tube



Elbow Adapter Kits

ELBOW ADAPTER KITS (Kits include (2) adapters, (2) Union Nuts, (2) O-rings)

KIT-CA1SE	Elbow Adapter Kit, 1/4" x 3/8" tubing connection, Aflas O-rings
KIT-CE1SE	Elbow Adapter Kit, 1/4" x 3/8" tubing connection, EP O-rings
KIT-CA1ME	Elbow Adapter Kit, 1/2" M/NPT connection, Aflas O-rings
KIT-CE1ME	Elbow Adapter Kit, 1/2" M/NPT connection, EP O-rings
KIT-CA1BE	Elbow Adapter Kit, 1/2" Hose Barb connection, Aflas O-rings
KIT-CE1BE	Elbow Adapter Kit, 1/2" Hose Barb connection, EP O-rings

Suction / Discharge Tubing
1/4" ID x 3/8" OD

SUCTION AND DISCHARGE TUBING

C-334-6	Tubing, Suction, clear PVC 3/8" O.D. x 5' length
C-334-6-10	Tubing, Suction, clear PVC 3/8" O.D. x 10' length
C-334-6-100	Tubing, Suction, clear PVC 3/8" O.D. x 100' length
C-335-6	Tubing, Discharge, opaque PE 3/8" O.D. x 5' length
C-335-6-10	Tubing, Discharge, opaque PE 3/8" O.D. x 10' length
C-335-6-100	Tubing, Discharge, opaque PE 3/8" O.D. x 100' length

KIT-S07
STAR III 7 GALLON TANK

KIT-S07

Kit contains: One 7 gallon tank, One foot valve and strainer and One mounting bracket with screws

KIT-S15
STAR III 15 GALLON TANK

KIT-S15

Kit contains: One 15 gallon tank, One foot valve and strainer and One mounting bracket with screws

KIT-S30
STAR III 30 GALLON TANK

KIT-S30

Kit contains: One 30 gallon tank, One foot valve and strainer and One mounting bracket with screws

KIT-PSM
WALL MOUNT BRACKET, HDPE

KIT-PSM

Kit contains: One HDPE Bracket, (4) 3/8" x 2-3/4" long dia anchor bolts.

13.0 TROUBLESHOOTING

Error Code	Explanation	Troubleshooting
E01	Motor Over Current	Ensure that diaphragm is installed properly
E02	Over Voltage	Check power supply output voltage
E03	Under Voltage	Check power supply output voltage
E04	Temperature exceeds 75°C at control	Check ambient conditions, restart pump once cooled to ambient temperature
E05	Inverter Error	Contact Blue-White Industries (714) 893-8529 customerservice@blue-white.com
E06	No Motor Connection	Contact Blue-White Industries (714) 893-8529 customerservice@blue-white.com
E08	Motor Stall	Ensure that diaphragm is installed properly
E10	Capacitor bank charging error	Contact Blue-White Industries (714) 893-8529 customerservice@blue-white.com
E17	Communication error at display	Contact Blue-White Industries (714) 893-8529 customerservice@blue-white.com

14.0 WARRANTY

14.1 Limited Warranty

Your Blue-White product is a quality product and is warranted for a specific time from date of purchase (proof of purchase is required). The product will be repaired or replaced at our discretion. Failure must have occurred due to defect in material or workmanship and not as a result of operation of the product other than in normal operation as defined in the product manual. Warranty status is determined by the product's serial label and the sales invoice or receipt. The serial label must be on the product and legible. The warranty status of the product will be verified by Blue-White or a factory authorized service center.

CHEM-FEED® CD1 pumps are warranted for 2 years from date of purchase (proof of purchase is required). Pumps will be repaired or replaced at our discretion.

14.2 DiaFlex® Warranty

DiaFlex® diaphragms are warranted for the life of the pump. Blue-White will replace a damaged diaphragm at no cost to the customer provided the pump was at all times operated within the guidelines included in the pump's operation manual. This warranty only applies to DiaFlex® diaphragms, not the pumps themselves. Blue-White pumps are separately covered by warranties specific to them.

14.3 What is not Covered

- > **Flex-A-Prene® diaphragm and rubber components - They are perishable and require periodic replacement**
- > **Pump removal, or re-installation, and any related labor charge.**
- > **Freight to the factory, or service center**
- > **Pumps that have been tampered with, or in pieces.**
- > **Damage to the pump that results from misuse, carelessness (such as chemical spills on the enclosure), abuse, lack of maintenance, or alteration that is out of Blue-White control.**
- > **Pumps damaged by faulty wiring, power surges, or acts of nature.**

Blue-White does not assume responsibility for any loss, damage, or expense directly or indirectly related to or arising out of the use of its products. Failure must have occurred due to defect in material or workmanship and not as a result of operation of the product other than in normal operation as defined in the pump operation manual.

The warranty status is determined by the pump's serial label and the sales invoice or receipt. The serial label must be on the pump and be legible. The warranty status of the pump will be verified by Blue-White or a factory authorized service center.

14.4 Procedure for In-Warranty Repair

Warranty service must be performed by the factory or an authorized service center. Contact the factory or local repair center to obtain a RMA (Return Material Authorization) number. It is recommended to include foot strainer and injection/check valve fitting since these devices may be clogged and part of the problem. Decontaminate, dry, and carefully pack the product to be repaired. Please enclose a brief description of the problem and proof of purchase. Prepay all shipping and insurance cost. COD shipments will not be accepted. Damage caused by improper packaging is the responsibility of the sender. When In-Warranty repair is completed, the factory pays for return shipping to the dealer or customer.

14.5 Product Use Warning

Blue-White products are manufactured to meet the highest quality standards in the industry. Each product instruction manual includes a description of the associated product warranty and provides the user with important safety information. Purchasers, installers, and operators of Blue-White products should take the time to inform themselves about the safe operation of these products. In addition, Customers are expected to do their own due diligence regarding which products and materials are best suited for their intended applications. Blue-White is pleased to assist in this effort but does not guarantee the suitability of any particular product for any specific application as Blue-White does not have the same degree of familiarity with the application that the customer/end user has. While Blue-White will honor all of its product warranties according to their terms and conditions, Blue-White shall only be obligated to repair or replace its defective parts or products in accordance with the associated product warranties. **BLUE-WHITE SHALL NOT BE LIABLE EITHER IN TORT OR IN CONTRACT FOR ANY LOSS OR DAMAGE WHETHER DIRECT, INDIRECT, INCIDENTAL, OR CONSEQUENTIAL, ARISING OUT OF OR RELATED TO THE FAILURE OF ANY OF ITS PARTS OR PRODUCTS OR OF THEIR UNSUITABILITY FOR A GIVEN PURPOSE OR APPLICATION.**

14.6 Chemical Resistance Warning

Blue-White offers a wide variety of wetted parts. Purchasers, installers, and operators of Blue-White products must be well informed and aware of the precautions to be taken when injecting or measuring various chemicals, especially those considered to be irritants, contaminants or hazardous. Customers are expected to do their own due diligence regarding which products and materials are best suited for their applications, particularly as it may relate to the potential effects of certain chemicals on Blue-White products and the potential for adverse chemical interactions.

Blue-White tests its products with water only. The chemical resistance information included in this instruction manual was supplied to Blue-White by reputable sources, but Blue-White is not able to vouch for the accuracy or completeness thereof. While Blue-White will honor all of its product warranties according to their terms and conditions, Blue-White shall only be obligated to repair or replace its defective parts or products in accordance with the associated product warranties.

BLUE-WHITE SHALL NOT BE LIABLE EITHER IN TORT OR IN CONTRACT FOR ANY LOSS OR DAMAGE, WHETHER DIRECT, INDIRECT, INCIDENTAL, OR CONSEQUENTIAL, ARISING OUT OF OR RELATED TO THE USE OF CHEMICALS IN CONNECTION WITH ANY BLUE-WHITE PRODUCTS.

ACRONYMS

°C	Celsius	min	Minute
°F	Fahrenheit	mL	Milliliters
AC	Alternating current	MSDS	Material Safety Data Sheet
bar	Unit of pressure	N.C.	Normally Close
CIP	Clean-in-place	N.O.	Normally Open
cm	Centimeters	NPT	National Pipe Thread
COD	Cash on Delivery	NSF	National Sanitation Foundation
D	Depth	OD	Outside diameter
DC	Direct current	P.N.	Part Number
EEE	Electrical and electronic equipment	PBT	Polybutylene Terephthalate
EP	Ethylene propylene	PE	Polyethylene
ETL	Electrical Testing Labs/Intertek	PSI	Pounds per Square Inch
EU	European Union	PVC	Polyvinyl chloride
FDA	Food and Drug Administration	PVDF	Polyvinylidene fluoride
FKM	Fluoroelastomer	RCD	Residual-current device
FVS	Flow Verification Sensor	Rev.	Revision
GF	Glass fiber	RMA	Return Material Authorization
GPD	Gallons per day	RPM	Revolutions per minute
GPH	Gallons per hour	SIP	Steam-in-place
H	Height	SS	Solid state
Hz	Hertz	TFD	Tube Failure Detection
ID	Inside diameter	TFE/P	Tetrafluoroethylene propylene
IO	Input/Output	UL	Underwriters Laboratories
Kg	Kilogram	US	United States
lb.	Pound	V	Volt
LLDPE	Linear low-density polyethylene	W	Watt
LPH	Liters per hour	W	Width
mA	Milliampere	WEEE	Waste Electrical and Electronic Equipment

CHEM-FEED® Model Number

CD1	CHEM-FEED® Diaphragm Metering Pump				
Control					
F	Standard Control Methods (Manual, Remote, FVS)				
V	4-20mA Input, 4-20mA Output, in addition to Standard Control Methods (Manual, Remote, FVS)				
Diaphragm and O-Rings Material					
V	DiaFlex® Diaphragms and TFE/P O-Rings (For all chemicals excluding caustic soda and aqueous ammonia)				
E	Flex-A-Prene® Diaphragms and EP O-Rings (For caustic soda and aqueous ammonia)				
Pump Fittings (Inlet / Outlet)					
B	1/2" ID Barb Straight Fittings				
C	1/2" ID Barb Elbow Fittings				
S	1/4" x 3/8" Compression Straight Fittings				
T	1/4" x 3/8" Compression Elbow Fittings				
M	1/2" M/NPT Straight Fittings				
X	1/2" M/NPT Elbow Fittings				
Power Cord - Removable (Operating voltage requirement 96VAC to 264VAC)					
4	115V 50/60Hz, power cord NEMA 5/15 plug (US)				
6	220V 50/60Hz, power cord CEE 7/V11 plug (EU)				
X	No Power Cord Provided (Power cord is required - See accessories for power cord options)				
CD1	F	V	B	4	Sample Model Number

NOTES

NOTES

Blue-White[®]

Fluid metering solutions made simple



Users of electrical and electronic equipment (EEE) with the WEEE marking per Annex IV of the WEEE Directive must not dispose of end of life EEE as unsorted municipal waste, but use the collection framework available to them for the return, recycle, recovery of WEEE and minimize any potential effects of EEE on the environment and human health due to the presence of hazardous substances. The WEEE marking applies only to countries within the European Union (EU) and Norway. Appliances are labeled in accordance with European Directive 2002/96/EC.

Contact your local waste recovery agency for a *Designated Collection Facility* in your area.

5300 Business Drive
Huntington Beach, CA 92649
USA

TEL: 714-893-8529
FAX: 714-894-9492

www.blue-white.com
sales@blue-white.com
customerservice@blue-white.com