

FR45 SERIES

INDUSTRIAL HOSE PUMPS

Designed to meet the demanding requirements of chemical injection, dispensing and transfer applications

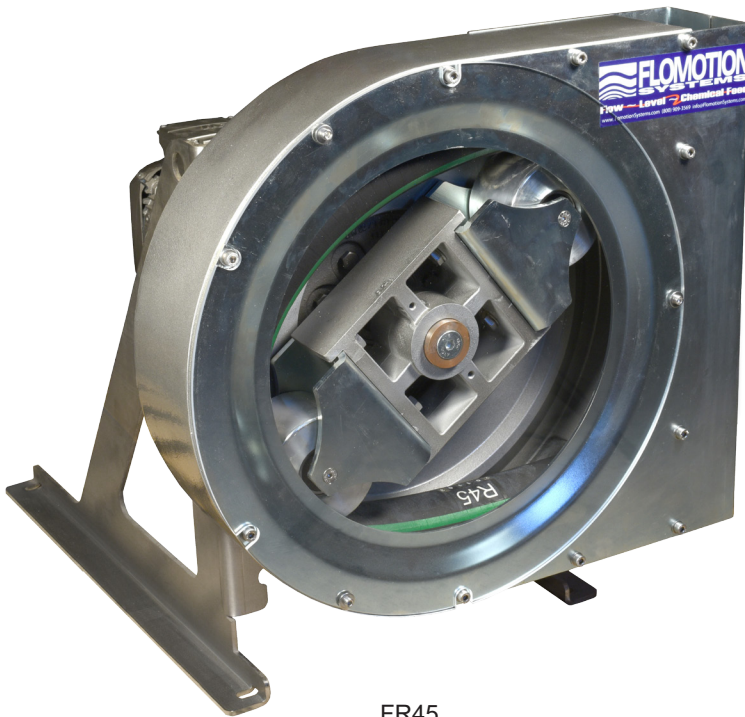

FR45

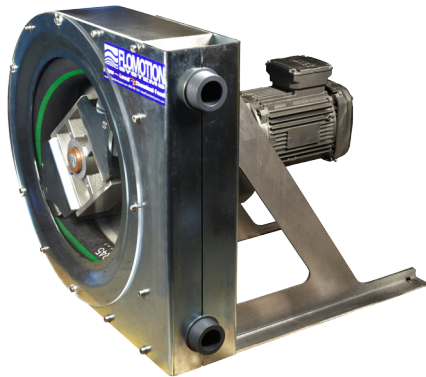

The FR45 is a two roller peristaltic pump designed to handle abrasive slurries, viscous fluids, and aggressive chemicals that are normally difficult to pump with other types of positive displacement technologies. The FR45 is an ideal choice for metering, batching and transfer applications. Peristaltic pumps are becoming the standard for hard to handle fluids such as Sodium Hypochlorite that off-gas and vapor-lock diaphragm pumps.

Three models are available that offer a wide range of flow rate outputs. Newer hose materials offer better chemical resistance and longer life in demanding applications.

SAFETY FIRST

An optional tubing rupture detector will automatically shut down the pump and signal an alarm in the event of a tubing leak. The Tubing Rupture Detector helps to protect operators and other equipment from potentially dangerous fumes and chemicals.



FR45 FEATURES

- Flows to 2319 GPH, Pressures to 60 psi.
- Viscosities to 15,000 cps.
- Seal-less pumping technology.
- Self-priming suction lifts to 20ft vertical.
- Non-lubricant filled roller design.
- Hose barb, NPT and flanged process connections.
- No check valves - few moving parts.
- Dry running without damage.

PERISTALTIC PUMPS

FLOMOTION FR45 SERIES ENGINEERING SPECIFICATIONS

FR SERIES PUMP SPECIFICATIONS

	FR13	FR17	FR17E	FR25	FR30	FR45
	GPH (GPM)	GPH (GPM)	GPH (GPM)	GPH (GPM)	GPH (GPM)	GPH (GPM)
Flow Rate (max)	52.9 (0.9)	138 (1.9)	138 (1.9)	390 (6.5)	777 (13)	2319 (38)
Discharge Pressure (psi)*	60	60	60	60	60	60
Suction Lift (ft)	20	20	20	20	20	20
Weight (lbs)	30	40	40	47	172	275

* Pressure rating dependent on tubing material.

Installed Power (hp)
2.0 hp

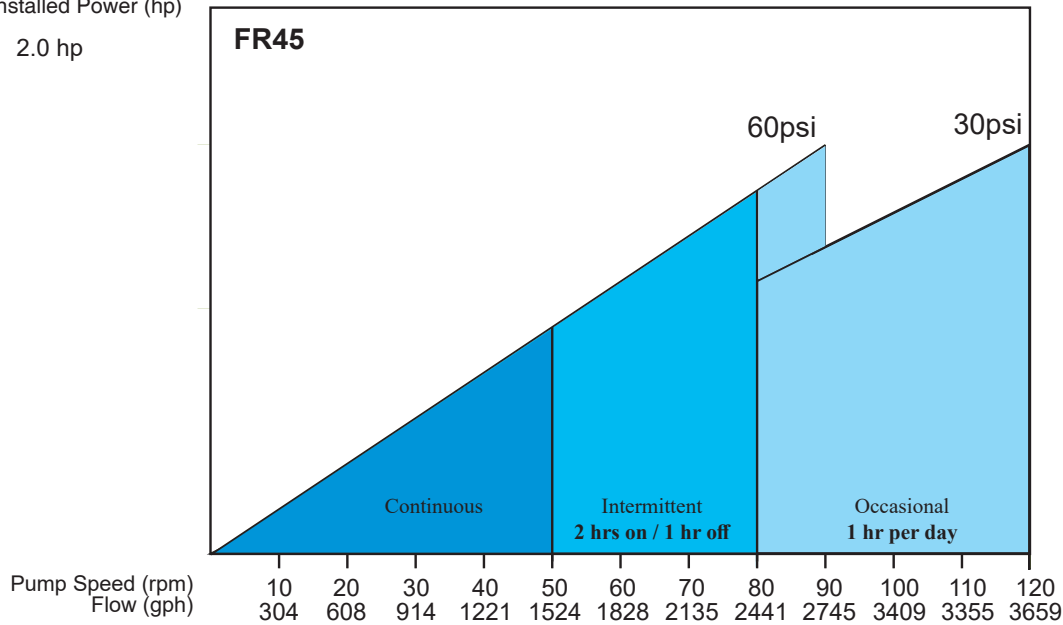

FR45 SPECIFICATIONS AND DIMENSIONS

in [mm]

GEARMOTOR

2.0HP, 230 VAC, 3-PH, TEFC, INVERTER DUTY WITH CORROSION RESISTANT EPOXY COATED FINISH

PUMPHEAD

ALUMINUM WITH CORROSION RESISTANT INDUSTRIAL DUTY PAINT AND ELECTROPLATED STEEL COVER WITH PLEXIGLASS WINDOW

ROLLER ASSEMBLY

ADJUSTABLE ALUMINUM/ELECTROPLATED STEEL WITH ALUMINUM ROLLERS AND SEALED BEARINGS

PROCESS CONNECTIONS

2" MNPT - PVC, PTFE, 316 SS

HOSE MATERIAL

NATURAL RUBBER
EPDM
BUNA-N
HYPALON
VITON

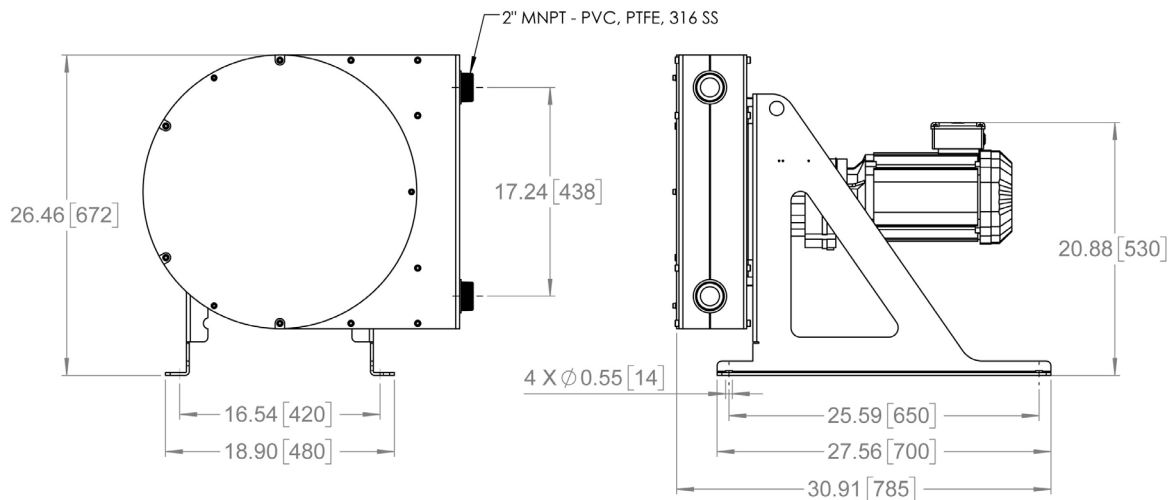

FLOMOTION SYSTEMS Inc.

3 North Main St.
Middleport, NY 14105
Tel: 716-691-3941

Email: info@flomotionsystems.com
www.flomotionsystems.com

