

FS15 Series

INDUSTRIAL HOSE PUMPS

Designed to meet the demanding requirements of chemical injection, dispensing and transfer applications.

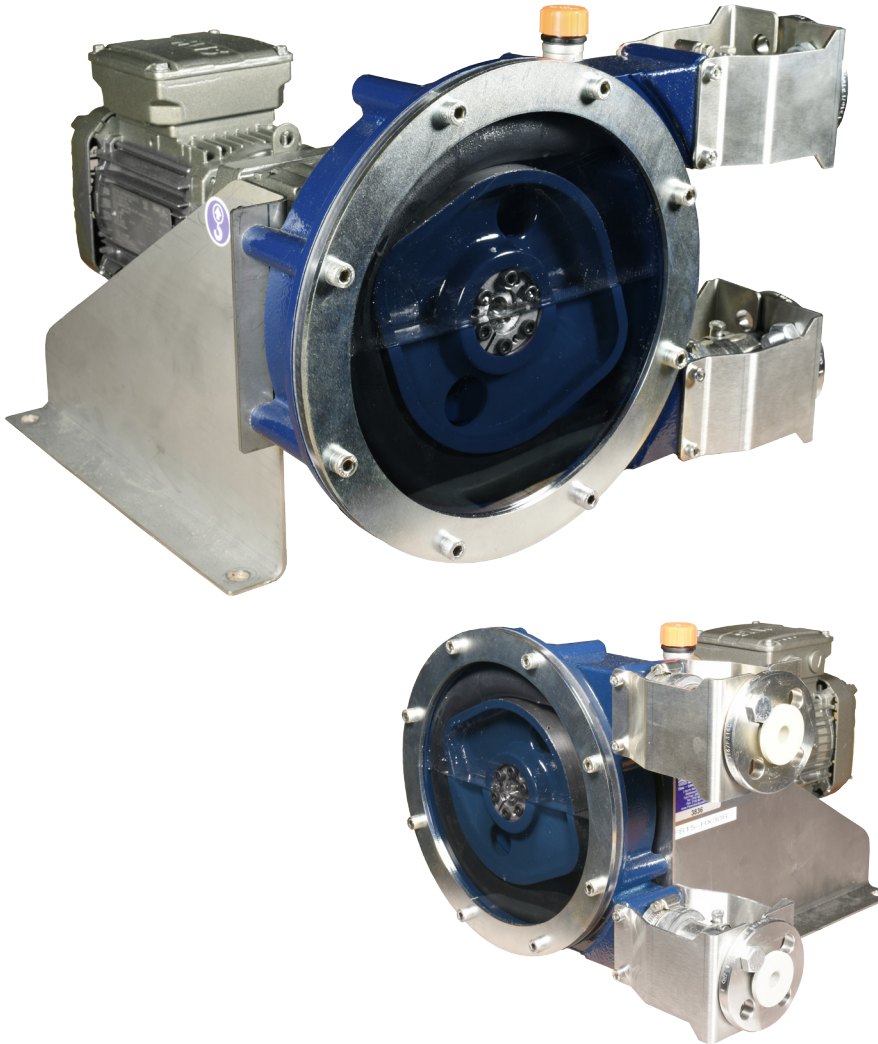

The FS15 Series peristaltic pump is a lobe design on a rotating wheel successively compressing a reinforced rubber hose. The motion of the lobes compresses the rubber against the pump housing creating continuous suction at the inlet of the pump and pushing the fluid to the outlet of the pump.

The sealed pump casing contains a lubricant that reduces friction of the shoes moving over the rubber hose. The pumped fluid is in contact only with the interior of the rubber hose, thus permitting the pumping of a wide variety of reactive fluids.

PERISTALTIC HOSE PUMPS

SAFETY FIRST - Sealed Pumphead Design - Hose Rupture Detector

An optional hose rupture detector will automatically shut down the pump and signal an alarm in the event of a hose leak.

Together, the unique sealed pump design and the Hose Rupture Detector help to protect operators and other equipment from potentially dangerous fumes and chemicals.



FS15 FEATURES

- Flows to 132 GPH, Pressures to 110 psi.
- Viscosities to 100,000 cps
- Seal-less pumping technology
- Self-priming suction lifts to 30ft vertical
- Glycerine filled pumphead for extended hose life
- Flanged connections with PP, PVDF or 316SS Inserts
- No check valves - few moving parts
- Dry running without damage

FLOMOTION FS15 SERIES ENGINEERING SPECIFICATIONS

FLOMOTION FS15 SERIES PUMP PERFORMANCE

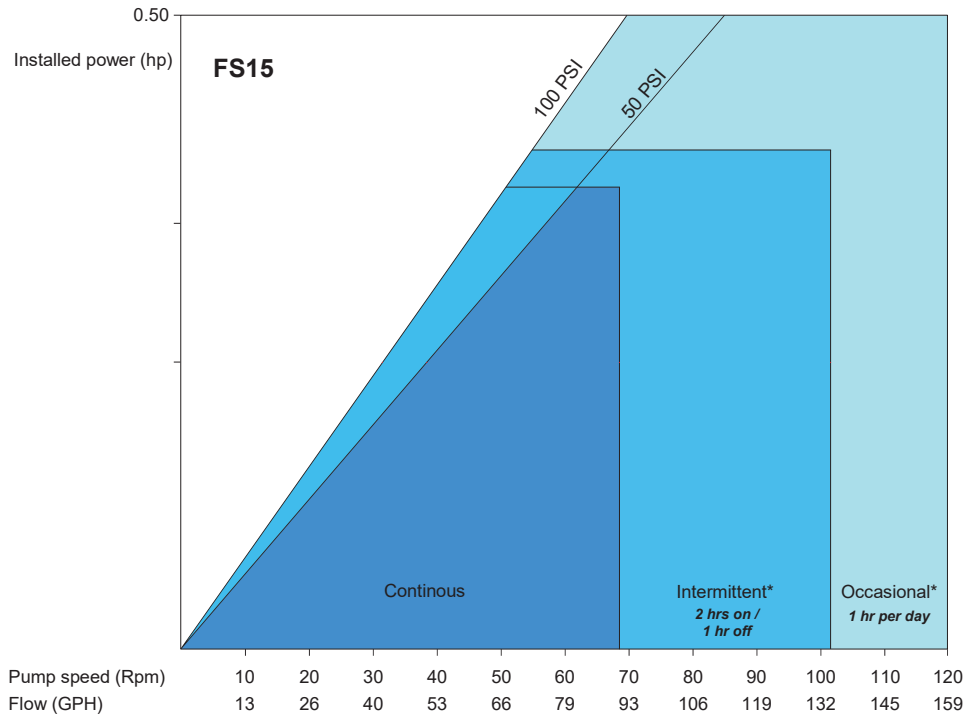

FS15 SPECIFICATIONS AND DIMENSIONS

in [mm]

GEARMOTOR

1/2HP, 230 VAC, 3-PH, TEFC,
INVERTER DUTY WITH
CORROSION RESISTANT
EPOXY COATED FINISH

PUMPHEAD

DUCTILE IRON AND PAINTED
WITH INDUSTRIAL GRADE
CORROSION RESISTANT PAINT

PUMP ROTOR

ASTM CLASS 45B CAST IRON
WITH TWO INTEGRALLY CAST
LOBES LOCATED 180° APART

PROCESS CONNECTIONS

1/2" ANSI 150# FLANGES
316 STAINLESS STEEL

PROCESS CONNECTION INSERTS

POLYPROPYLENE
PTFE
316 STAINLESS STEEL

HOSE MATERIAL

NATURAL RUBBER
EPDM
BUNA-N
HYPALON
VITON

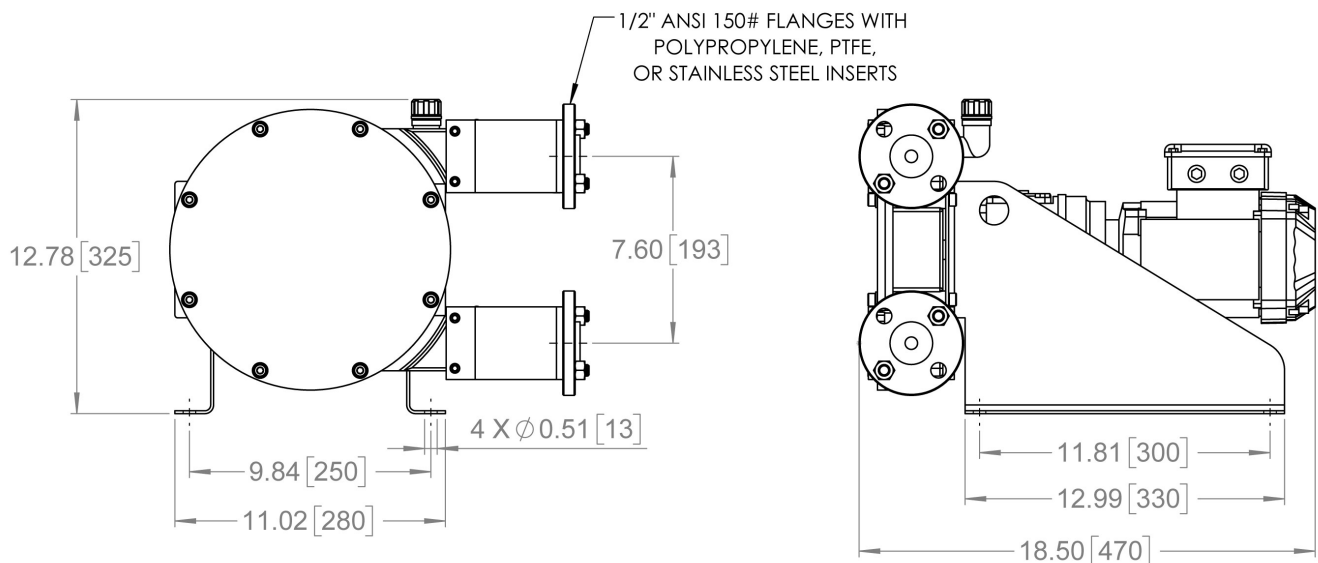

FLOMOTION SYSTEMS Inc.

3 North Main St.

Middleport, NY 14105

Tel: 716-691-3941

Email: info@flomotionsystems.com

www.flomotionsystems.com

