

FS32 Series

INDUSTRIAL HOSE PUMPS

Designed to meet the demanding requirements of chemical injection, dispensing and transfer applications.



The FS32 Series peristaltic pump is a two-shoe design, 180° apart on a rotating wheel, successively compressing a reinforced rubber hose. The motion of the shoes compresses the rubber against the pump housing creating continuous suction at the inlet of the pump and pushing the fluid to the outlet of the pump.

The sealed pump casing contains a lubricant that reduces friction of the shoes moving over the rubber hose. The pumped fluid is in contact only with the interior of the rubber hose, thus permitting the pumping of a wide variety of reactive fluids.

PERISTALTIC HOSE PUMPS

SAFETY FIRST - Sealed Pumphead Design - Hose Rupture Detector

An optional hose rupture detector will automatically shut down the pump and signal an alarm in the event of a hose leak.

Together, the unique sealed pump design and the Hose Rupture Detector help to protect operators and other equipment from potentially dangerous fumes and chemicals.



FS32 FEATURES

- Flows to 23 GPM, Pressures to 218 psi.
- Viscosities to 100,000 cps
- Seal-less pumping technology
- Self-priming suction lifts to 30ft vertical
- Glycerine filled pumphead for extended hose life
- Flanged connections with PP, PVDF or 316SS Inserts
- No check valves - few moving parts
- Dry running without damage

FLOMOTION FS32 SERIES ENGINEERING SPECIFICATIONS

FLOMOTION FS32 SERIES PUMP PERFORMANCE

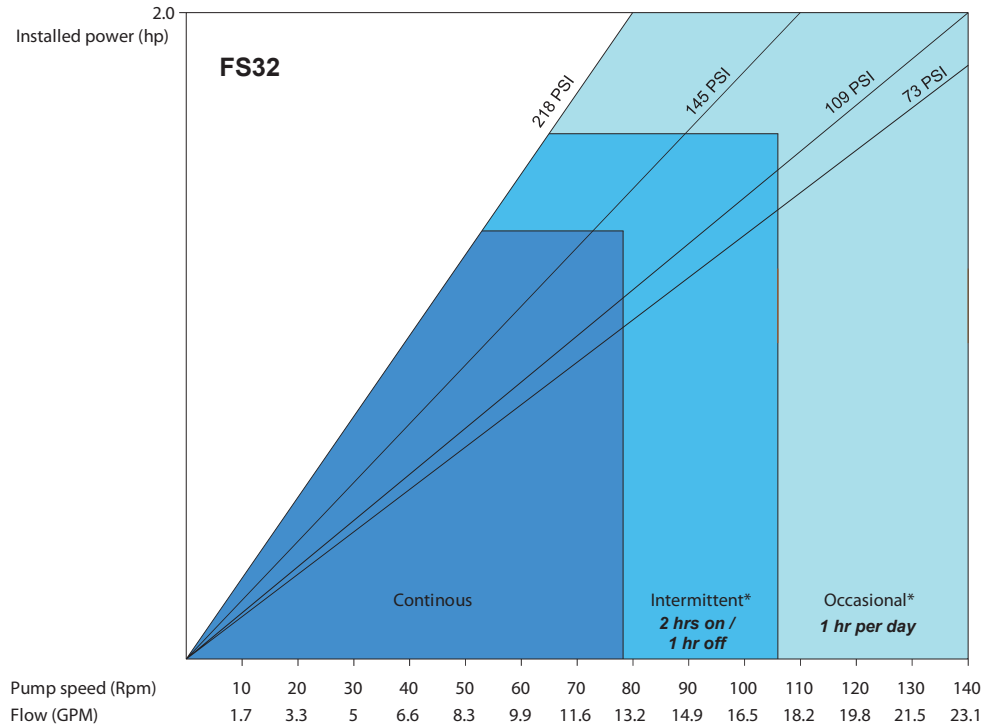

FS32 SPECIFICATIONS AND DIMENSIONS

in [mm]

GEARMOTOR

2HP, 230 VAC, 3-PH, TEFC, INVERTER DUTY WITH CORROSION RESISTANT EPOXY COATED FINISH

PUMPHEAD

DUCTILE IRON AND PAINTED WITH INDUSTRIAL GRADE CORROSION RESISTANT PAINT

PUMP ROTOR

ASTM CLASS 45B CAST IRON WITH TWO INTEGRALLY MOUNTED SHOES WITH SHIMS LOCATED 180° APART

PROCESS CONNECTIONS

1 1/2" ANSI 150# FLANGES 316 STAINLESS STEEL

PROCESS CONNECTION INSERTS

POLYPROPYLENE PTFE 316 STAINLESS STEEL

HOSE MATERIAL

NATURAL RUBBER EPDM BUNA-N HYPALON VITON

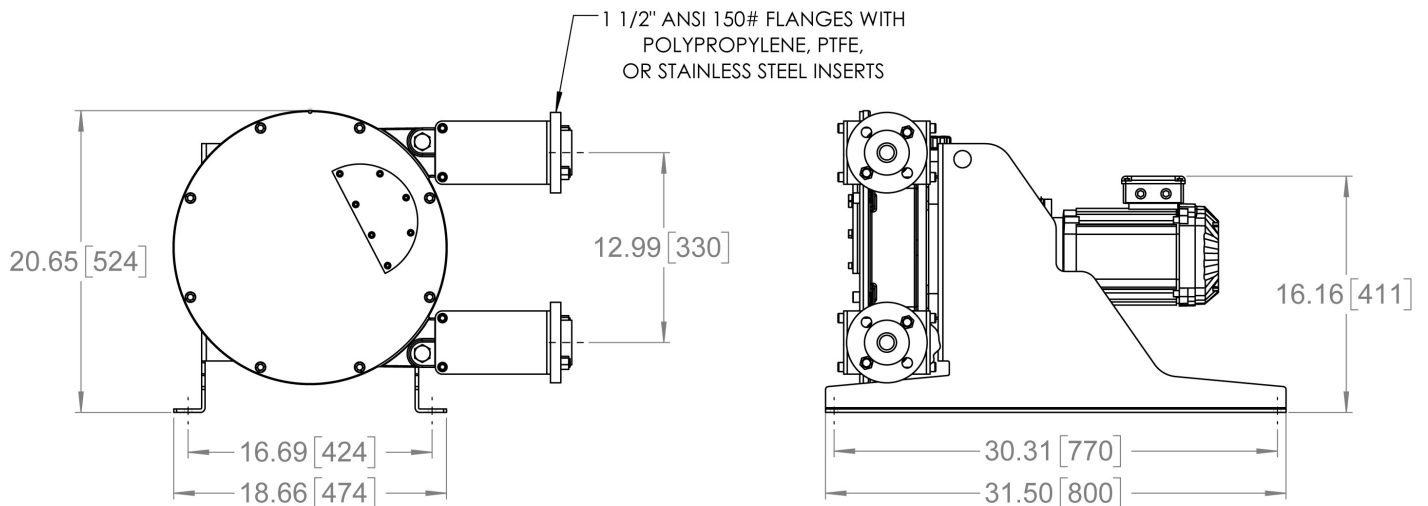

FLOMOTION SYSTEMS Inc.

3 North Main St.
Middleport, NY 14105
Tel: 716-691-3941

Email: info@flomotionsystems.com
www.flomotionsystems.com

