

# H21 SERIES

## INDUSTRIAL DUTY TUBING PUMPS

Designed to meet the demanding requirements of chemical injection, dispensing and transfer applications



Exceptional self-priming capabilities make the H21 Series an ideal choice for hard-to-handle chemicals such as sodium hypochlorite, hydrogen peroxide or viscous polymers.

An extremely wide range of flow outputs can be obtained by simply changing the tubing size or pump speed.

One size pumphead accepts six standard tubing sizes. The sealed, spring-loaded pumphead rollers provide extended tubing life and automatically compensate for minor variations in pump tube wall thickness.

The H21 Series pump features a unique sealed peristaltic pumphead, with optional leak detection, which protects against corrosive and dangerous chemical spills.



### **SAFETY FIRST - Sealed Pumphead Design - Tubing Rupture Detector**

An optional tubing rupture detector will automatically shut down the pump and signal an alarm in the event of a tubing leak.

Together, the unique sealed pump design and the Tubing Rupture Detector help to protect operators and other equipment from potentially dangerous fumes and chemicals.



**PERISTALTIC PUMPS**

## H21 SERIES FEATURES

- Flows to 48.5 GPH, Pressures to 100 psi.\*
- Accepts 6 different tubing sizes
- Spring-loaded roller assembly
- Sealed pumphead
- Rugged modular design
- Seal-less pumping technology
- Self-priming – suction lifts to 30 ft.
- No check valves – few moving parts
- Dry run capability
- Selectable manual or automatic control

\* Pressure rating dependent on tubing size.



# FLOMOTION H21 SERIES ENGINEERING SPECIFICATIONS

## GEARMOTOR / PUMPHEAD

- 3/8HP, TEFC inverter duty, gearmotor
- Oven-cured epoxy powder coat finish.
- Stainless Steel / ABS plastic pumphead.
- Spring-loaded roller assembly
- Weight (pump & controller): 28 lbs.

## K4-24 CONTROLLER

- Compact pump-mount with LED display
- Integral 8 button keypad
- Forward/Reverse capability
- NEMA 4X enclosure
- 115 / 230 VAC input 1-phase with 10' power cord
- 230VAC 3-phase output to motor
- Integral Power Disconnect (opt.)

## INTERFACING

- Remote or manual speed control input (4-20mA, DC voltage or frequency)
- Start/Stop control input
- Local/Remote Select input
- Tubing Rupture input
- Pump Running output (running/stopped)
- Speed Feedback output (4-20mA)
- Status output (auto/manual)
- Fault output

H21 Series Estimated Pumping Capacity*				RPM Range: 0.8 - 225		
Tubing Size (ID)	1.6mm (1/16")	3.2mm (1/8")	4.8mm (3/16")	6.4mm (1/4")	8mm (5/16")	9.6mm (3/8")
Max Pressure (psi)	100	100	80	60	30	30
ml/rev*	0.4	1.7	4.1	6.5	10.8	13.6
Flow Range GPH:	0.004 - 1.4 (0.3 - 90 ml/m)	0.01 - 6.1 (0.9 - 383 ml/m)	0.04 - 14.6 (2.8 - 923 ml/m)	0.06 - 23.2 (4 - 1,463 ml/m)	0.1 - 38.5 (8 - 2,430 ml/m)	0.1 - 48.5 (10 - 3,060 ml/m)
Continuous Duty Up To:	0.6 (40 ml/m)	2.7 (170 ml/m)	6.5 (410 ml/m)	10.3 (650 ml/m)	17.1 (1,080 ml/m)	21.6 (1,360 ml/m)
Medium Duty Up To:	1.1 (70 ml/m)	4.7 (298 ml/m)	11.4 (718 ml/m)	18.0 (1,138 ml/m)	30.0 (1,890 ml/m)	37.7 (2,380 ml/m)
Light Duty Up To:	1.4 (90 ml/m)	6.1 (383 ml/m)	14.6 (923 ml/m)	23.2 (1,463 ml/m)	38.5 (2,430 ml/m)	48.5 (3,060 ml/m)

### \*Recommended Use for Optimal Performance

Continuous Duty Cycle: 24/7/365 100rpm max.

Medium Duty Cycle: 12/7/365 175rpm max.

Light Duty Cycle: 1/7/365 240rpm max

Run time- No limit continuous max speed.

Run time- 6 hour continuous max speed/twice per day.

Run time- 1 hour continuous max speed/once per day.

Note: Above outputs based on water at no back pressure. Actual flow rates may vary.

AGENCY APPROVALS



## DIMENSIONS

in [mm]

### H21 Series Compact Mount

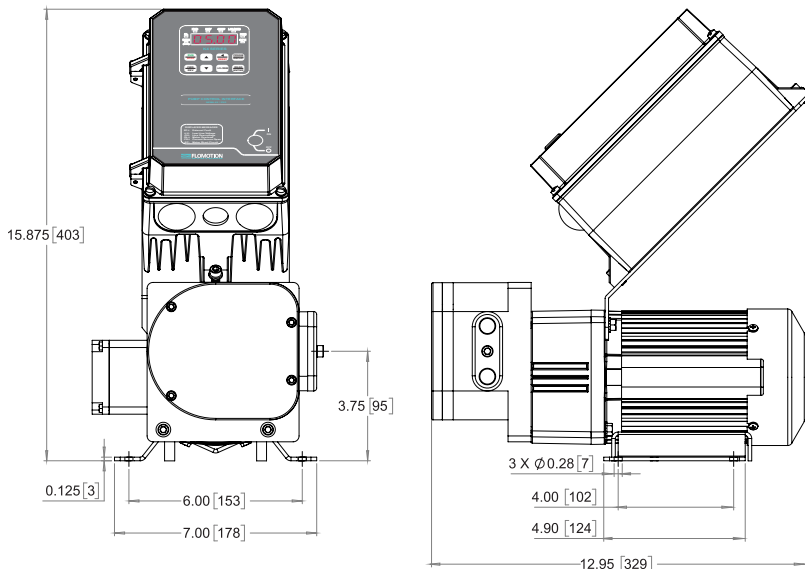

### K4-24 Controller

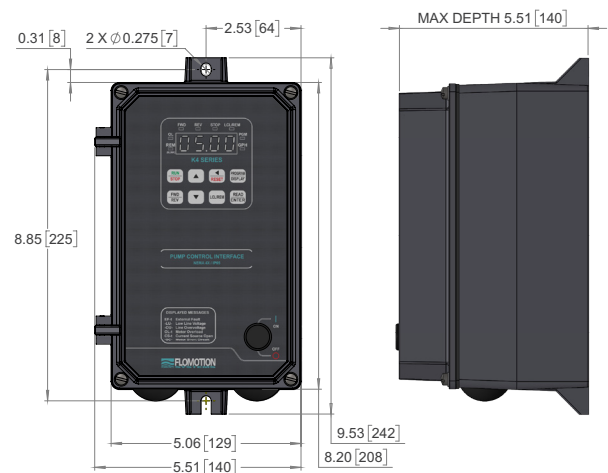

## FLOMOTION SYSTEMS Inc.

3 North Main St.

Middleport, NY 14105

Tel: 716-691-3941

Fax: 716-691-1253

Email: Info@FlomotionSystems.com

www.FlomotionSystems.com

