

INSTRUCTION MANUAL

# MS 2500



CE

---

## **INDEX**

<b>START UP AND MAINTENANCE OF THE INSTRUMENTS</b>	<b>_____ 1</b>
<b>INTRODUCTION</b>	<b>_____ 1</b>
<b>SAFETY</b>	<b>_____ 2</b>
<b>GENERAL INFORMATION ON THE SENSORS INSTALLATION</b>	<b>_____ 2</b>
<b>OPERATING TEMPERATURES</b>	<b>_____ 4</b>
<b>GROUNDING INSTRUCTIONS</b>	<b>_____ 5</b>
<b>TORQUES (NM) FOR FLANGED SENSOR'S BOLTS</b>	<b>_____ 6</b>

---

## INTRODUCTION

- This manual is integral part of the product. Read carefully the instructions contained since it contains important indications for the safety of use and of maintenance.
- The technical information and the relative products of this manual could be modified without any previous notice.
- The flow meter must be used for the use it has been built for. The improper use, possible tampering of the instrument or parts of it and substitutions of any components not original, makes the warranty to decay automatically.
- The manufacturer is considered responsible only if the instrument is used in its original configuration and setting.
- The flowmeter makes measures of liquids with conductivity greater than  $5\mu\text{S}/\text{cm}$ ; it consists of a sensor (described in this manual) and a converter, for it see the manual provided.
- If the sensor is supplied in compact version to the converter, consider the operating temperatures more restrictive, otherwise refer to the respective manuals.
- When transporting, unpacking and handling the flowmeter, be careful and care.
- In the case of prolonged storage and of transport, use and store in the original container in a dry place, do not place more than 3 packs one above the other.
- It is possible pallets storage and transport (in case of wooden crates do not place one above the other).
- For the cleaning of the device use only a damp cloth, and for the maintenance/repairs, contact the customer service.
- For the disposal of the device and of the packaging make strict reference to the regulations
- It is forbidden the reproduction of the present manual and of possible software supplied with the instrument.

## START UP AND MAINTENANCE OF THE INSTRUMENTS

- Before starting up the instrument, always make a sure connection to ground as suitable to page 5.
- Verify periodically: the cables integrity, the tightening of the sealing elements (cable glands, covers, etc.), the mechanical fixing of the instrument on the pipe or on the wall stand

## SAFETY



Before using the instrument, always make a sure connection to the ground



Avoid any attempt to repair the instrument. If the instrument is not functioning properly, please call the nearest assistance service



Pay maximum attention during the operations



ATTENTION !!!



DANGER !!!

## GENERAL INFORMATION ON THE SENSORS INSTALLATION

### FLOW DIRECTION

Before install the sensor locate the direction of the liquid in the piping

The sign of the flow rate is positive, when the flow direction is from - to + as printed on the tag plate.

If after the installation, for plant request becomes necessary reverse the sign of the flow, it is enough reverse the sign of the coefficient KA

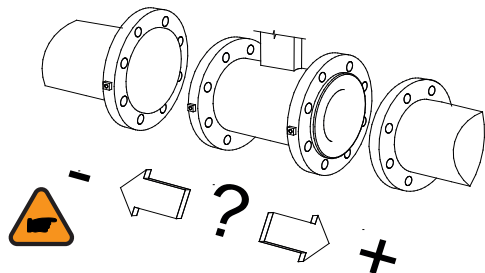







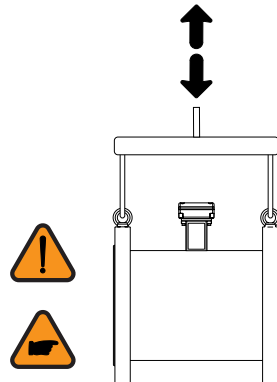





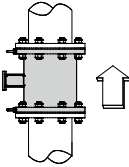

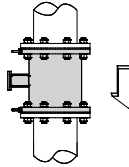

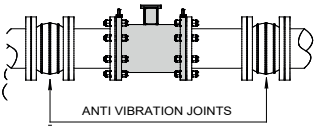

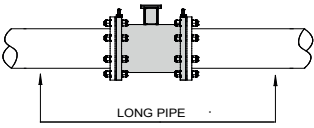

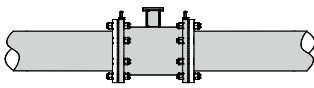
### LIFTING SENSORS

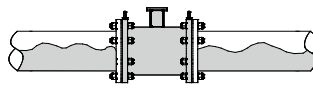
The sensors with eyebolts must be lifted by the method shown below.

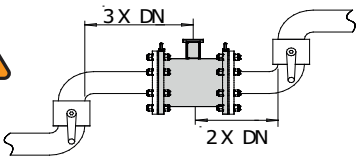
The eye-bolt are measured to sustain exclusively the weight of the meter

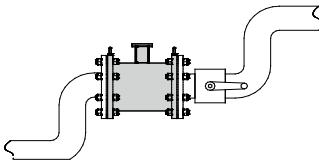

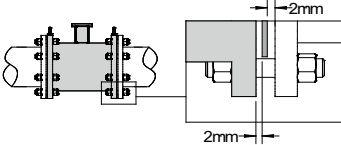
## SHREWDNESS AND PRECAUTIONS

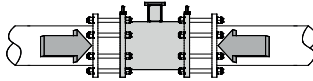
<p>In vertical installations an ascending flow is preferable. For vertical installations with descending flowdirection contact the manufacturer</p>			
 		 	
<p>For installations in long pipe lines, please use anti vibration joints</p>			
 	 <p style="text-align: center;">ANTI VIBRATION JOINTS</p>	 	 <p style="text-align: center;">LONG PIPE</p>
<p>Avoid a partially empty pipe, during operation the pipe must be either completely full of liquid or completely empty</p>			
 		 	
<p>Install the sensor away from bends and hydraulic accessories</p>			
 	 <p style="text-align: center;">3 X DN 2 X DN</p>	 	
<p>Avoid positioning flanges by tightening the nuts</p>			
 	 <p style="text-align: center;">2mm 2mm</p>	 	

## OPERATING TEMPERATURES

### CELSIUS

	LIQUID TEMPERATURE		AMBIENT TEMPERATURE	
	Min [°C]	Max [°C]	Min [°C]	Max [°C]
<b>RILSAN</b>	0	70	-5	60
<b>EBANITE</b>	-5	80	-5	60
<b>PP</b>	0	60	0	60
<b>PTFE</b>	-20	130 (100 Compact)	-10	60

### FAHRENEIT

	LIQUID TEMPERATURE		AMBIENT TEMPERATURE	
	Min [°F]	Max [°F]	Min [°F]	Max [°F]
<b>RILSAN</b>	32	158	23	140
<b>EBANITE</b>	23	176	23	140
<b>PP</b>	32	140	32	140
<b>PTFE</b>	-4	266 (212 compact)	14	140

## GROUNDING INSTRUCTIONS



For correct operation of the meter is **NECESSARY** that the sensor and the liquid are equipotential, so **ALWAYS** connect the sensor and converter to ground:

### GROUNDING WITH METALLIC PIPE

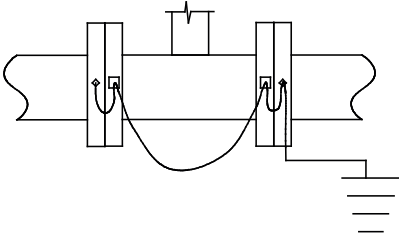

### GROUNDING WITH INSULATING PIPE

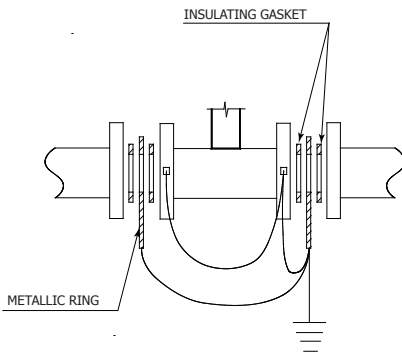

If the sensor has to be mounted on a pipe made of an insulating materials necessary:

- Install two metallic ring between the sensor flanges and the counter flanges of the pipe line
- or
- Use a sensor with the additional grounding electrode

### GROUNDING WHEN THERE IS A CATHODIC PROTECTION OVER THE PIPE

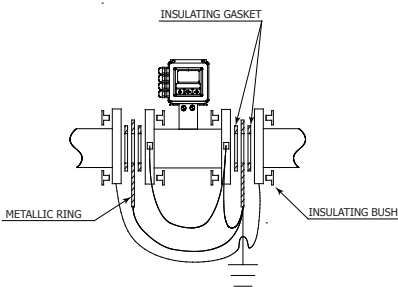

If the sensor must be install in the piping with a cathodic protection, is necessary:

- using insulating bushes to isolate the bolts
- Grounding metallic rings should be provided to ground the liquid using insulating gasket between the rings



**IMPORTANT:** The ripple of DC power source used for cathodic protection shall be = 0

## TORQUES (NM) FOR FLANGED SENSOR'S BOLTS

OPERATIVE PRESSURE										
Kpa	1000		1600			2500		4000		6400
psi	140		260			350		600		1000
DN	PTFE	EBON.	PTFE	EBON.	PP	PTFE	EBON.	PTFE	EBON.	EBON.
25			25 (21)		19	25		25 [32]		135 [95]
32			43 (26)		28	43		43 [40]		184 [115]
40			53 (32)		36	53		53 [63]		250 [184]
50			68 (60)		52	68		68 [35]		284 [101]
65			90 (78)		75	45		45 [53]		203 [156]
80			53 (89)		41	53		53 [68]		218 [200]
100			59 (70)		56	83		83 [94]		305 [273]
125			77 (94)		71	112		112 [130]		519 [380]
150			108 (106)		106	135		135 [113]		758 [328]
200	148	432	99 (148)	288 (433)		134	391	178 [178]	520 [519]	816 [519]
250	123	359	140 (156)	408 (455)		204	595	267 [185]	780 [540]	1124 [540]
300	142	415	175 (234)	510 (683)		201	588	278 [275]	812 [803]	1108 [803]
350	172	502	205 (325)	598 (946)		324	945	422 [318]	1231 [927]	1684 [927]
400	217	632	282 (312)	821 (911)		426	1243	619 [411]	1805 [1198]	2180 [1198]
450	194	564	281 (336)	981 (926)				[398]	[1161]	
500	224	652	382 (317)	1113 (924)				[465]	[1356]	
550			(379)	(1105)				[608]	[1772]	
600	323	942	568 (463)	1658 (1350)				[774]	[2258]	
650			(429)	(1251)				[753]	[2195]	
700	356	1040	421 (503)	1230 (1468)				[947]	[2761]	
750			(451)	(1315)				[1105]	[3223]	
800	476	1388	549	1603						
850			(563)	(1642)				[1373]	[4006]	
900	450	1312	519 (618)	1515 (1803)				[1408]	[4106]	
1000	582	1699	721 (736)	2105 (2146)				[1598]	[4662]	

- Tighten uniformly in diagonally opposite sequence
- The torque listed in tab are applicable to flanges: EN1092-1, DIN2501, BS4504, ANSI B16.5, JIS
- Is recommended the use of gaskets DIN 2690
- For DN > 1000 contact the manufacturer
- (\*\*\*)= ANSI 150
- [\*\*\*]= ANSI 300



## **PED CERTIFIED INSTRUMENTS**

These devices will be delivered with specific indications, in particular:

- On the instrument Label plate: a reference to the notified body (PED II only)
- On the Declaration of Conformity: a reference to the PED directive, to the harmonized standard connected to it and also a reference to the notified body (only if it's a PED II device)
- Addendum: The Risk analysis, a document to which it's important to pay the utmost attention

At the end of its lifetime, this product shall be disposed of in full compliance with the environmental regulations of the state in which it is located.

---

## MANUAL REVIEW

<b>REVIEW</b>	<b>DATE</b>	<b>DESCRIPTION</b>
MAN_MS2500_EN_IT_NL_R02	26/05/21	INTEGRATION: nomenclature update
MAN_MS2500_EN_IT_NL_R03	25/02/22	Operating temperatures update