

INSTRUCTION MANUAL

MS501

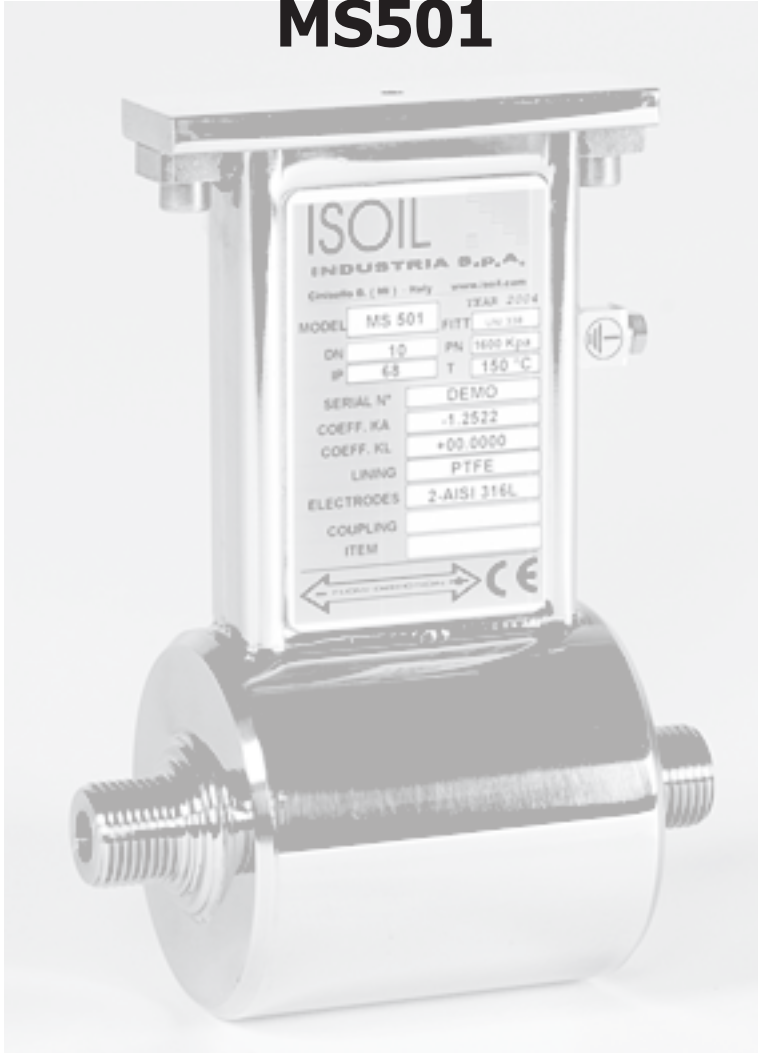

CE

INDEX

START UP AND MAINTENANCE OF THE INSTRUMENTS	1
INTRODUCTION	1
DEGREE OF PRODUCT CLEANLINESS	2
SAFETY	3
GENERAL INFORMATION ON THE SENSORS INSTALLATION	3
OVERALL DIMENSIONS	5
GROUNDING INSTRUCTIONS	11
OPERATIVE TEMPERATURE	11

INTRODUCTION

- This manual is integral part of the product. Read carefully the instructions contained since it contains important indications for the safety of use and of maintenance.
- The technical information and the relative products of this manual could be modified without any previous notice.
- The flow meter must be used for the use it has been built for. The improper use, possible tampering of the instrument or parts of it and substitutions of any components not original, makes the warranty to decay automatically.
- The manufacturer is considered responsible only if the instrument is used in its original configuration and setting.
- The flowmeter makes measures of liquids with conductivity greater than $5\mu\text{S}/\text{cm}$; it consists of a sensor (described in this manual) and a converter, for it see the manual provided.
- If the sensor is supplied in compact version to the converter, consider the operating temperatures more restrictive, otherwise refer to the respective manuals (page 11).
- When transporting, unpacking and handling the flowmeter, be careful and care.
- In the case of prolonged storage and of transport, use and store in the original container in a dry place, do not place more than 3 packs one above the other.
- It is possible pallets storage and transport (in case of wooden crates do not place one above the other).
- For the cleaning of the device use only a damp cloth, and for the maintenance/repairs, contact the customer service.
- For the disposal of the device and of the packaging make strict reference to the regulations
- It is forbidden the reproduction of the present manual and of possible software supplied with the instrument.

START UP AND MAINTENANCE OF THE INSTRUMENTS

- Before starting up the instrument, always make a sure connection to ground as suitable to page 11.
- Verify periodically: the cables integrity, the tightening of the sealing elements (cable glands, covers, etc.), the mechanical fixing of the instrument on the pipe or on the wall stand

DEGREE OF PRODUCT CLEANLINESS

The degree of cleaning of the product has been determined in accordance with the following standards

ASTM G 93-03: Cleaning Methods and Cleanliness Levels for Material and Equipment Used in Oxygen-Enriched Environments;

ASTM F331-05: Standard Test Method for Nonvolatile Residue of Solvent Extract from Aerospace Components (Using Flash Evaporator);

ASTM G 144-01: Standard Test Method for Determination of Residual Contamination of Materials and Components by Total Carbon Analysis Using a High Temperature Combustion Analyzer.

Par. 11.4.2.2 Total Organic Carbon:

When water is used as a quantitative verification, the ultrasonic extraction in aqueous phase is used to release organic substances and particulate from the surfaces of the fittings and from the piece to determine the total organic carbon.

G 136: Practice for Determination of Soluble Residual Contaminants in Materials by Ultrasonic Extraction

Non Volatile Residue (NVR) – Gravimetric test

From the evaluation of the NVR parameter, as gravimetric determination of processing residues, there is a level of cleaning of D band level for diameters up to DN 20 mm

For $DN > 20$ mm it is less than 33 mg / m² classifiable as band B.

Consequently, for $DN < 20$ mm, an additional washing cycle may be required by the user according to methods considered suitable for the use to which the product is destined and with liquids that are compatible with the materials of the product

Non Volatile Residue (NVR) - TOC

From the evaluation of the NVR parameter, such as determination of organic residues, the level of cleanliness is of band A, therefore the cleaning process carried out can be considered adequate and sufficient.

In any case, it is left to the discretion of the user to provide for additional cleaning deemed suitable for the use to which the product is destined and with liquids that are compatible with the materials of the product

SAFETY



Before using the instrument, always make a sure connection to the ground



Avoid any attempt to repair the instrument. If the instrument is not functioning properly, please call the nearest assistance service



Pay maximum attention during the operations



ATTENTION !!!



DANGER !!!

GENERAL INFORMATION ON THE SENSORS INSTALLATION

FLOW DIRECTION

Before install the sensor locate the direction of the liquid in the piping

The sign of the flow rate is positive, when the flow direction is from – to + as printed on the tag plate.

If after the installation, for plant request becomes necessary reverse the sign of the flow, it is enough reverse the sign of the coefficient KA

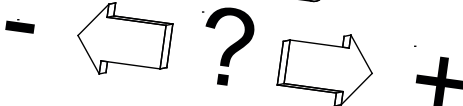
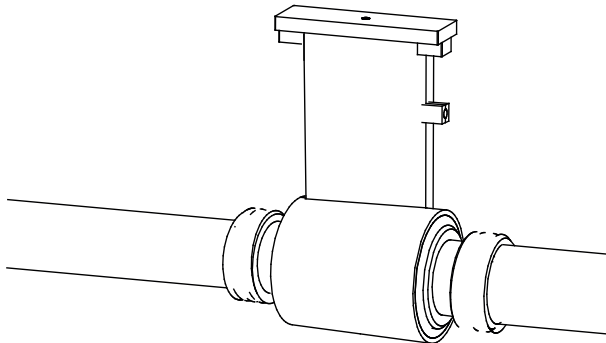

SHREWDNESS AND PRECAUTIONS

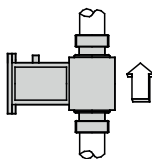
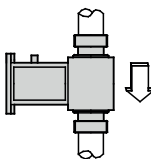
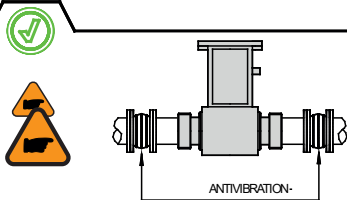
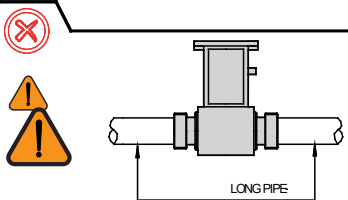
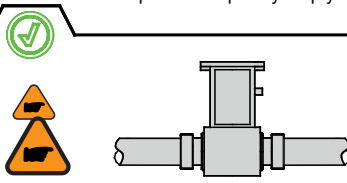
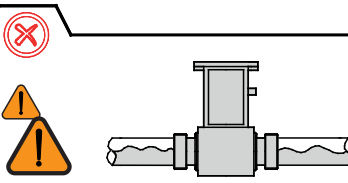
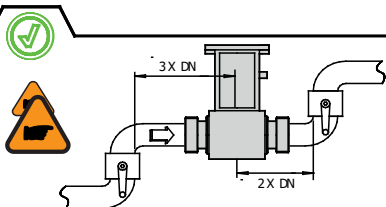
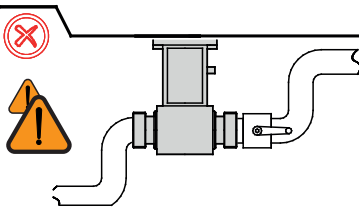
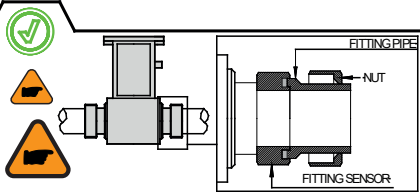
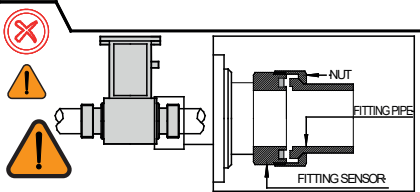
<p>In vertical installations an ascending flow is preferable. For vertical installations with descending flow direction contact the manufacturer</p>	
<p>✓</p> 	<p>✗</p> 
<p>For installations in long pipe lines, please use anti vibration joints</p>	
<p>✓</p>  <p>ANTIVIBRATION-</p>	<p>✗</p>  <p>LONG PIPE</p>
<p>Avoid a partially empty pipe, during operation the pipe must be either completely full of liquid or completely empty</p>	
<p>✓</p> 	<p>✗</p> 
<p>Install the sensor away from bends and hydraulic accessories</p>	
<p>✓</p>  <p>3X DN</p> <p>2X DN</p>	<p>✗</p> 
<p>Avoid positioning fittings by tightening the clamps.</p>	
<p>✓</p>  <p>FITTING PIPE</p> <p>NUT</p> <p>FITTING SENSOR</p>	<p>✗</p>  <p>FITTING PIPE</p> <p>NUT</p> <p>FITTING SENSOR</p>

OVERALL DIMENSIONS

GAS/NPT WITHOUT LINING

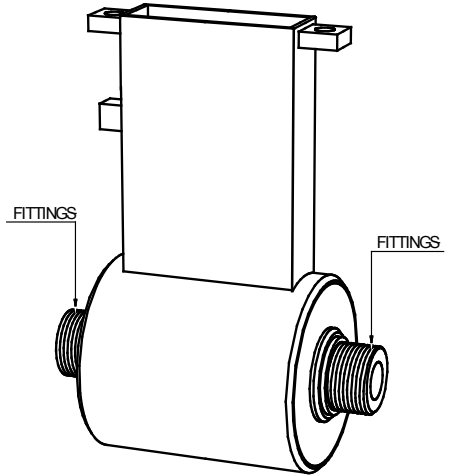
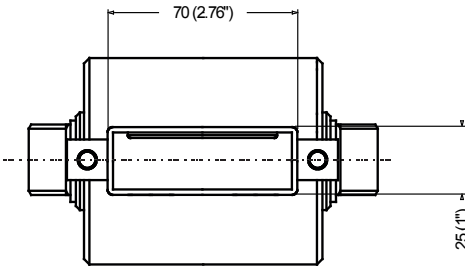
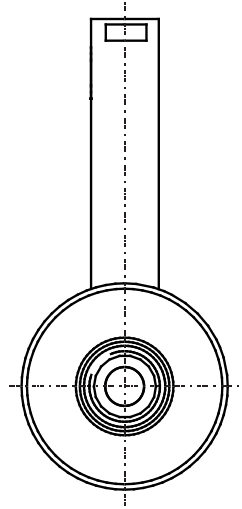
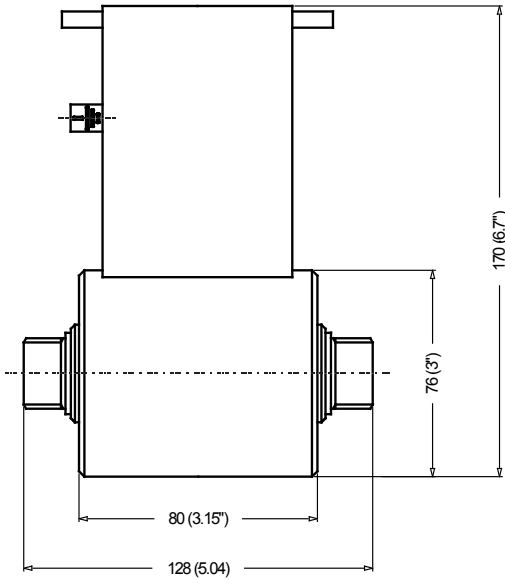

CONNECTIONS GAS/NPT (STAINLESS STEEL WITHOUT LINING)					
DIMENSIONS mm (inches)	DN				
	3 (1/8")	6 (1/4)	10 (3/8)	15 (1/2")	20 (3/4")
FITTINGS	1/4"	3/8"	1/2"	3/4"	1"

OVERALL DIMENSIONS GAS/NPT WITH LINING

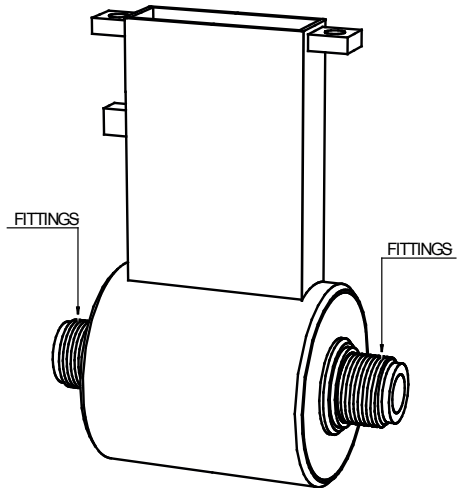
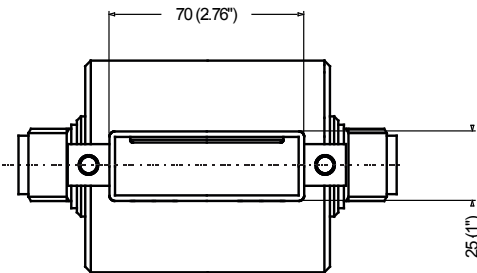
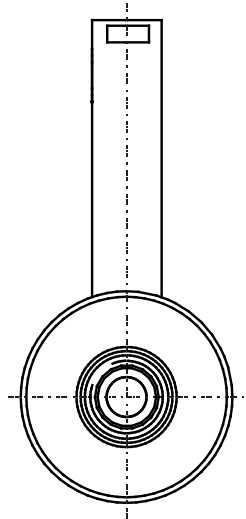
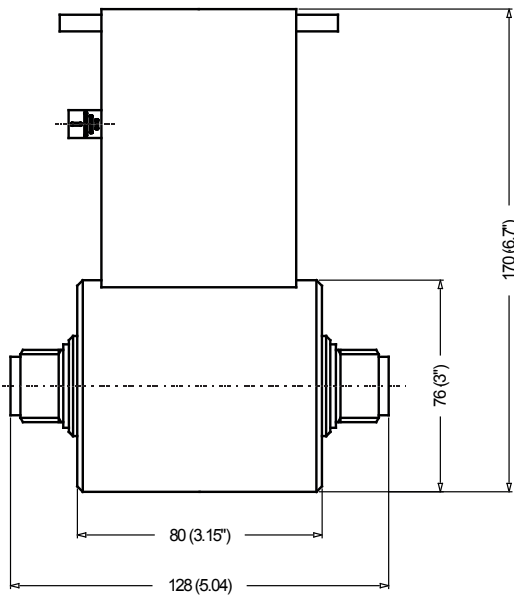

CONNECTIONS GAS/NPT (WITH LINING)					
DIMENSIONS mm (inches)	DN				
	3 (1/8")	6 (1/4)	10 (3/8)	15 (1/2")	20 (3/4")
FITTINGS	1/2"	1/2"	3/4"	1"	1" 1/4"

OVERALL DIMENSIONS FLANGED WITHOUT LINING

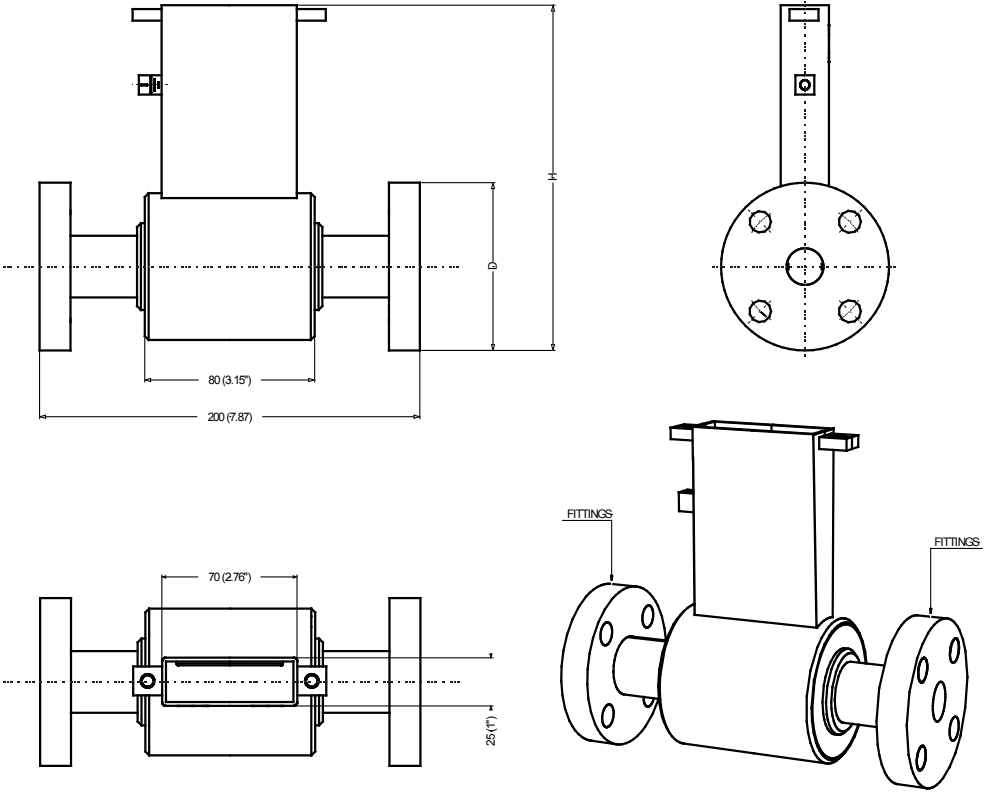

FLANGE CONNECTIONS UNI (STAINLESS STEEL WITHOUT LINING)					
DIMENSIONS mm (inches)	DN				
	3 (1/8")	6 (1/4)	10 (3/8)	15 (1/2")	20 (3/4")
D	90 (3.54)	90 (3.54)	90 (3.54)	95 (3.74)	105 (4.13)
H	183 (7.20)	183 (7.20)	183 (7.20)	186 (7.30)	191 (7.5)
FITTINGS	DN 10	DN 10	DN 10	DN 15	DN 20

FLANGE CONNECTIONS ANSI (STAINLESS STEEL WITHOUT LINING)					
DIMENSIONS mm (inches)	DN				
	3 (1/8")	6 (1/4)	10 (3/8)	15 (1/2")	20 (3/4")
D	88.9 (3.5)	88.9 (3.5)	88.9 (3.5)	88.9 (3.5)	98.4 (3.87)
H	183 (7.20)	183 (7.20)	183 (7.20)	183 (7.20)	188 (7.37)
FITTINGS	1/2"	1/2"	1/2"	1/2"	3/4"

OVERALL DIMENSIONS FLANGED WITH LINING

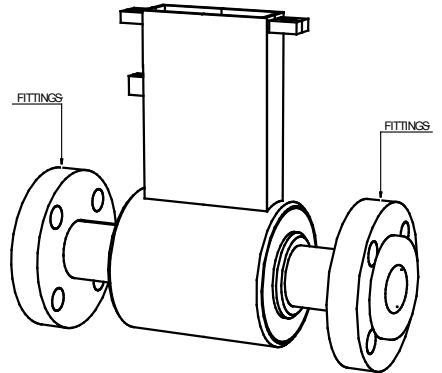
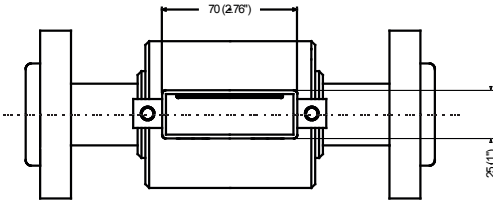
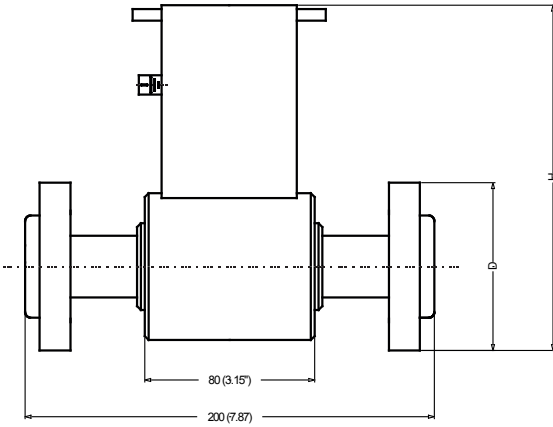

FLANGE CONNECTIONS UNI (PTFE LINING)					
DIMENSIONS mm (inches)	DN				
		3 (1/8")	6 (1/4)	10 (3/8)	15 (1/2")
D	90 (3.54)	90 (3.54)	90 (3.54)	95 (3.74)	105 (4.13)
H	183 (7.20)	183 (7.20)	183 (7.20)	186 (7.30)	191 (7.5)
FITTINGS	DN 10	DN 10	DN 10	DN 15	DN 20

FLANGE CONNECTIONS ANSI (PTFE LINING)					
DIMENSIONS mm (inches)	DN				
		3 (1/8")	6 (1/4)	10 (3/8)	15 (1/2")
D	88.9 (3.5)	88.9 (3.5)	88.9 (3.5)	88.9 (3.5)	98.4 (3.87)
H	183 (7.20)	183 (7.20)	183 (7.20)	183 (7.20)	188 (7.37)
FITTINGS	1/2"	1/2"	1/2"	1/2"	3/4"

OVERALL DIMENSIONS SANITARY CLAMP CONNECTIONS

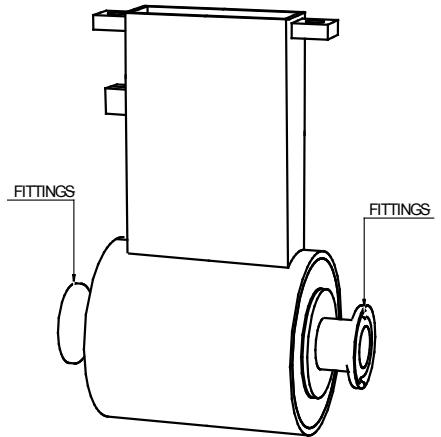
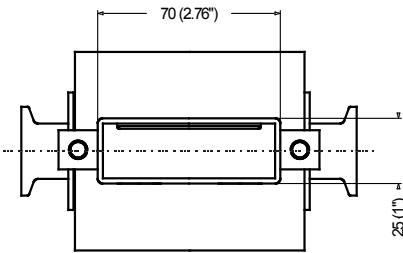
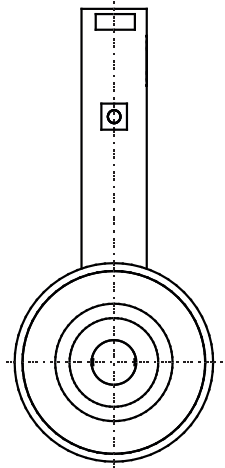
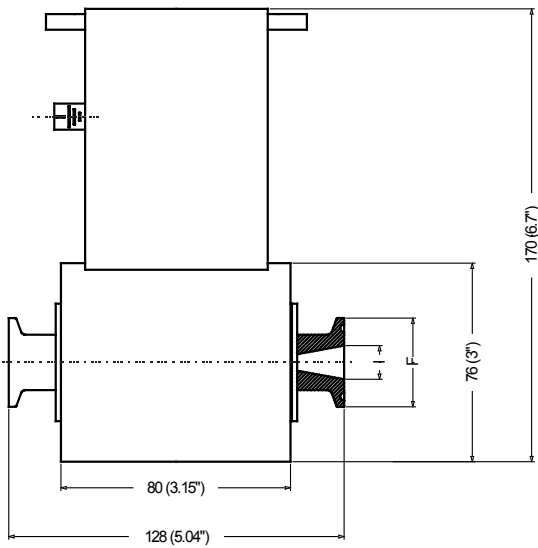

CLAMP ISO 2852					
DIMENSIONS mm (inches)	DN				
	I	3 (1/8")	6 (1/4)	10 (3/8)	15 (1/2")
F	12.7(0.5)	12.7(0.5)	12.7(0.5)	17.2(0.68)	21.3 (0.84)
F	34 (1.34)	34 (1.34)	34 (1.34)	34 (1.34)	34 (1.34)

CLAMP BS4825					
DIMENSIONS mm (inches)	DN				
	I	3 (1/8")	6 (1/4)	10 (3/8)	15 (1/2")
F	9.5 (0.37)	9.5 (0.37)	9.5 (0.37)	15.85 (0.62)	22.2 (0.87)
F	25.4 (1)	25.4 (1)	25.4 (1)	25.4 (1)	50.5 (1.99)

OVERALL DIMENSIONS SANITARY DIN/SMS

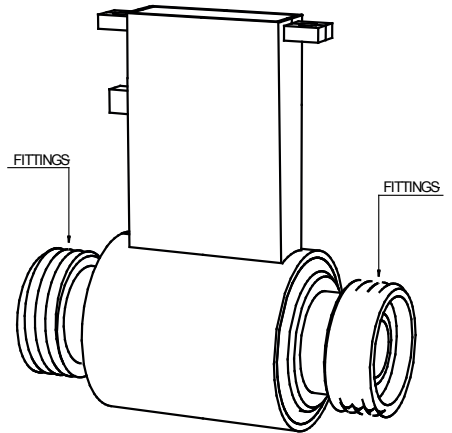
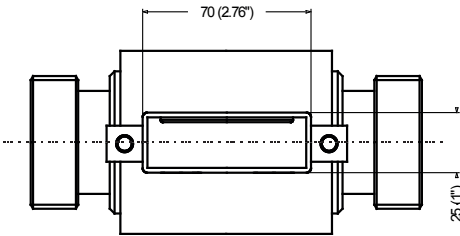
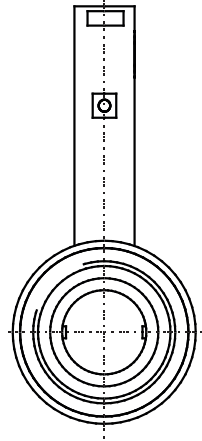
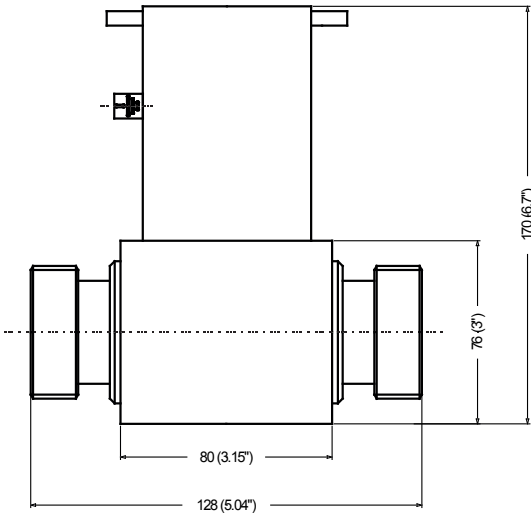

DIN 11851					
DIMENSIONS mm (inches)	DN				
		3 (1/8")	6 (1/4)	10 (3/8)	15 (1/2")
FITTINGS	DN 10	DN 10	DN 10	DN 15	DN 20

SMS 1146			
DIMENSIONS mm (inches)	DN		
		10 (3/8)	15 (1/2")
FITTINGS	DN 25	DN 25	DN 25

GROUNDING INSTRUCTIONS



For correct operation of the meter is NECESSARY that the sensor and the liquid are equipotential, so ALWAYS connect the sensor and converter to ground:

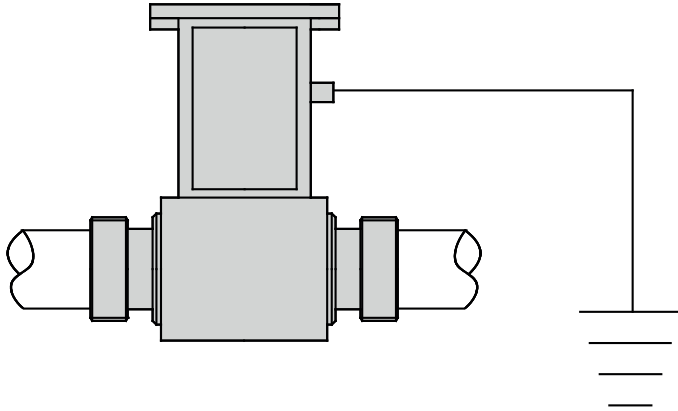

OPERATIVE TEMPERATURE

VERSION	LIQUID TEMPERATURE		AMBIENT TEMPERATURE
	OTHER CONVERTERS	ML-4F1	
COMPACT	-20°C ÷ 100°C -4°F ÷ 212°F	-20°C ÷ 130°C -4°F ÷ 266°F	-10 °C ÷ 60 °C 14°F ÷ 140°F
SEPARATE	-20°C ÷ 110°C -4°F ÷ 230°F		

At the end of its lifetime, this product shall be disposed of in full compliance with the environmental regulations of the state in which it is located.

MANUAL REVIEWS

REVIEW	DATE	DESCRIPTION
MAN_501_EN_IT_NL_R01	25/05/2021	INTEGRATION: NOMENCLATURE UPDATED

