



ISOMAG 

The friendly magmeter

MANUALE

MODBUS PROTOCOL MV110-MV210

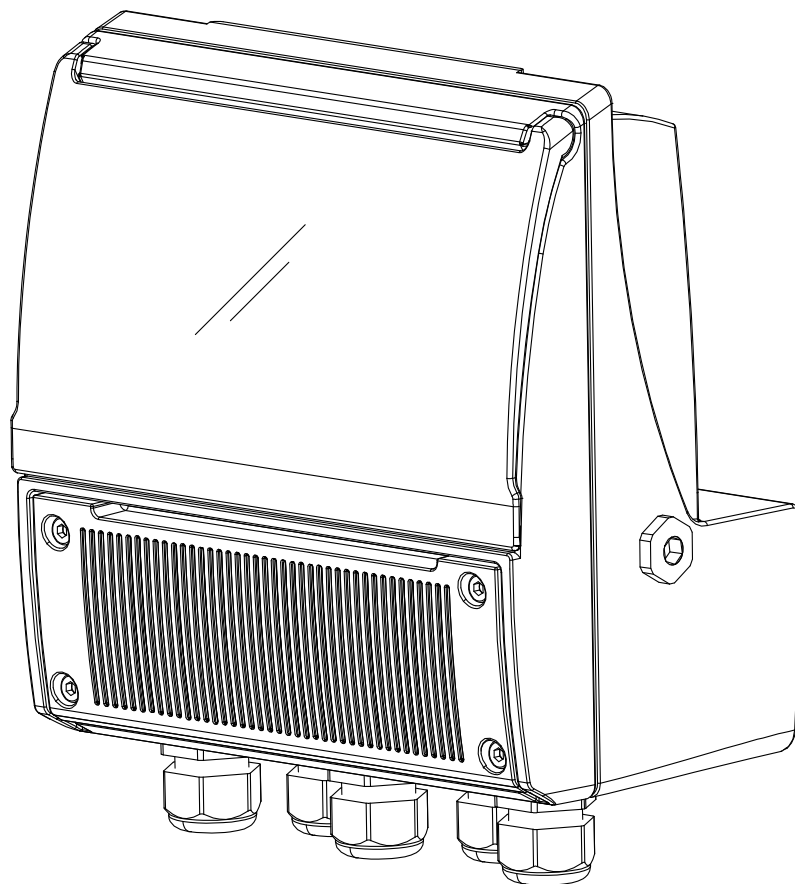

CE

ISOIL 
INDUSTRIA



INDEX

MV110 - MODBUS PROTOCOL	2
FUNCTION 04: READ PROCESS VARIABLE	3
FUNCTION 05: ACTIVATE FUNCTIONS	6
FUNCTION 08: DIAGNOSTICS	7
FUNCTION 110: EXCHANGE MCP COMMANDS	7
MV210 - MODBUS PROTOCOL	8
FUNCTION 04: READ PROCESS VARIABLE	9
ACTIVATE FUNCTIONS: FUNCTION 05	12
FUNCTION 08: DIAGNOSTICS	13
FUNCTION 16: WRITE MULTIPLE REGISTERS	13
FUNCTION 110: EXCHANGE MCP COMMANDS	13
MANUAL REVIEWS	15

MV110 - MODBUS PROTOCOL

RS485 HARDWARE CONNECTION

For the hardware connection see the relative section in this manual and MODBUS manual.

Data word format

The data bytes travelling in serial form on the communication line are enclosed in words which have a fixed length of 10 bits:

1 START BIT

8 DATA BITS = 1 DATA BYTE

1 STOP BIT

Each word contains one byte of data plus additional bits which serve to synchronise and make the communication safer. These extra bits are added automatically in the transmission phase by the transmitter integrated circuit. In the reception phase, the reverse operation is executed by the receiver integrated circuit:

the eight data bits are extracted and the others eliminated. These operations are executed entirely on a hardware level. The 8 data bits must be serialised starting from bit 0 (the least significant one).

Communication speed

The millennium series instruments have 4 communication speeds:

4800 bps

9600 bps

19200 bps

38400 bps

Serial port settings

Serial port setting:

Data bits: 8

Parity: Manu < 7-Communication >, function - < Parity >

Stop bits: 1

Flow control: none (no control lines no xon/xoff characters used)

General description

All data are sent in groups of 16 bits registers. The format used is BIG ENDIAN, MSB byte is sent first, LSB is sent last. When a variable is more than 16 bits in size, it uses two adjacent registers. The totalizer values are expressed as integer numbers. For the correct representation of the value in case there is a fractional part, the decimal dot must be placed in the position specified by the next variable register following the totalized value. All values relative to the flow rate are averaged. The number of samples that compose the average value varies depending on the measure sample rate and the MODBUS reading requests. Example: measure sample rate = 50 Hz, MODBUS reading frequency = 10 Hz, Number of samples used for average calculation = $50/10 = 5$.

FUNCTION 04: READ PROCESS VARIABLE

ADDRESS	SIZE	TYPE OF DATA	MEANING
0000-0001	2 registers 32 bits	FLOAT	full scale flow rate in the unit of measure chosen (as can be seen in the display of the instrument)
0002-0003	2 registers 32 bit	FLOAT	flow rate value in percentage
0004-0005	2 registers 32 bits	FLOAT	flow rate value in the unit of measure chosen
0006-0007	2 registers 32 bits	FLOAT	Flow speed in the unit of measure chosen (m/s or ft/s)
0008-0009	2 registers 32 bits	UNSIGNED LONG	Totalizer T+ value
0010	1 register 8+8 bits	TWO BYTES	First byte (MSB): number of overflows recorded, second byte (LSB): number of decimal places
0011-0012	2 registers 32 bits	UNSIGNED LONG	Totalizer P+ value
0013	1 register 8+8 bits	TWO BYTES	First byte (MSB): number of overflows recorded, second byte (LSB): number of decimal places
0014-0015	2 registers 32 bits	UNSIGNED LONG	totalizer T- value
0016	1 register 8+8 bits	TWO BYTES	First byte (MSB): number of overflows recorded, second byte (LSB): number of decimal places
0017-0018	2 registers 32 bits	UNSIGNED LONG	Totalizer P- value
0019	1 register 8+8 bits	TWO BYTES	First byte (MSB): number of overflows recorded, second byte (LSB): number of decimal places
0020	1 register 8+8 bits	TWO BYTES	first byte (MSB): process flags 1, (LSB): process flags 2
0021	1 register 16 bits	UNSIGNED SHORT	Number of measure samples used for to calculate the latest read average value of flow rate
0022	1 register 16 bits	UNSIGNED SHORT	Equivalent resistance measured between electrode E1 and the common point, in kilo ohm
0023	1 register, 16 bits	UNSIGNED SHORT	equivalent resistance measured between electrode E2 and the common point, in kilo ohm
0024	1 register, 16 bits	SIGNED SHORT	voltage measured between electrode E1 and the common point, in millVolts
0025	1 register, 16 bits	SIGNED SHORT	voltage measured between electrode E2 and the common point, in millVolts
0026	1 register, 16 bits	UNSIGNED SHORT	voltage measured at rechargeable terminals, in milliVolts
0027	1 register, 16 bits	UNSIGNED SHORT	residual battery capacity in percentage
0028	1 register, 16 bits	SIGNED SHORT	CPU temperature in the unit of measure chosen
0029	1 register, 16 bits	SIGNED SHORT	Board temperature T1 the unit of measure chosen
0030	1 register, 16 bits	SIGNED SHORT	Board temperature T2 the unit of measure chosen
0031	1 register, 16 bits	SIGNED SHORT	Flow sensor coil's temperature the unit of measure chosen
0032-0033	2 register, 32 bits	UNSIGNED LONG	latest sensor test result code
0034	1 register, 16 bits	UNSIGNED SHORT	number of alarms currently active
0035-0036	2 register, 32 bits	UNSIGNED LONG	board's serial number
0037	1 register, 16 bits	UNSIGNED SHORT	flow rate unit and decimals

0038	1 register, 16 bits	UNSIGNED SHORT	Totalizer T+ unit and decimals
0039	1 register, 16 bits	UNSIGNED SHORT	Totalizer P+ unit and decimals
0040	1 register, 16 bits	UNSIGNED SHORT	Totalizer T- unit and decimals
0041	1 register, 16 bits	UNSIGNED SHORT	Totalizer P- unit and decimals

Meaning and value of the process flags 1 returned with the register 0020 (MSB):

- bit 7 (MSB): flow rate alarm MIN (flow rate below the minimum threshold set)
- bit 6: flow rate alarm MAX (flow rate over the maximum threshold set)
- bit 5: flow rate sign (1 = negative)
- bit 4: flow rate below the cut-off value
- bit 3: measure range active (0= range 1, 1= range 2)
- bit 2: flow rate measure reset value status (1= measure is forcibly reset to zero)
- bit 1: volume counters lock status (1= counters are locked)
- bit 0 (LSB): internal use, no meaning

Meaning and value of the process flags 2 returned with the register 0020 (LSB):

- bit 7 (MSB): flow rate overflow (value greater than full scale)
- bit 6: pulse channel #2 overflow (frequency greater than maximum possible for the given parameters)
- bit 5: pulse channel #1 overflow (frequency greater than maximum possible for the given parameters)
- bit 4: measure signal amplitude out of A/D converter range
- bit 3: measure signal amplitude out of amplifier capability
- bit 2: input signal error (out of input chain capability)
- bit 1: coils excitation error
- bit 0: (LSB): pipe empty

Meaning and value of the sensor test flags returned with the register 0032(MSW):

- bits 15-03 (MSB): reserved
- bit 02: empty pipe
- bit 01: reference values not set
- bit 0 (LSB) excitation error

Meaning and value of the sensor test flags returned with the register 0033 (LSW):

- bit 15 (MSB): resistance at electrode E2 is outside the limits respect to the reference value
- bit 14 : resistance at electrode E1 is outside the limits respect to the reference value
- bit 13: coil time B is outside the limits respect to the reference value
- bit 12: coil time A is outside the limits respect to the reference value
- bit 11: coil temperature is outside the limits respect to the reference value
- bit 10: coil leakage current is outside the limit
- bit 09: coil driver output 2 voltage is out of tolerance during test phase 3
- bit 08: coil driver output 1 voltage is out of tolerance during test phase 3
- bit 07: coil driver output 2 voltage is out of tolerance during test phase 2
- bit 06: coil driver output 1 voltage is out of tolerance during test phase 2
- bit 05: coil driver output 2 voltage is out of tolerance during test phase 1
- bit 04: coil driver output 1 voltage is out of tolerance during test phase 1
- bit 03: coil driver power generator voltage is out of tolerance during test phase 2
- bit 02: coil driver power generator voltage is out of tolerance during test phase 1
- bit 01: coil driver power generator value is out of tolerance during test phase 2
- bit 00 (LSB): coil driver power generator value is out of tolerance during test phase 1

Meaning and value of the unit of measures registers 0037, 0038, 0039, 0040, 0041:

- bit 15 (MSB) 0 = unit is metric, 1 = unit is imperial
- bit 14 0 = volume unit, 1 = weight unit
- bits 13-08 index of unit of measure (unit kind depend on bits 14 and 15, see below)
- bits 07-05 reserved
- bits 04-02 decimal point position (number of digits after the decimal dot)
- bits 01-00 (LSB) time unit (for flow rate only): 0= day, 1=hour, 2=minute, 3=second

Index of metric volume units for flow rate, totalizers

- 00 ml (milliliter = 0.001 liter)
- 01 cm³ (cubic centimeter = 0.001 liter)
- 02 l (liter)
- 03 dm³ (cubic decimeter = 1 liter)
- 04 dal (decaliter = 10 liters)
- 05 hl (hectoliter = 100 liters)
- 06 m³ (cubic meter = 1000 liters)
- 07 Ml (Megaliter = 1000000 liters)

The manufacturer guarantees only English text available on our web site www.isoil.com

Index of imperial volume units for flow rate, totalizers

00	in3	(cubic inches)
01	Gal	(US gallon)
02	IGL	(UK gallon)
03	ft3	(cubic feet)
04	bbl	(standard barrel)
05	BBL	(oil barrel)
06	hf3	(hundred cubic feet = 100 cubic feet)
07	KGL	(kilo-US gallon = 1000 US gallons)
08	IKG	(kilo-UK gallon = 1000 UK gallons)
09	kf3	(kilo-cubic feet = 1000 cubic feet)
10	ttG	(ten-thousand US gallon = 10000 US gallons)
11	Aft	(acre feet)
12	MGL	(Mega-US gallon = 1000000 US gallons)
13	IMG	(Mega-UK gallon = 1000000 UK gallons)

Index of metric weight units for flow rate, totalizers

00	g	(gram)
01	kg	(kilogram = 1000 grams)
02	t	(metric ton 0 1000000 grams)

Index of imperial weight units for flow rate, totalizers

00	oz	(ounce = 1/16 lb)
01	lb	(pound)
02	ton	(short ton)

FUNCTION 05: ACTIVATE FUNCTIONS

ADDRESS	SIZE	TYPE OF DATA	FUNCTION VALUE	MEANING
0000	1 REGISTER, 16 BITS	UNSIGNED SHORT	0XFF00 (HEX)	Reset the enabled totalizers (same totalizer enabled for reset from digital input).
0001	1 REGISTER, 16 BITS	UNSIGNED SHORT	0XFF00 (HEX)	enable or disable the sensor's excitation (toggle excitation status)

FUNCTION 08: DIAGNOSTICS

SUB.- FUNCTION CODE	SIZE	TYPE OF DATA	FUNCTION / VALUE
0000	1 REGISTER, 16 BITS	UNSIGNED SHORT	RETURN QUERY DATA
0001	1 REGISTER, 16 BITS	SIGNED SHORT	RESTART COMMUNICATION
0004	1 REGISTER, 16 BITS	SIGNED SHORT	ACTIVATE LISTEN MODE
0010	1 REGISTER, 16 BITS	SIGNED SHORT	CLEAR DIAGNOSTIC COUNTERS
0011	1 REGISTER, 16 BITS	UNSIGNED SHORT	NUMBER OF TOTAL RECEIVED PACKETS
0012	1 REGISTER, 16 BITS	UNSIGNED SHORT	NUMBER OF RECEIVED PACKETS WITH CRC ERROR
0013	1 REGISTER, 16 BITS	UNSIGNED SHORT	NUMBER OF RECEIVED PACKETS WITH EXCEPTION ERROR
0014	1 REGISTER, 16 BITS	UNSIGNED SHORT	NUMBER OF ADDRESSED OR BROADCAST RECEIVED PACKETS
0015	1 REGISTER, 16 BITS	UNSIGNED SHORT	NUMBER OF BROADCAST RECEIVED PACKETS
0016	1 REGISTER, 16 BITS	UNSIGNED SHORT	NUMBER OF RECEIVED PACKETS WITH NAK FLAG
0017	1 REGISTER, 16 BITS	UNSIGNED SHORT	NUMBER OF RECEIVED PACKETS WITH BUSY FLAG
0018	1 REGISTER, 16 BITS	UNSIGNED SHORT	NUMBER OF RECEIVED PACKETS WITH OVERRUN FLAG

FUNCTION 110: EXCHANGE MCP COMMANDS

This function permits to send MCP encapsulated commands into MODBUS packets.

Maximum allowed = 250 bytes of payload, data are NOT structured in 16-bit words as MODBUS standard, but 8-bits ascii characters strings instead.

See MCP manual for commands structure and syntax.

Reply to MCP commands sent must fit into 250 bytes packet size.

MV210 - MODBUS PROTOCOL

RS485 HARDWARE CONNECTION

For the hardware connection see the relative section in this manual and MODBUS manual.

DATA WORD FORMAT

The data bytes travelling in serial form on the communication line are enclosed in words which have a fixed length of 10 bits:

- 1 START BIT
- 8 DATA BITS = 1 DATA BYTE
- 1 STOP BIT

Each word contains one byte of data plus additional bits which serve to synchronise and make the communication safer. These extra bits are added automatically in the transmission phase by the transmitter integrated circuit. In the reception phase, the reverse operation is executed by the receiver integrated circuit:

the eight data bits are extracted and the others eliminated. These operations are executed entirely on a hardware level. The 8 data bits must be serialised starting from bit 0 (the least significant one).

COMMUNICATION SPEED

The millennium series instruments have 4 communication speeds:

- 4800 bps
- 9600 bps
- 19200 bps
- 38400 bps

SERIAL PORT SETTINGS

Serial port setting:

Data bits: 8

Parity: Manu < 7-Communication >, function - < Parity >

Stop bits: 1

Flow control: none (no control lines no xon/xoff characters used)

GENERAL DESCRIPTION

All data are sent in groups of 16 bits registers. The format used is BIG ENDIAN, MSB byte is sent first, LSB is sent last. When a variable is more than 16 bits in size, it uses two adjacent registers. The totalizer values are expressed as integer numbers. For the correct representation of the value in case there is a fractional part, the decimal dot must be placed in the position specified by the next variable register following the totalized value. All values relative to the flow rate are averaged. The number of samples that compose the average value varies depending on the measure sample rate and the MODBUS reading requests. Example: measure sample rate = 50 Hz, MODBUS reading frequency = 10 Hz, Number of samples used for average calculation = $50/10 = 5$.

FUNCTION 04: READ PROCESS VARIABLE

ADDRESS	SIZE	TYPE OF DATA	MEANING
0000-0001	2 registers 32 bits	FLOAT	full scale flow rate in the unit of measure chosen (as can be seen in the display of the instrument)
0002-0003	2 registers 32 bit	FLOAT	flow rate value in percentage
0004-0005	2 registers 32 bits	FLOAT	flow rate value in the unit of measure chosen
0006-0007	2 registers 32 bits	FLOAT	Flow speed in the unit of measure chosen (m/s or ft/s)
0008-0009	2 registers 32 bits	UNSIGNED LONG	Totalizer T+ value
0010	1 register 8+8 bits	TWO BYTES	First byte (MSB): number of overflows recorded, second byte (LSB): number of decimal places
0011-0012	2 registers 32 bits	UNSIGNED LONG	Totalizer P+ value
0013	1 register 8+8 bits	TWO BYTES	First byte (MSB): number of overflows recorded, second byte (LSB): number of decimal places
0014-0015	2 registers 32 bits	UNSIGNED LONG	totalizer T- value
0016	1 register 8+8 bits	TWO BYTES	First byte (MSB): number of overflows recorded, second byte (LSB): number of decimal places
0017-0018	2 registers 32 bits	UNSIGNED LONG	Totalizer P- value
0019	1 register 8+8 bits	TWO BYTES	First byte (MSB): number of overflows recorded, second byte (LSB): number of decimal places
0020	1 register 8+8 bits	TWO BYTES	first byte (MSB): process flags 1, (LSB): process flags 2
0021	1 register 16 bits	UNSIGNED SHORT	Number of measure samples used for to calculate the latest read average value of flow rate
0022	1 register 16 bits	UNSIGNED SHORT	Equivalent resistance measured between electrode E1 and the common point, in kilo ohm
0023	1 register, 16 bits	UNSIGNED SHORT	equivalent resistance measured between electrode E2 and the common point, in kilo ohm
0024	1 register, 16 bits	SIGNED SHORT	voltage measured between electrode E1 and the common point, in millVolts
0025	1 register, 16 bits	SIGNED SHORT	voltage measured between electrode E2 and the common point, in millVolts
0026	1 register, 16 bits	UNSIGNED SHORT	voltage measured at rechargeable terminals, in milliVolts
0027	1 register, 16 bits	UNSIGNED SHORT	residual battery capacity in percentage
0028	1 register, 16 bits	SIGNED SHORT	CPU temperature in the unit of measure chosen
0029	1 register, 16 bits	SIGNED SHORT	Board temperature T1 the unit of measure chosen
0030	1 register, 16 bits	SIGNED SHORT	Board temperature T2 the unit of measure chosen
0031	1 register, 16 bits	SIGNED SHORT	Flow sensor coil's temperature the unit of measure chosen

0032-0033	2 register, 32 bits	UNSIGNED LONG	latest sensor test result code
0034	1 register, 16 bits	UNSIGNED SHORT	number of alarms currently active
0035-0036	2 register, 32 bits	UNSIGNED LONG	board's serial number
0037	1 register, 16 bits	UNSIGNED SHORT	flow rate unit and decimals
0038	1 register, 16 bits	UNSIGNED SHORT	Totalizer T+ unit and decimals
0039	1 register, 16 bits	UNSIGNED SHORT	Totalizer P+ unit and decimals
0040	1 register, 16 bits	UNSIGNED SHORT	Totalizer T- unit and decimals
0041	1 register, 16 bits	UNSIGNED SHORT	Totalizer P- unit and decimals
0042-0043	2 register, 32 bits	FLOAT	Batching volume preset quantity in the unit of measure chosen. N.B: the registers returns a value only if batching is activated
0044-0045	2 register, 32 bits	FLOAT	batching volume delivered quantity in the unit of measure chosen N.B: the registers returns a value only if batching is activated
0046	1 register, 16 bits	UNSIGNED SHORT	Batching volume unit and decimals N.B: the register returns a value only if batching is activated
0047	1 register 8+8 bits	TWO BYTES	Batching process flags N.B: the register returns a value only if batching is activated

Meaning and value of the process flags 1 returned with the register 0020 (MSB):

- bit 7 (MSB): flow rate alarm MIN (flow rate below the minimum threshold set)
- bit 6: flow rate alarm MAX (flow rate over the maximum threshold set)
- bit 5: flow rate sign (1 = negative)
- bit 4: flow rate below the cut-off value
- bit 3: measure range active (0= range 1, 1= range 2)
- bit 2: flow rate measure reset value status (1= measure is forcibly reset to zero)
- bit 1: volume counters lock status (1= counters are locked)
- bit 0 (LSB): internal use, no meaning

Meaning and value of the process flags 2 returned with the register 0020 (LSB):

- bit 7 (MSB): flow rate overflow (value greater than full scale)
- bit 6: pulse channel #2 overflow (frequency greater than maximum possible for the given parameters)
- bit 5: pulse channel #1 overflow (frequency greater than maximum possible for the given parameters)
- bit 4: measure signal amplitude out of A/D converter range
- bit 3: measure signal amplitude out of amplifier capability
- bit 2: input signal error (out of input chain capability)
- bit 1: coils excitation error
- bit 0 (LSB): pipe empty

Meaning and value of the process flags 2 returned with the register 0032 (MSW):

- bits 15-03 (MSB): reserved
- bit 02: empty pipe
- bit 01: reference values not set
- bit 0 (LSB) excitation error

Meaning and value of the sensor test flags returned with the register 0032(MSW):

- bit 15 (MSB): resistance at electrode E2 is outside the limits respect to the reference value
- bit 14 : resistance at electrode E1 is outside the limits respect to the reference value
- bit 13: coil time B is outside the limits respect to the reference value
- bit 12: coil time A is outside the limits respect to the reference value
- bit 11: coil temperature is outside the limits respect to the reference value
- bit 10: coil leakage current is outside the limit
- bit 09: coil driver output 2 voltage is out of tolerance during test phase 3
- bit 08: coil driver output 1 voltage is out of tolerance during test phase 3
- bit 07: coil driver output 2 voltage is out of tolerance during test phase 2
- bit 06: coil driver output 1 voltage is out of tolerance during test phase 2
- bit 05: coil driver output 2 voltage is out of tolerance during test phase 1
- bit 04: coil driver output 1 voltage is out of tolerance during test phase 1
- bit 03: coil driver power generator voltage is out of tolerance during test phase 2
- bit 02: coil driver power generator voltage is out of tolerance during test phase 1
- bit 01: coil driver power generator value is out of tolerance during test phase 2
- bit 00 (LSB): coil driver power generator value is out of tolerance during test phase 1

Meaning and value of the measure units registers 0037, 0038, 0039, 0040, 0041, 0046:

- bit 15 (MSB) 0 = unit is metric, 1 = unit is imperial
- bit 14 0 = volume unit, 1 = weight unit
- bits 13-08 index of measure unit (unit kind depend on bits 14 and 15, see below)
- bits 07-05 reserved
- bits 04-02 decimal point position (number of digits after the decimal dot)
- bits 01-00 (LSB) time unit (for flow rate only): 0= day, 1=hour, 2=minute, 3=second

Index of metric volume units for flow rate, totalizers

- | | | |
|----|-----------------|----------------------------------|
| 00 | ml | (milliliter = 0.001 liter) |
| 01 | cm ³ | (cubic centimeter = 0.001 liter) |
| 02 | l | (liter) |
| 03 | dm ³ | (cubic decimeter = 1 liter) |
| 04 | dal | (decaliter = 10 liters) |
| 05 | hl | (hectoliter = 100 liters) |
| 06 | m ³ | (cubic meter = 1000 liters) |
| 07 | MI | (Megaliter = 1000000 liters) |

Index of imperial volume units for flow rate, totalizers and batching

00	in3	(cubic inches)
01	Gal	(US gallon)
02	IGL	(UK gallon)
03	ft3	(cubic feet)
04	bbl	(standard barrel)
05	BBL	(oil barrel)
06	hf3	(hundred cubic feet = 100 cubic feet)
07	KGL	(kilo-US gallon = 1000 US gallons)
08	IKG	(kilo-UK gallon = 1000 UK gallons)
09	kf3	(kilo-cubic feet = 1000 cubic feet)
10	ttG	(ten-thousand US gallon = 10000 US gallons)
11	Aft	(acre feet)
12	MGL	(Mega-US gallon = 1000000 US gallons)
13	IMG	(Mega-UK gallon = 1000000 UK gallons)

Index of metric weight units for flow rate, totalizers

00	g	(gram)
01	kg	(kilogram = 1000 grams)
02	t	(metric ton 0 1000000 grams)

Index of imperial weight units for flow rate, totalizers

00	oz	(ounce = 1/16 lb)
01	lb	(pound)
02	ton	(short ton)

Meaning and value of the batching process flags returned with the register 0047 (MSB):

bit 7 (MSB)	batching status: 0 = inactive (valve closed), 1 = active (valve opened)
bit 6	batching overflow error (delivered volume > 20% of set quantity)
bit 5	batching timeout error (no delivered volume for more than 4s)
bits 4-0 (LSB)	reserved

Meaning and value of the batching process flags returned with the register 0047 (LSB):

bits 7-0 reserved

ACTIVATE FUNCTIONS: FUNCTION 05

ADDRESS	SIZE	TYPE OF DATA	FUNCTION VALUE	MEANING
0000	1 REGISTER, 16 BITS	UNSIGNED SHORT	0XFF00 (HEX)	Reset the enabled totalizers (same totalizer enabled for reset from digital input).
0001	1 REGISTER, 16 BITS	UNSIGNED SHORT	0XFF00 (HEX)	enable or disable the sensor's excitation (toggle excitation status)
0002	1 REGISTER, 16 BITS	UNSIGNED SHORT	0XFF00 (HEX)	start / stop the batching process (toggle the batching status)

FUNCTION 08: DIAGNOSTICS

ADDRESS	SIZE	TYPE OF DATA	FUNCTION / VALUE
0000	1 REGISTER, 16 BITS	UNSIGNED SHORT	RETURN QUERY DATA
0001	1 REGISTER, 16 BITS	SIGNED SHORT	RESTART COMMUNICATION
0004	1 REGISTER, 16 BITS	SIGNED SHORT	ACTIVATE LISTEN MODE
0010	1 REGISTER, 16 BITS	SIGNED SHORT	CLEAR DIAGNOSTIC COUNTERS
0011	1 REGISTER, 16 BITS	UNSIGNED SHORT	NUMBER OF TOTAL RECEIVED PACKETS
0012	1 REGISTER, 16 BITS	UNSIGNED SHORT	NUMBER OF RECEIVED PACKETS WITH CRC ERROR
0013	1 REGISTER, 16 BITS	UNSIGNED SHORT	NUMBER OF RECEIVED PACKETS WITH EXCEPTION ERROR
0014	1 REGISTER, 16 BITS	UNSIGNED SHORT	NUMBER OF ADDRESSED OR BROADCAST RECEIVED PACKETS
0015	1 REGISTER, 16 BITS	UNSIGNED SHORT	NUMBER OF BROADCAST RECEIVED PACKETS
0016	1 REGISTER, 16 BITS	UNSIGNED SHORT	NUMBER OF RECEIVED PACKETS WITH NAK FLAG
0017	1 REGISTER, 16 BITS	UNSIGNED SHORT	NUMBER OF RECEIVED PACKETS WITH BUSY FLAG
0018	1 REGISTER, 16 BITS	UNSIGNED SHORT	NUMBER OF RECEIVED PACKETS WITH OVERRUN FLAG

FUNCTION 16: WRITE MULTIPLE REGISTERS

ADDRESS	SIZE	TYPE OF DATA	FUNCTION / VALUE
0000-0001	2 REGISTER, 32 BITS	FLOAT	BATCHING PRESET QUANTITY EXPRESSED IN THE CHOSEN UNIT OF MEASURE
0002-0003	2 REGISTER, 32 BITS	FLOAT	BATCHING DELIVERED QUANTITY EXPRESSED IN THE CHOSEN UNIT OF MEASURE

NOTE: registers 0000-0001 and 0002-0003 MUST be written in couples, 32 bits at time. Partial writes to a 16 bit register is NOT allowed.

FUNCTION 110: EXCHANGE MCP COMMANDS

This function permits to send MCP encapsulated commands into MODBUS packets.

Maximum allowed = 250 bytes of payload, data are NOT structured in 16-bit words as MODBUS standard, but 8-bits ascii characters strings instead.

See MCP manual for commands structure and syntax.

Reply to MCP commands sent must fit into 250 bytes packet size.



The manufacturer guarantees only English text available on our web site www.isomil.com

MANUAL REVIEWS

REVIEW	DATE	DESCRIPTION
MAN_MV110-210_MODBUS_EN_IT_IS_R00	22/06/2021	First edition



The manufacturer guarantees only English text available on our web site www.isomil.com

At the end of its lifetime, this product shall be disposed of in full compliance with the environmental regulations of the state in which it is located.

The manufacturer guarantees only English text available on our web site www.isoil.com

ISOIL INDUSTRIA S.p.A.

HEAD OFFICE	SERVICE
Via Fratelli Gracchi, 27 20092 Cinisello Balsamo (MI) Tel +39 02 66027.1 Fax +39 02 6123202 vendite@isoil.it	isomagservice@isoil.it

If you want to find the complete list of our distributors access at the following link:

<http://www.isoil.it>



Due to the constant technical development and improvement of its products, the manufacturer reserves the right to make changes and/or modify the information contained in this document without notice.