

MV110

ISOMAG



FLOMOTION
SYSTEMS

AC or DC OPERATED CONVERTER FOR ISOMAG ELECTROMAGNETIC FLOW METERS

Next generation solution for full-pipe flow measurement

The new MV110 converter is designed for applications in water, wastewater and other industrial markets where basic measurement requirements or output protocols are required.

- Accuracy: $\pm 0.4\%$ of the reading
- Repeatability: $\pm 0.2\%$
- Programmable through keypad on front panel or via PC connected through mini USB cable adapter
- Flexible mounting so that display can be seen from the top or from the front
- Galvanic separation: all inputs and outputs are separated from each other and from the power supply
- Housing material: Nylon reinforced with 15% fiberglass, or Aluminum
- Protection rating: NEMA 6 (IP 67) IP68 on request

Standard features:

- Compatible with any Isomag® flow sensor
- Low flow rate cut-off
- Bidirectional measurement
- Peak cut-off
- Empty pipe detection
- Alarm limits
- Large back-lit LCD display with protective cover

Available accessories:

- Rechargeable backup battery (assures the measurement in case of power loss)
- 4 GB data logger
- Built-in Verificator (BIV) for verifying electrical characteristics of the sensor

Available communications

- Hart or Modbus RTU protocol
- RS485 communications
- One or two 4-20mA outputs
- Two (2) pulse/frequency open collector outputs
- One (1) digital open collector input



MV110 converter with graphics display and flip-up protective cover mounted on an MS2500 flow sensor with Rilsan liner.

ELECTROMAGNETIC FLOWMETER

FLOMOTION MV110 ENGINEERING SPECIFICATIONS

- Accuracy to $\pm 0.4\%$ of rate
- Repeatability: $\pm 0.2\%$
- Ambient Temperature
 - 4 to 140°F (Aluminum Housing)
 - 4 to 104°F (Nylon Housing)
- Humidity Range: 0-100%
- Environmental Rating: NEMA 6 / IP67
- Fluid Conductivity: 5 μ S (min, compact mount)
- Power Supply Options: 12-48VDC or 100-240 VAC. 44-66Hz. 1.5w sensor only, 5w all loads.
- 4-20mA output maximum load: 1000 Ω , 24VDC.
- Inputs/outputs are galvanically isolated from power supply up to 250 V
- USB cable type A/USB MINI B required for PC programming
- Values stored in memory in case of power failure
- Graphic display 128x64 pixels w/back light
- 3 external programming keys
- Digital Outputs, 1250 Hz, 100mA, 30 Vdc (max)
- MicroSD Memory Card 4 - 32 GBytes
- Cable glands - PG11

DIMENSIONS

Compact Version

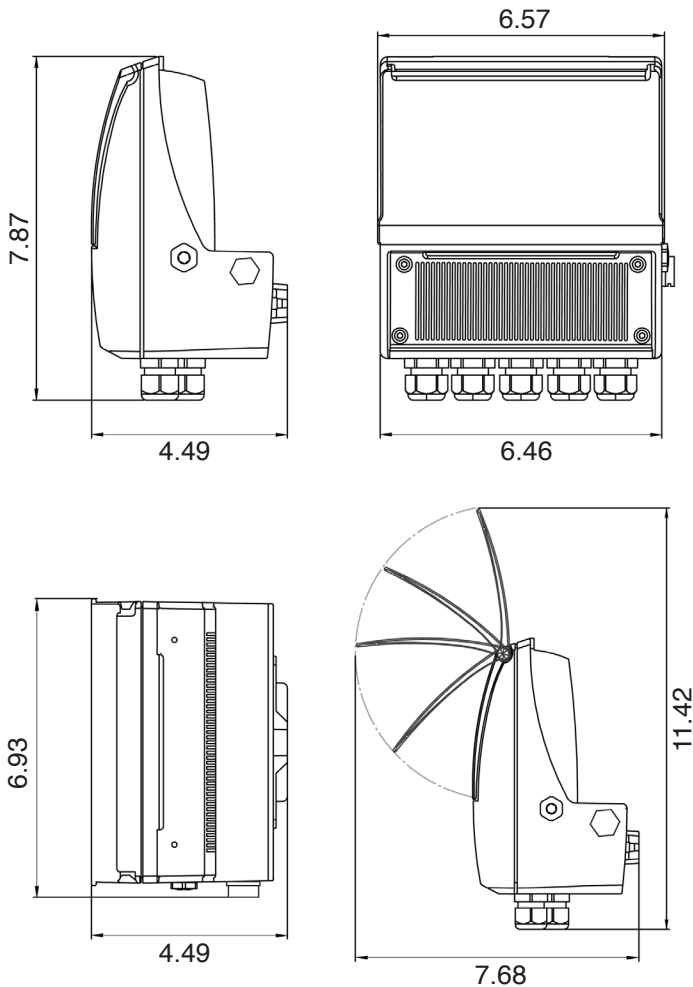

Vertical Separate Version

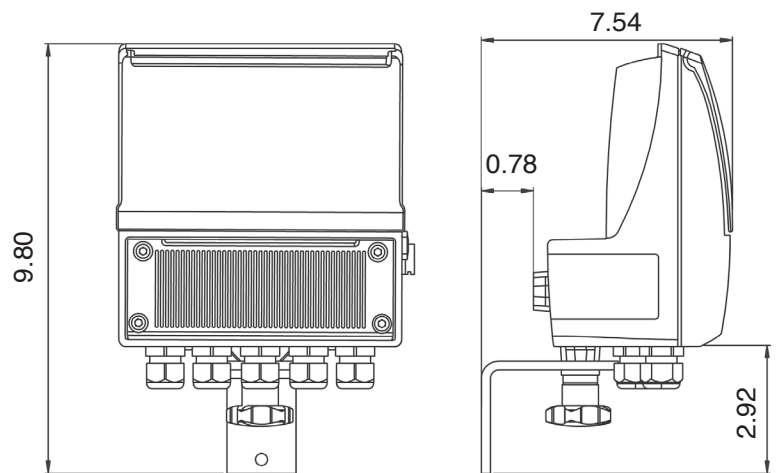

Horizontal Separate Version

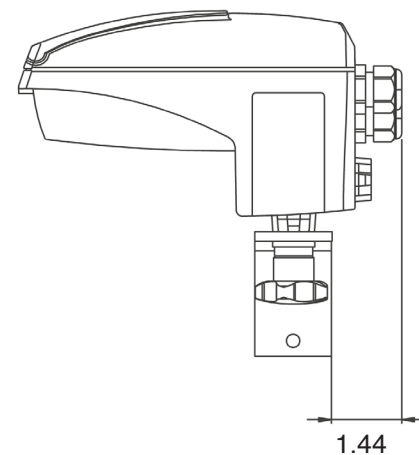

DIMENSIONS IN INCHES

FLOMOTION SYSTEMS Inc.

3 North Main St.
 Middleport, NY 14105
 Tel: 716-691-3941
 Fax: 716-691-1253
 Email: info@flomotionsystems.com
www.flomotionsystems.com

