

# MV155

ISOMAG



FLOMOTION  
SYSTEMS

## Battery powered data logger with wireless communication

**Wireless communication - Lithium or alkaline batteries - Multichannel logger  
Encrypted data - Designed for harsh environments**

The MV155 is a multi-parametric data logger with cellular connection. It can be powered by lithium or alkaline batteries or by an external power supply.

Thanks to its shape and reinforced PA6 Nylon housing, it can be installed outdoors or in aggressive environments always providing NEMA6 protection. The MV155 can be configured with different combinations of both digital and analogue inputs, monitoring different measures, and providing the power supply to the external sensors.

Thanks to the cellular connection (with DNP3 protocol as optional) it can send stored data via e-mail, SMS or via FTP folders, with easy connection to our ISOD@M monitoring system or third-party systems, always guaranteeing extremely secure transmission thanks to data encryption.

- Smart battery management
- Lithium or Alkaline batteries – external power supply available
- External sensors power supply available
- Cellular wireless communication protocol – optional DNP3 protocol
- High level of data security through encrypted transmission
- NEMA6 protection with MIL connectors: suitable for harsh environments

### Available I/O Module Options:

- Up to 4 digital inputs with flow calculation
- Up to 2 ON/OFF inputs
- Up to 2 analog inputs either for Voltage or Current
- Up to 2 analog inputs for Pressure or Temperature
- Up to 2 alarm or event digital outputs
- PA6 fiber reinforced housing
- Anti-intrusion alarm – Real time SMS alert

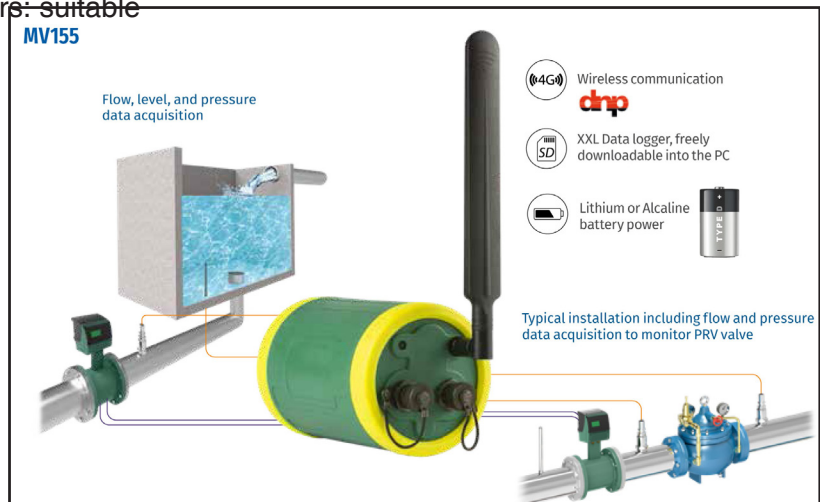
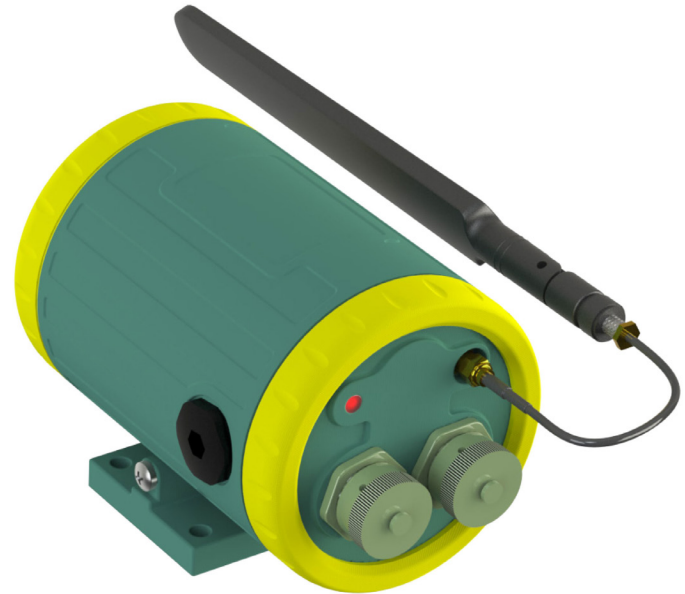

ELECTROMAGNETIC FLOWMETER

# FLOMOTION MV155 ENGINEERING SPECIFICATIONS

## OVERALL FEATURES

- Ambient Temperature: +14 to +140 °F
- Humidity Range: 0-100%

## STANDARD FEATURES

- Housing materials: Fiberglass reinforced nylon
- Protection Rate: IP 68 / NEMA 6
- Power Supply/Consumption: max 2.5 W
- Electrical Connections: MIL connectors (poles and size depend on instrument configuration)

- Data Storage: Values stored in case of power failure
- Programming Plug: USB port for the connection to PC (USB cable type A/USB MINI B)
- Communication Gateway: Cellular communication module
- Data Logger: MicroSD Memory 4 GB : Data Logger + RTC (Real Time Clock)
- Diagnostic Functions: Yes
- CE Certification: Yes

## DIMENSIONS

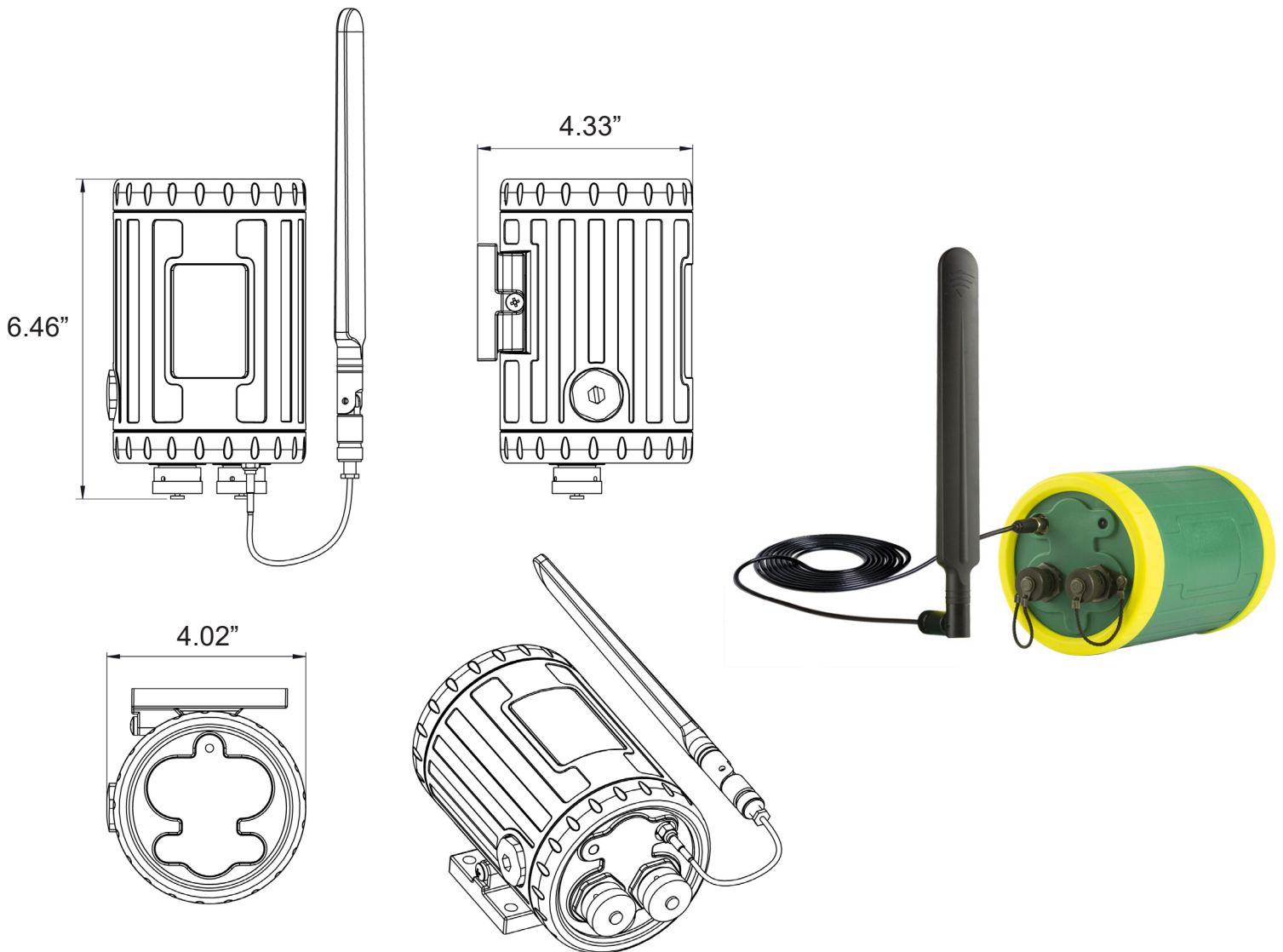

## FLOMOTION SYSTEMS Inc.

3 North Main St.

Middleport, NY 14105

Tel: 716-691-3941

Email: [info@flomotionsystems.com](mailto:info@flomotionsystems.com)

[www.flomotionsystems.com](http://www.flomotionsystems.com)

