

# BACK PRESSURE VALVES



## SIGMAMOTOR



Provides higher accuracy and safety in metering pump systems

### Back Pressure Valves

- CNC precision machined parts
- Fine pressure adjustment
- Cost effective and reliable
- Pressures from 5-150 psi (350 optional)
- Variety of materials available
- Anti-syphon protection
- Optional air release and pressure gauge port

SIGMAMOTOR Back Pressure Valves prevent siphoning and varying rates of dosage from fluctuating downstream pressure by enacting positive discharge pressure in your metering pump system. Inside the valve is a diaphragm held in place by a spring which is pressure set. When the pressure is exceeded the diaphragm is pushed up and material flows through the valve to the injection point. The valves are factory set but are easily adjusted in the field.



### Typical System

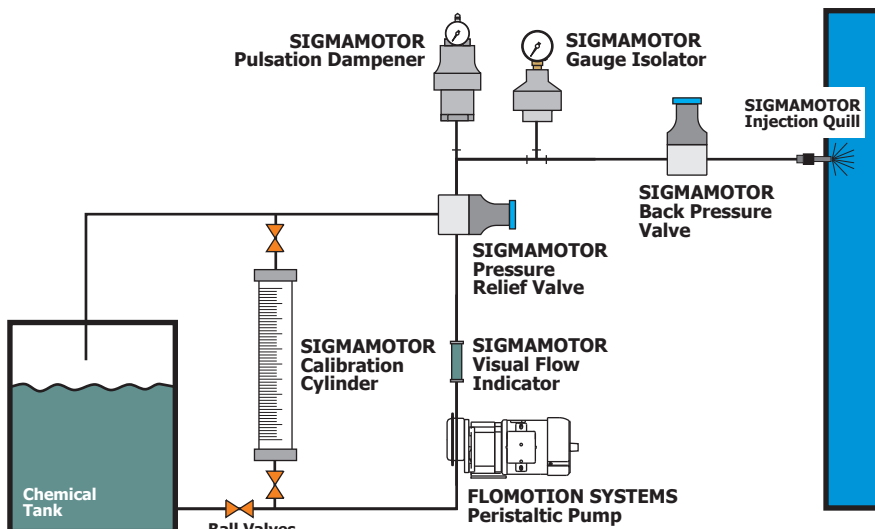

CHEMICAL FEED ACCESSORIES

**B:**        -     -     -      
           1      2      3      4

**Example: B-N-250-P-V**

**DIMENSIONS**

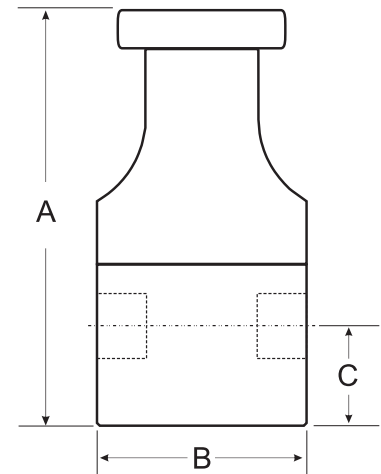

PROCESS CONNECTION TYPE <b>1</b>		
	5-150PSI SPRING WITH PVC TOP	50-350PSI SPRING WITH SS TOP*
NPT	N	MN
BSP	B	MB
SOCKET	S	MS
FLANGED	F	MF
UNION	U	MU
RIGHT ANGLE NPT	RN	RMN
RIGHT ANGLE BSP	RB	RMB
RIGHT ANGLE SOCKET	RS	RMS
RIGHT ANGLE FLANGED	RF	RMF
RIGHT ANGLE UNION	RU	RMU

\*Metal valves only

SIZE <b>2</b>								
Larger sizes upon request								
SELECT:	250	375	499	500	750	100	150	200
NPT Size (in)	1/4	3/8	1/2 (mini)	1/2 (std.)	3/4	1	1-1/2	2
A-Height (in)	Metal: 4.11    Plastic: 4.43		5.93			9.00		
B-Diameter (in)	2.34			3.45			4.00	4.45
C-Process Centerline (in)	1.07			1.18			2.05	
Pulsating US GPH	100	200	350	500	600	600	1350	2000
Continous US GPM	10	15	17.5	25	30	30	67	100

VALVE BODY with PVC Top <b>3</b>	
PVC	P
POLYPROPYLENE	PP
CPVC	CP
PTFE	T
Kynar® PVDF	K
316 SS	S
ALLOY 20	A
HASTALLOY C276	H

OPTIONS <b>4</b>	
PTFE/EPDM Diaphragm, 5-150 psi Spring & PVC Top	
VITON Diaphragm	V
EPDM Diaphragm	E
PTFE / VITON Diaphragm	TV
0-50 PSI SPRING	L
50-350 PSI SPRING	H
CPVC TOP	CP
316 SS TOP	S
PVC AIR RELEASE - EPDM	VARVE
PVC AIR RELEASE - VITON	VARVV
316 S.S. AIR RELEASE - VITON	VARVS

Material	Maximum Pressure	Maximum Temperature
PVC	150 psi	140 °F
CPVC	150 psi	195 °F
PP	150 psi	195 °F
PVDF	150 psi	285 °F
PTFE	150 psi	480 °F
METAL	350 psi	300 °F

**FLOMOTION SYSTEMS Inc.**  
 3 North Main St.  
 Middleport, NY 14105  
 Tel: 716-691-3941  
 Fax: 716-691-1253  
 Email: info@flomotionsystems.com  
 www.flomotionsystems.com

