

MINI CALIBRATION CYLINDERS

SIGMAMOTOR

Graduated Calibration Cylinders for Accurate Calibration of Chemical Metering Pumps



Verified Accuracy

SIGMAMOTOR Calibration Cylinders will enhance your feed systems by allowing verification of the flow rate of the feed pump.

- CNC precision machined ends
- Clear tube for easy GPH reading
- Sealed top
- Quick-off top for cleaning (optional)
- Loose top (optional)
- NSF-61 Approved materials

Calibration Cylinders are installed on the suction side of the metering pump. The top of the cylinder is vented back to the supply tank or drain. The calibration cylinder is filled to the top mark then the valve from the tank is closed. Turning on the metering pump will draw down the liquid providing a simple means to verify the accuracy of the pump flow rate. USGPH (Gallons Per Hour) and ML are shown on the cylinder.

SIGMAMOTOR Calibration Cylinders are critical to accurate determination of your system flow rate, either at start-up or following maintenance. Sigmamotor Calibration Cylinders are made from clear PVC with gray PVC ends.

Typical System

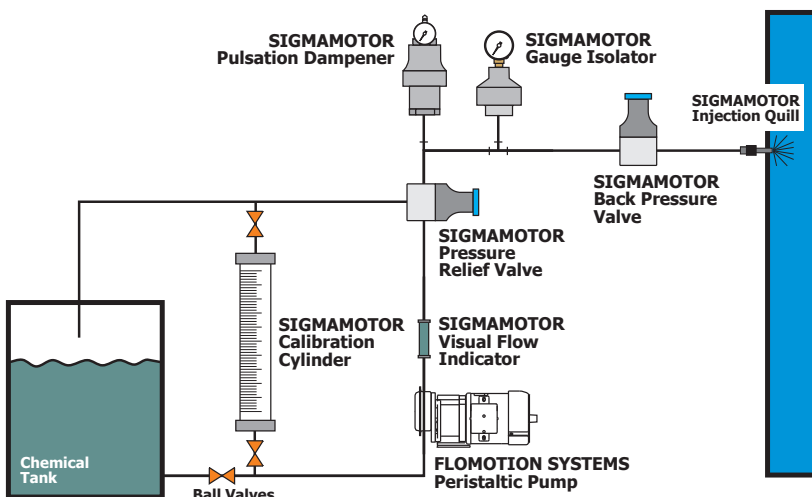

Rugged PVC Sigmamotor Calibration Cylinders are clearly marked in US GPH and milliliters for accurate drawdown calibrations.

CHEMICAL FEED ACCESSORIES

PROCESS CONNECTION TYPE 1	
NPT	N
SOCKET	S
FLANGED	F
UNION	U

CPM: - - -
 1 2 3 4

Example: CPM-N-100-Q-V

SIZE 2						
SELECT:	100	200	500	1K	2K	4K
Size (ml)	100	200	500	1000	2000	4000
A-Height (in)	5.25	8.50	7	11.25	12.5	22.2
B-Diameter (in)	2.15	2.15	3.95	3.95	4.90	4.90
C-Connection (in)	1/2	1/2	1/2	1/2	1	1
Capacity (GPH)	3.2	6.4	16	32	64	128
Scale (ml)	2	2	10	10	100	100
Scale (gph)	0.25	0.25	1	1	5	5

CAP STYLE 3	
QUICK OFF	Q
SEALED	S
LOOSE	L

O-RING MATERIAL 4	
Quick Off & Union Only	
VITON	V
EPDM	E
PTFE ENCAPSULATED	T

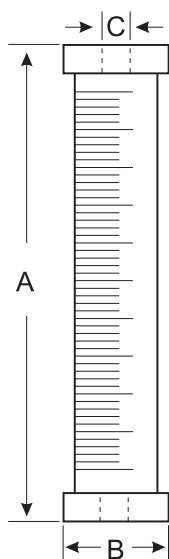

SEALED CAP (S)



Cap is permanently fixed to the top of the cylinder and includes a vent or NPT process connection. Used in applications requiring a positive suction head.

LOOSE CAP (L)



Cap is loose and easily removed for cleaning and manual filling. Used in applications where the cylinder must be filled from the top with no positive suction head.

QUICK OFF CAP (Q)



Cap is sealed with an O-ring and includes an NPT vent connection. Used in applications where frequent cleaning is required, such as polymer, alum, ferric chloride or chlorine.

Maximum Pressure:	15 psi
Maximum Temperature:	140 °F

FLOMOTION SYSTEMS Inc.
 3 North Main St.
 Middleport, NY 14105
 Tel: 716-691-3941
 Fax: 716-691-1253
 Email: info@flomotionsystems.com
 www.flomotionsystems.com

