

# MS2500

ISOMAG



FLOMOTION  
SYSTEMS

## ELECTROMAGNETIC FLOWMETERS

Reliable full-pipe flow measurement with high accuracy,  
ease of installation and low operating cost



The MS2500 is certified  
to NSF/ANSI Standard  
61 for 1" to 80" sensors.



The MS2500 is available with Rilsan, Polypropylene, Ebonite, PTFE or PFA liner with compact or remote mounted converter. Shown here with Rilsan liner and MV210 Converter.

### MS2500 FEATURES

- Accuracy to  $\pm 0.2\%$  of rate from 1 to 33 ft/sec.
- 1" to 96" Pipe Diameters
- Flow ranges from 2.4 to 179,400 GPM
- Pressures to 5600 PSI
- Volumetric flow rate measurement independent of fluid viscosity, density and temperature
- No moving parts for zero maintenance
- Bi-directional flow measurement
- No pressure drop through sensor
- Integral ground electrode
- Minimal straight pipe run required
- Every sensor is factory wet-calibrated

### TYPICAL APPLICATIONS

- Water
- Polymers
- Wastewater
- Lime Slurries
- Dyes
- Process Chemicals
- Brine
- Caustics
- Slurries
- Acids
- Starches
- Paper Stock
- Concrete



The MS2500 shown with stainless steel body, PTFE liner and junction box for remote mounted converter.

ELECTROMAGNETIC FLOWMETER

# FLOMOTION MS2500 ENGINEERING SPECIFICATIONS

- Accuracy: See relevant converter data sheet
- Repeatability:  $\pm 0.1\%$
- Temperature (max liquid temperature)
  - 4 to 158°F (-20 to 70°C) with Rilsan lining
  - 32 to 140°F (0 to 60°C) with Polypropylene lining
  - 23 to 176°F (-5 to 80°C) with Ebonite lining
  - 4 to 212°F (-20 to 100°C) with PTFE lining compact version
  - 4 to 356°F (-20 to 180°C) HT PTFE (PFA) lining remote version
- Fluid Conductivity: 5  $\mu\text{S/cm}$  (min)
- Process Connections: ANSI Flange
- Liner Material: PTFE, PFA, Ebonite, Polypropylene, Rilsan or Abreal
- Standard Pressure (ANSI 150 Flanges) Higher pressures upon request.
  - Polypropylene & Rilsan: 275psi
  - Ebonite: 928psi
  - PTFE: 580psi / PFA 232psi
- Flow Tube: 304 S.S.
- Body & Flange Material: Carbon steel with two-part epoxy coating (316 SS optional)
- Electrode Material: 316 SS, Hastelloy C, Titanium, Tantalum or Platinum
- Number of Electrodes: 3 (2 measure, 1 ground)
- Environmental Rating: NEMA 6/6P

## AVAILABLE SIZES AND DIMENSIONS (ANSI 150)

Size (in.)	1	1-1/4	1-1/2	2	3	4	6	8	10	12	14	16
Min Flow Rate (gpm @ 1 ft/sec)	2.4	3.89	6.08	9.49	24.30	37.97	85.44	151.9	237.3	341.8	465.2	607.6
Max Flow Rate (gpm @ 33 ft/sec)	77.9	127.6	199.3	311.5	797.4	1246	2803	4984	7787	11,213	15,262	19,934
Length (L below)	7.87	7.87	7.87	7.87	7.87	9.84	11.81	13.78	17.72	19.68	21.65	23.62
Height (H below)	7.13	7.28	8.15	8.74	10.20	11.34	13.43	15.79	18.15	20.75	22.91	25.16
Flange Dia. (D below)	4.24	4.57	5.00	5.98	7.52	9.02	10.98	13.50	15.98	19.02	20.98	23.50

Size (in.)	18	20	24	26	30	34	36	42	48
Min Flow Rate (gpm @ 1 ft/sec)	768.9	949.4	1367	1604	2136	2744	3076	4187	5468
Max Flow Rate (gpm @ 33 ft/sec)	25,229	31,147	44,852	52,639	70,082	90,016	100,918	137,360	179,400
Length (L below)	23.62	23.62	23.62	25.59	29.53	33.46	35.43	39.37	47.24
Height (H below)	25.16	29.57	34.09	36.26	40.63	45.24	47.48	54.37	58.66
Flange Dia. (D below)	23.50	27.52	32.01	34.25	38.74	43.74	45.98	52.99	57.28

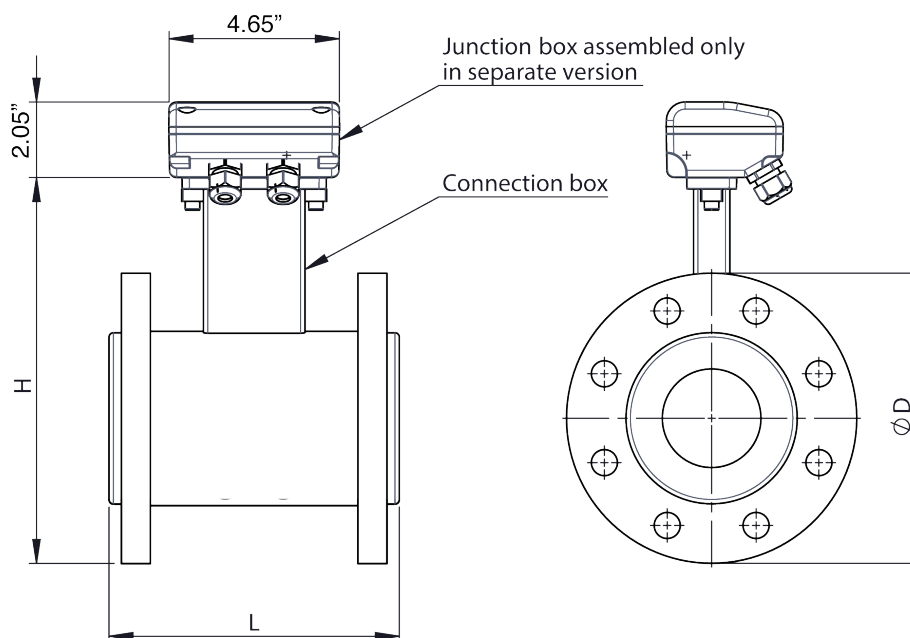

### FLOMOTION SYSTEMS Inc.

3 North Main St.  
 Middleport, NY 14105  
 Tel: 716-691-3941  
 Fax: 716-691-1253  
 Email: [info@flomotionsystems.com](mailto:info@flomotionsystems.com)  
[www.flomotionsystems.com](http://www.flomotionsystems.com)

