

Quick Start Manual



Read the user's manual carefully before starting to use the unit.
Producer reserves the right to implement changes without prior notice.

Safety Information

- De-pressurize and vent system prior to installation or removal
- Confirm chemical compatibility before use
- **DO NOT** exceed maximum temperature or pressure specifications
- **ALWAYS** wear safety goggles or face-shield during installation and/or service
- **DO NOT** alter product construction



Warning | Caution | Danger

Indicates a potential hazard. Failure to follow all warnings may lead to equipment damage, injury, or death.



Hand Tighten Only

Over tightening may permanently damage product threads and lead to failure of the retaining nut.



Note | Technical Notes

Highlights additional information or detailed procedure.



Do Not Use Tools

Use of tool(s) may damage product beyond repair and potentially void product warranty.



Personal Protective Equipment (PPE)

Always utilize the most appropriate PPE during installation and service of Truflo products.



Pressurized System Warning

Sensor may be under pressure. Take caution to vent system prior to installation or removal. Failure to do so may result in equipment damage and/or serious injury.

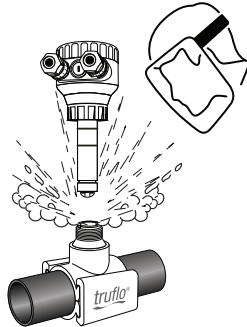

General Information

General	Description
Operating Voltage	10 – 30VDC
Current Consumption	60mA max.
Control Output	NPN 150mA max.
Transmitter	4-20mA
Communication	RS485*
Flow Rate GPM LPM	0.0 – 999.9
Fluid	H2O Liquid Chemical Media
Accuracy	± 0.5% of F.S. @25°C
Response Frequency	5K Hz
Max Flow Rate	10m/s 33ft/s
Min Flow Rate	0.1m/s 0.3ft/s
Materials of Construction	Rotor: ETFE Tefzel® Rotor Pin: Zirconium Ceramic Rotor Bushings: Ceramic Sensor Body: PVC/PP/PVDF/316SS
O-ring material	FPM EPDM Optional FFKM Optional
Operating Temperature	PVC < 60°C PP < 80°C PF < 100°C
Protection Rating	NEMA 4X IP66 General Purpose
Approval	CE RoHS

*Optional

Industry's Most Accurate & Reliable Paddle Wheel Flow Meters

The TI Series insertion plastic paddle wheel flow meter has been engineered to provide long-term accurate flow measurement in tough industrial applications.

The paddle wheel assembly consists of an engineered Tefzel® paddle and micro-polished zirconium ceramic rotor pin and bushings.

High performance Tefzel® and Zirconium materials have been selected due to their excellent chemical and wear resistant properties.

- ✓ ½" – 24" Line Sizes
- ✓ Flow Rate | Total
- ✓ Pulse | 4 – 20mA | Voltage Outputs

New ShearPro® Design

- ✓ Contoured Flow Profile
- ✓ Reduced Turbulence = Increased Longevity
- ✓ 78% Less Drag than Old Flat Paddle Design*

*Ref: NASA "Shape Effects on Drag"

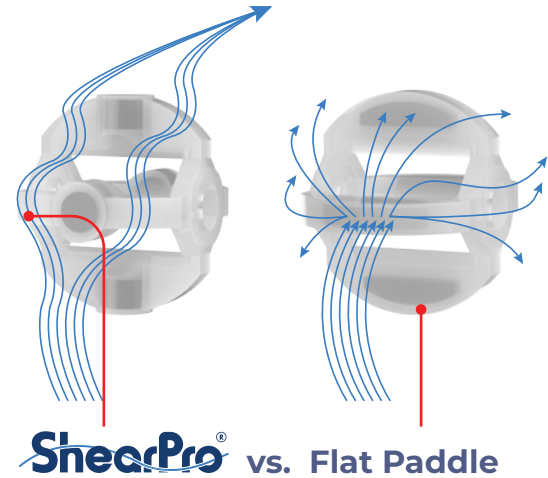

Tefzel® Paddle Wheel

- ✓ Superior Chemical And Wear Resistance vs PVDF

Zirconium Ceramic Rotor | Bushings

- ✓ Up to 15x the Wear Resistance
- ✓ Integral Rotor Bushings Reduce Wear and Fatigue Stress

360° Shielded Rotor Design

- ✓ Eliminates Finger Spread
- ✓ No Lost Paddles

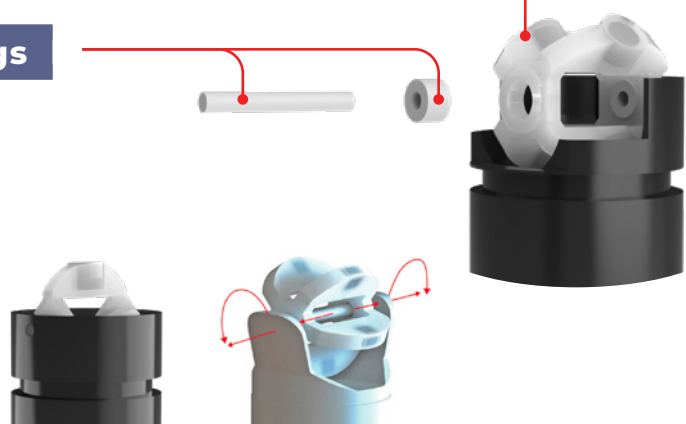

ShearPro® vs. Competitor

TIP Series

Multi-Function Paddle Wheel Flow Meter



Installation

Very Important



- Lubricate O-rings with a viscous lubricant, compatible with the materials of construction.
- Using an alternating | twisting motion, carefully lower the sensor into the fitting. | **Do Not Force** | Fig 5
- Ensure tab | notch are parallel to flow direction | Fig-2



Hand tighten the sensor cap. **DO NOT** use any tools on the sensor cap or the cap threads or fitting threads may be damaged. | Fig-5

Fig - 1

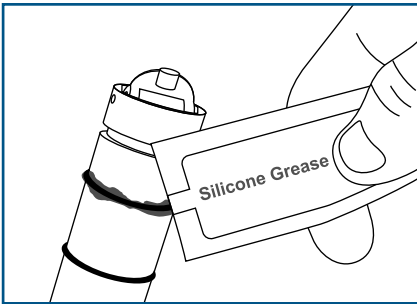
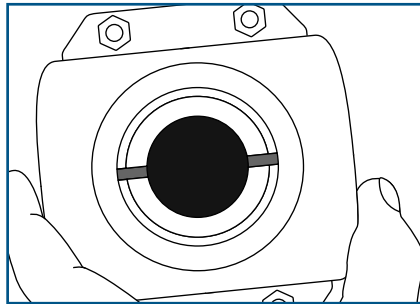
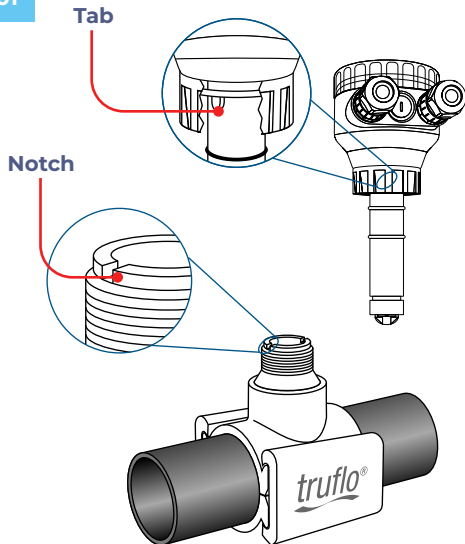

Fig - 2



Correct Sensor Position

01



Locate the flow meter positioning tab and clamp saddle notch.

02

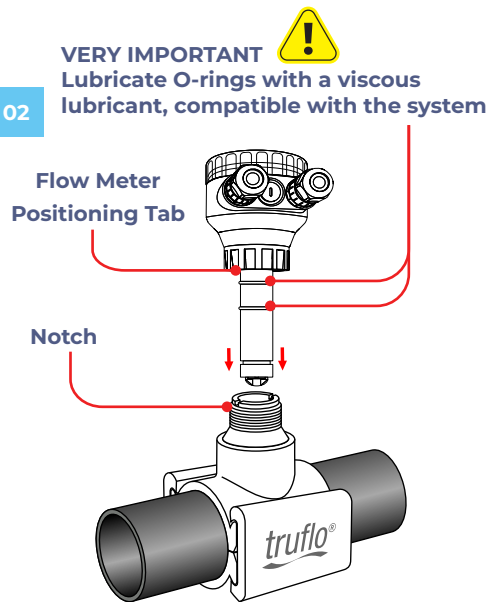

Engage one thread of the sensor cap, then turn the sensor until the alignment tab is seated in the fitting notch. Ensure tab is parallel to flow direction.

03

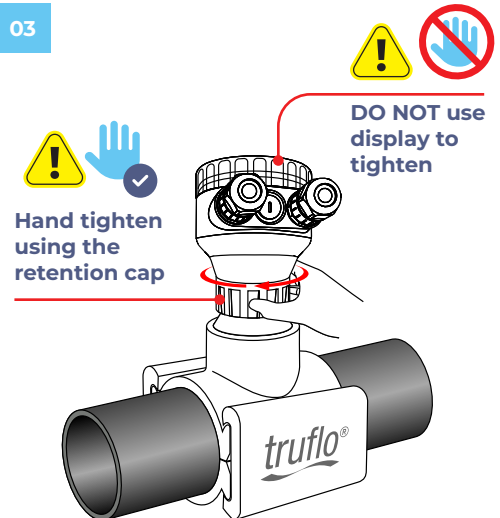

Hand tighten using the retention cap

- Hand tighten the screw cap
- **DO NOT** use any tools — threads may be damaged
- Ensure meter is firmly in place

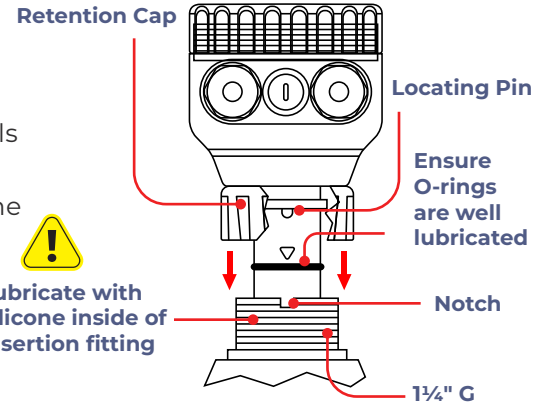

Fig - 3

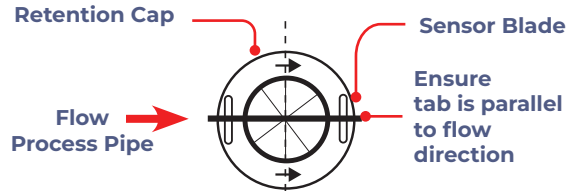

Fig - 4

Top View

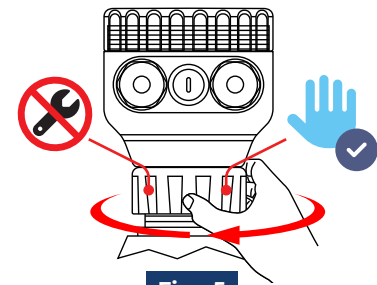

Fig - 5

TIP Series

Multi-Function Paddle Wheel Flow Meter



Correct Sensor Position Setup

TI Series flow meters measure liquid media only. There should be no air bubbles and the pipe must always remain full. To ensure accurate flow measurement, the placement of the flow meters needs to adhere to specific parameters. This requires a straight run pipe with a minimum number of pipe diameters distance upstream and downstream of the flow sensor.

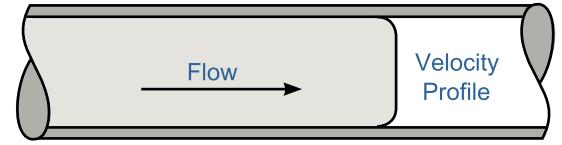

Developed Turbulent Flow

Flange

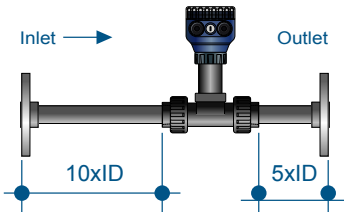

2x 90° Elbow

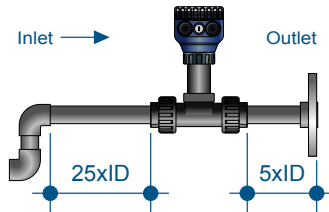

Reducer

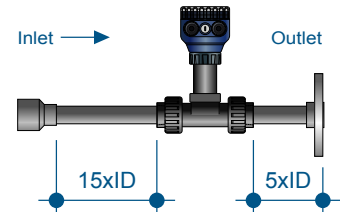

90° Downward Flow

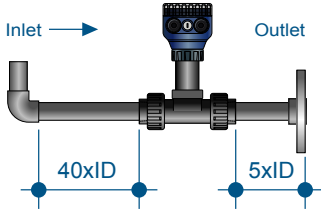

90° Elbow Downward Flow Upward

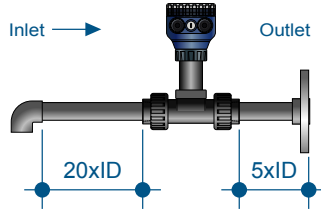

Ball Valve

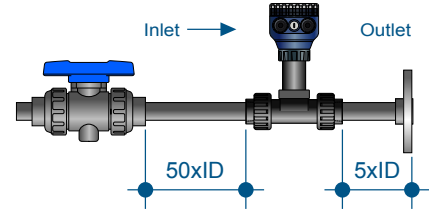

Installation Positions

Figure - 1

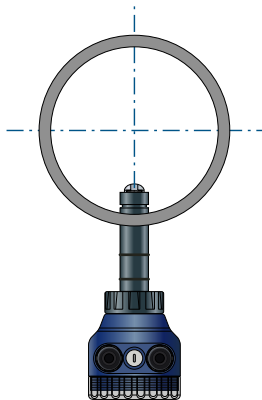

Good if NO SEDIMENT present

Figure - 2

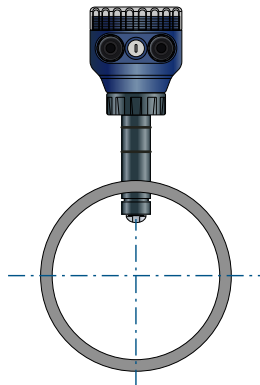

Good if NO AIR BUBBLES present

Figure - 3

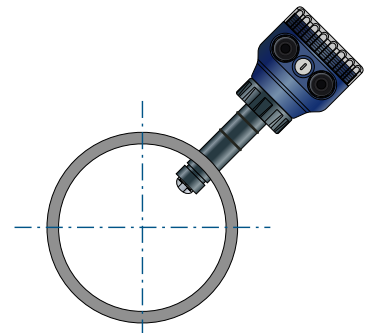

Preferred installation if SEDIMENT* or AIR BUBBLES may be present

*Maximum % of solids: 10% with particle size not exceeding 0.5mm cross section or length

TIP Series

Multi-Function Paddle Wheel Flow Meter



Terminal Connections



Cable Grip Wire Connector Combo
(no Internal wiring required)

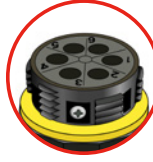

Cable Grip Connection

Terminal	Description
1	+ 10-30VDC
2	OUT 2 (NPN)
3	- VDC
4	OUT 1 (NPN)
5	RS-485 -
6	RS-485 +



M12 Connection (no Internal wiring required)

Terminal	Description	Color
1	+ 10-30 VDC	Brown
2	Totalizer Pulse Output NPN	White
3	- VDC	Blue
4	Flow Rate Pulse Output NPN	Black
5	RS-485 +	Yellow
6	RS-485 -	Grey

Fittings and K-Factor

TEE FITTINGS

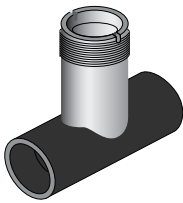

Tee Fitting		K-Factor		Sensor Length
IN	DN	LPM	GPM	
¾"	20	160.0	604.0	S
1"	25	108.0	408.0	S
1½"	40	37.0	140.0	S
2"	50	21.6	81.7	L
2½"	65	14.4	54.4	L
3"	80	9.3	35.0	L
4"	100	5.2	19.8	L

CLAMP-ON SADDLES

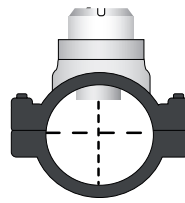

Clamp Saddles		K-Factor		Sensor Length
IN	DN	LPM	GPM	
2"	50	21.6	81.7	S
3"	80	9.3	35.0	S
4"	100	5.2	19.8	S
6"	150	2.4	9.2	L
8"	200	1.4	5.2	L

CPVC SOCKET WELD-ON ADAPTERS

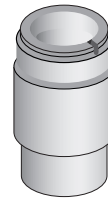

Weld On Adapter		K-Factor		Sensor Length
IN	DN	LPM	GPM	
2"	50	14.4	54.4	S
2½"	65	9.3	35.5	S
3"	80	9.3	35.0	S
4"	100	5.2	19.8	S
6"	150	2.4	9.2	L
8"	200	1.4	5.2	L
10"	250	0.91	3.4	L
12"	300	0.65	2.5	L
14"	400	0.5	1.8	L
16"	500	0.4	1.4	L
18"	600	0.3	1.1	L
20"	800	0.23	0.9	L
24"	1000	0.16	0.6	L

Pressure vs. Temperature

Note: During system design the specifications of all components must be considered. | Non-Shock

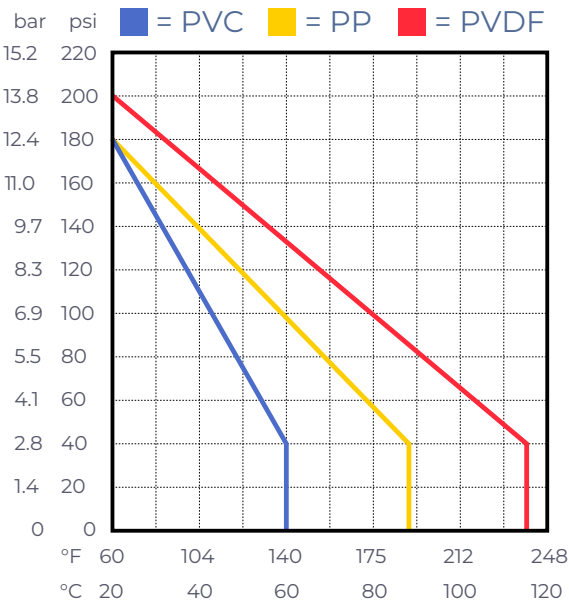

Min/Max Flow Rates

Pipe Size (O.D.)	LPM GPM	
	0.3m/s min.	10m/s max
½" DN15	3.5 1.0	120.0 32.0
¾" DN20	5.0 1.5	170.0 45.0
1" DN25	9.0 2.5	300.0 79.0
1 ½" DN40	25.0 6.5	850.0 225.0
2" DN50	40.0 10.5	1350.0 357.0
2 ½" DN60	60.0 16.0	1850.0 357.0
3" DN80	90.0 24.0	2800.0 739.0
4" DN100	125.0 33.0	4350.0 1149.0
6" DN150	230.0 60.0	7590.0 1997.0
8" DN200	315.0 82.0	10395.0 2735.0

TIP Series

Multi-Function Paddle Wheel Flow Meter



Programming



Select/Save/Continue



Move selection left



Change digit value

STEPS	DISPLAY	OPERATION
1 Press and Hold SET 		Home Screen
2 Password 		Factory Default: Lk = 10 Otherwise meter will enter Lockout Mode* Press / to change Press to save
3 Units of Flow 		Ut.G = Gallons (Factory default) Ut.L = Liters Ut.KL = Kiloliters Press to change Press to save
4 K Factor 		Enter K Factor Value Refer to Page 6 for K-Factor Values
5 Transmitter Range 		Factory Default — 4mA = 0, 20mA = 100** **This can be change to suit application

Programming Frequency Pulse Relay Output

STEPS	DISPLAY	OPERATION
1 Press and Hold SET 		Home Screen
2 Flow Rate Pulse Output 		CV - Program Value of (Flow Rate) Pulse (NPN) Output Preset Value of Flow Rate Change to a Value that meets your Flow Rate Pulse Output SV - CV > SV ► Flow Rate Pulse Output ON CV < SV ► Flow Rate Pulse Output OFF
3 Flow Total Pulse Output 		CV - Program Value of Flow Totalizer Pulse (NPN) Output SV: Preset Value of Flow Total SV - CV > SV ► Flow Rate Pulse Output ON 2000 Default can be changed to desired value. Refer to "Programming OP2 Output" for totalizer options Flow Totalizer Pulse - (Step #2 - Next)

Programming Relay Output

STEPS	DISPLAY	OPERATION
1 Press and Hold SET SET + 3 SEC		Home Screen
2 OP2 Output Pulse Control (Frequency) SET		Con = n: OP2 Manual Reset; Con = c: time (1=10 Secs) Auto Reset Using Timer time (Secs) Auto Reset Using Timer i.e. 5 = Pulse on (5 Secs) Con = r: Auto Reset when Total Volume Value = Select Value (SV) Con = E: Pulse Output of Unit volume (Default) = One Gal/Pulse Con = F → Paddle Pulse → Frequency Max 5 KHz (For TVF)
3 Pulse Relay SET		Refer to Relay Selection Mode Below
4 Hysteresis SET		Press to change Press SET to save (Hysteresis is a buffer around the programmed set point)
5 Time Delay SET		

Relay Option Outputs

ALt No.	Description
Alt = 0	CV > SV → ON: CV < SV - Hys → OFF 'Normally Closed Relay'
Alt = 1	CV < SV → ON: CV > SV + Hys → OFF 'Normally Open Relay'
Alt = 2	SV + Hys > CV > SV - Hys → ON: CV > SV + Hys or CV < SV - Hys → OFF
Alt = 3	SV + Hys > CV > SV - Hys → OFF: CV > SV + Hys or CV < SV - Hys → ON
Hys = Hysteresis — Acts like a buffer ± around pulse output (measured in GPM)	
CV: Current Value = Flow Rate SV = Selected or Programmed Value	

Rotor Pin | Paddle Replacement

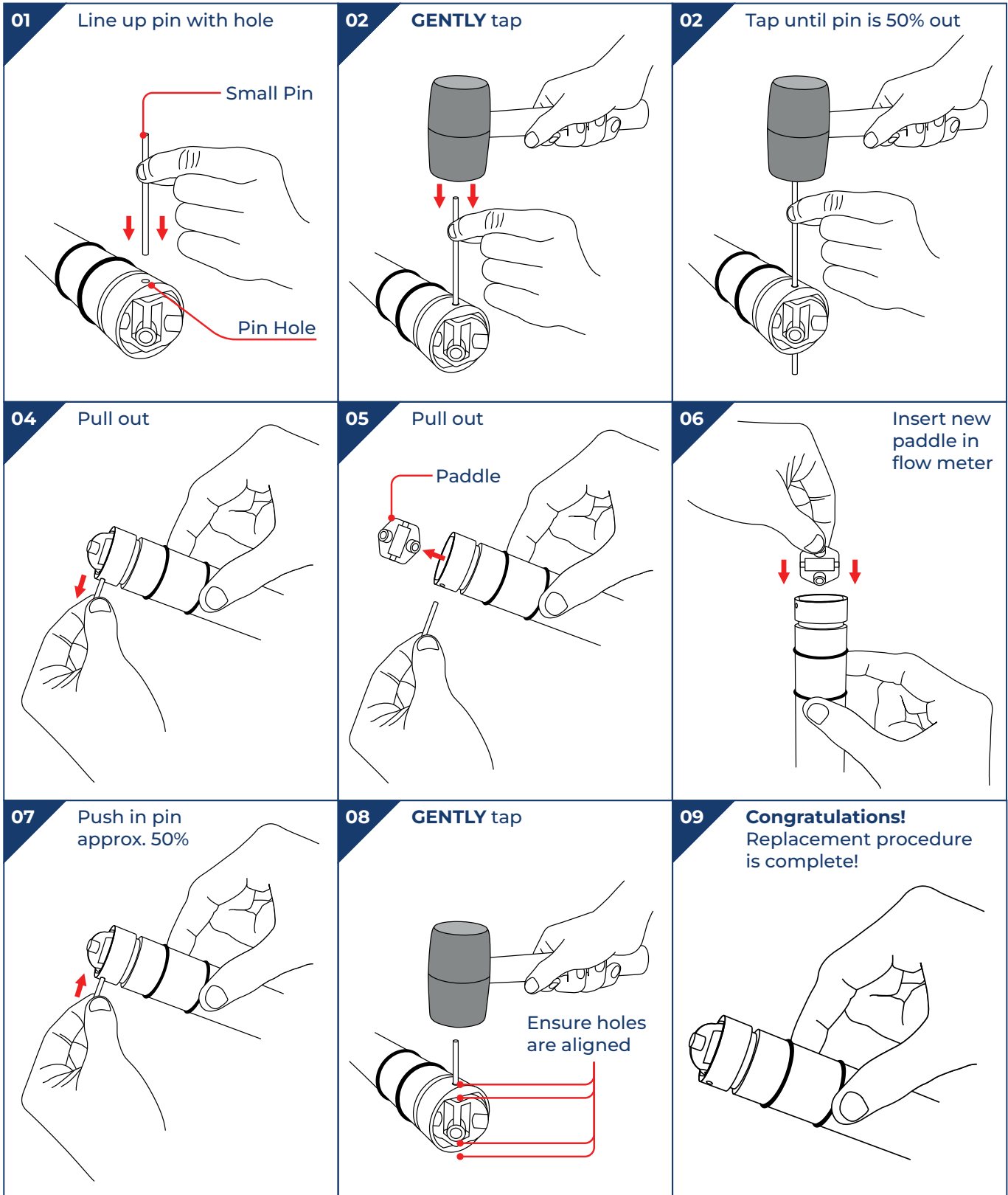

Warranty, Returns and Limitations

Warranty

Icon Process Controls Ltd warrants to the original purchaser of its products that such products will be free from defects in material and workmanship under normal use and service in accordance with instructions furnished by **Icon Process Controls Ltd** for a period of one year from the date of sale of such products. **Icon Process Controls Ltd** obligation under this warranty is solely and exclusively limited to the repair or replacement, at **Icon Process Controls Ltd** option, of the products or components, which **Icon Process Controls Ltd** examination determines to its satisfaction to be defective in material or workmanship within the warranty period. **Icon Process Controls Ltd** must be notified pursuant to the instructions below of any claim under this warranty within thirty (30) days of any claimed lack of conformity of the product. Any product repaired under this warranty will be warranted only for the remainder of the original warranty period. Any product provided as a replacement under this warranty will be warranted for the one year from the date of replacement.

Returns

Products cannot be returned to **Icon Process Controls Ltd** without prior authorization. To return a product that is thought to be defective, go to www.iconprocon.com, and submit a customer return (MRA) request form and follow the instructions therein. All warranty and non-warranty product returns to **Icon Process Controls Ltd** must be shipped prepaid and insured. **Icon Process Controls Ltd** will not be responsible for any products lost or damaged in shipment.

Limitations

This warranty does not apply to products which: 1) are beyond the warranty period or are products for which the original purchaser does not follow the warranty procedures outlined above; 2) have been subjected to electrical, mechanical or chemical damage due to improper, accidental or negligent use; 3) have been modified or altered; 4) anyone other than service personnel authorized by **Icon Process Controls Ltd** have attempted to repair; 5) have been involved in accidents or natural disasters; or 6) are damaged during return shipment to **Icon Process Controls Ltd** reserves the right to unilaterally waive this warranty and dispose of any product returned to **Icon Process Controls Ltd** where: 1) there is evidence of a potentially hazardous material present with the product; or 2) the product has remained unclaimed at **Icon Process Controls Ltd** for more than 30 days after **Icon Process Controls Ltd** has dutifully requested disposition. This warranty contains the sole express warranty made by **Icon Process Controls Ltd** in connection with its products. **ALL IMPLIED WARRANTIES, INCLUDING WITHOUT LIMITATION, THE WARRANTIES OF MERCHANTABILITY AND FITNESS FOR A PARTICULAR PURPOSE, ARE EXPRESSLY DISCLAIMED.** The remedies of repair or replacement as stated above are the exclusive remedies for the breach of this warranty. **IN NO EVENT SHALL Icon Process Controls Ltd BE LIABLE FOR ANY INCIDENTAL OR CONSEQUENTIAL DAMAGES OF ANY KIND INCLUDING PERSONAL OR REAL PROPERTY OR FOR INJURY TO ANY PERSON. THIS WARRANTY CONSTITUTES THE FINAL, COMPLETE AND EXCLUSIVE STATEMENT OF WARRANTY TERMS AND NO PERSON IS AUTHORIZED TO MAKE ANY OTHER WARRANTIES OR REPRESENTATIONS ON BEHALF OF Icon Process Controls Ltd.** This warranty will be interpreted pursuant to the laws of the province of Ontario, Canada.

If any portion of this warranty is held to be invalid or unenforceable for any reason, such finding will not invalidate any other provision of this warranty.

For additional product documentation and technical support visit:

www.iconprocon.com | e-mail: sales@iconprocon.com or support@iconprocon.com | Ph: 905.469.9283