

# Quick Start Manual



### Symbol Explanation



This symbol denotes especially important guidelines concerning the installation and operation of the device. Not complying with the guidelines denoted by this symbol may cause an accident, damage or equipment destruction.

### Basic Requirements | User Safety



- Do not use the unit in areas threatened with excessive shocks, vibrations, dust, humidity, corrosive gasses and oils.
- Do not use the unit in areas where there is risk of explosions.
- Do not use the unit in areas with significant temperature variations, exposure to condensation or ice.
- The manufacturer is not responsible for any damages caused by inappropriate installation, not maintaining the proper environmental conditions and using the unit contrary to its assignment.
- If in the case of a unit malfunction there is a risk of a serious threat to the safety of people or property additional, independent systems and solutions to prevent such a threat must be used.
- The unit uses dangerous voltage that can cause a lethal accident. The unit must be switched off and disconnected from the power supply prior to starting installation of troubleshooting (in the case of malfunction).
- Do not attempt to disassemble, repair or modify the unit yourself. The unit has no user serviceable parts.
- Defective units must be disconnected and submitted for repairs at an authorized service center.

### Specifications

General	
Display	LED   6 Digit   13mm High   Red   Adjustable Brightness
Displayed Values	0 ~ 999999
RS485 Transmission	1200...115200 bit/s, 8N1 / 8N2
Housing Material	Polycarbonate
Protection Class	NEMA 4X   IP67
Input Signal   Supply	
Standard	Current: 4-20mA   0-20mA   0-5V*   0-10V*
Voltage	85 - 260V AC/DC   16 - 35V AC, 19 - 50V DC*
Output Signal   Supply	
Standard	2 x Relays (5A)   1 x Relay (5A) + 4-20mA
Communication	RS485
Voltage	24VDC
Passive current output *	4-20mA   (Operating Range Max. 2.8 - 24mA)
Performance	
Accuracy	0.1% @ 25°C One Digit
Temperatures	
Operating Temperature	-40 - 158°F   -40 - 70°C

\*Optional

### Front Panel Description



### Function of Push Buttons



#### Symbol used in the manual : [ESC/MENU]

##### Functions:

- Enter to main menu (press and hold for at least 3 sec.)
- Exit the current Screen and Enter to previous menu (or measure mode)
- Cancel the changes made in parameter being edited



#### Symbol used in the manual : [ENTER/PAUSE]

##### Functions:

- Start to edit the parameter
- Enter into the sub-menu
- Confirmation of changes made in parameter being edited
- While batcher mode : Pause / Start Batching



#### Symbol used in the manual : [Σ/RESET]

##### Functions:

- Switching of the display between total and instantaneous measurements or batcher counter (while batcher mode only)
- Zeroing the currently displayed counter (Press & Hold for at least 2 Sec), the zeroing must be confirmed by [ENTER] button



#### Symbol used in the manual : [^] [v]

##### Functions:

- Change of the present menu
- Modification of the parameter value
- Switching of the display between relay thresholds and number of batches counter.

### Dimensions

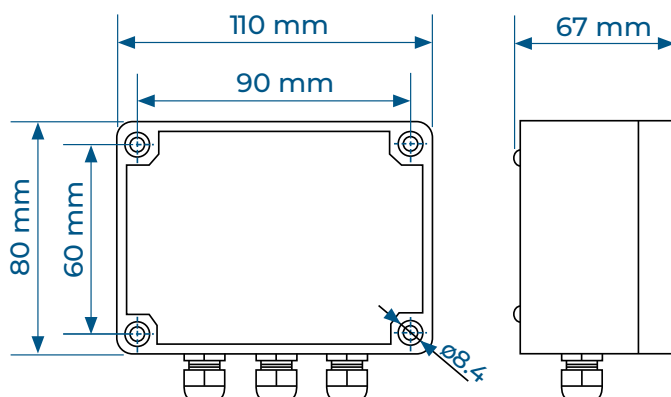

### Wiring Diagram

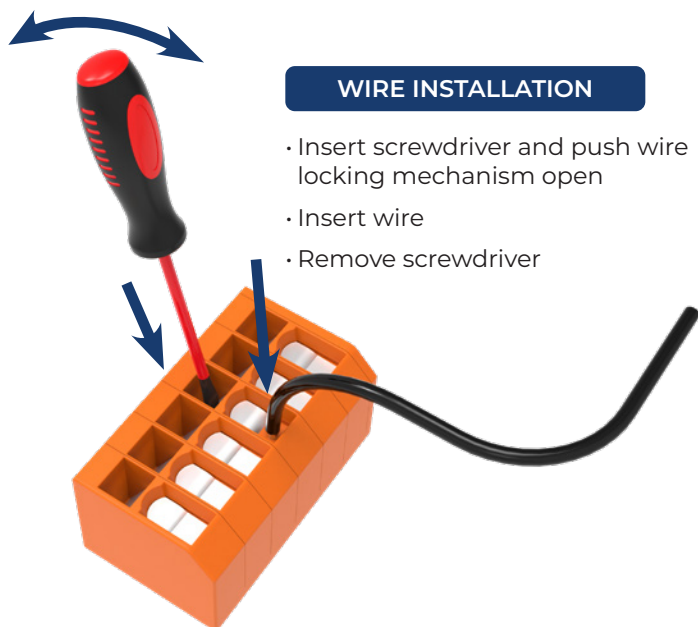
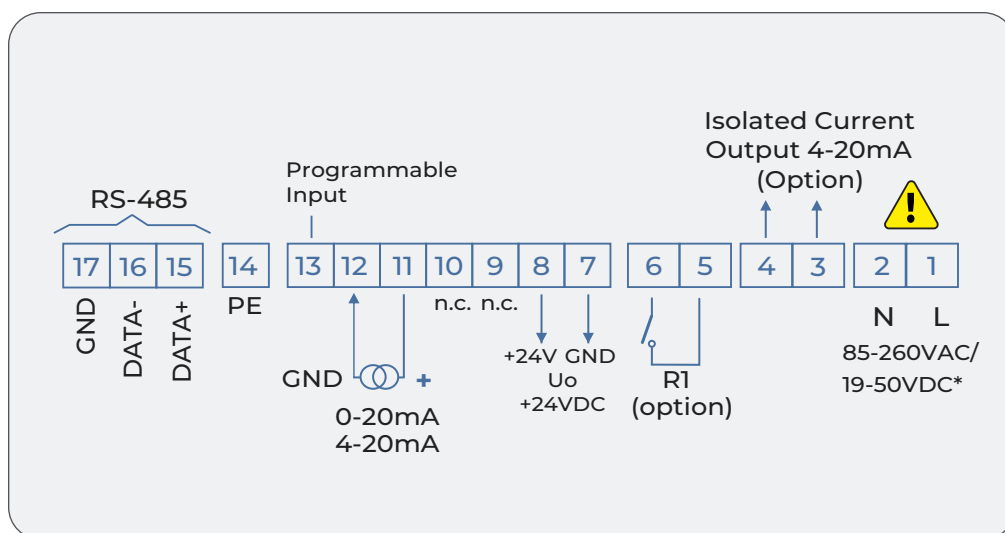

#### WIRE INSTALLATION

- Insert screwdriver and push wire locking mechanism open
- Insert wire
- Remove screwdriver



**Due to possible significant interference in industrial installations, appropriate measures assuring correct operation of the unit must be applied.**

The unit is not equipped with an internal fuse or power supply circuit breaker. For this reason, an external time-delay cut-out fuse with a small nominal current value must be used (recommended bipolar, max. 2A) and a power supply circuit breaker located near the unit.

### Power Supply & Relay Connection

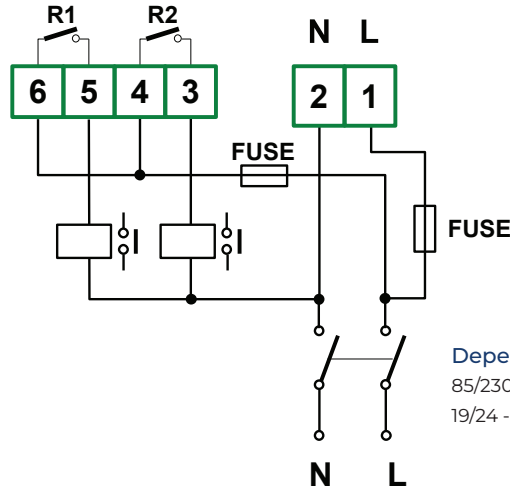

Depending on Version  
85/230/260V AC/DC ; 50 - 60 Hz  
19/24 - 50V DC ; 16/24/35V AC



Contacts of relay outputs are not equipped with spark suppressors. When using the relay outputs for switching of inductive loads (coils, contactors, power relays, electromagnets, motors etc.) it is required to use additional suppression circuit (typically capacitor 47nF/ min. 250VAC in series with 100R/5W resistor), connected in parallel to relay terminals or (better) directly on the load.

### Suppression Circuit Connection

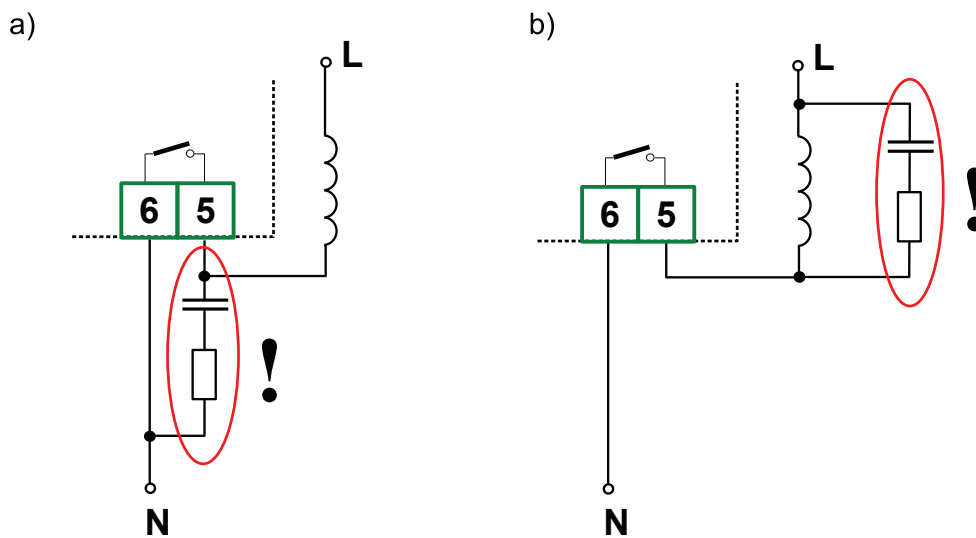

Figure: Examples of Suppression Circuit Connection  
a) To Stepper Relay Terminals b) To the Inductive Load (Motor)

### OC-Type Output Connection

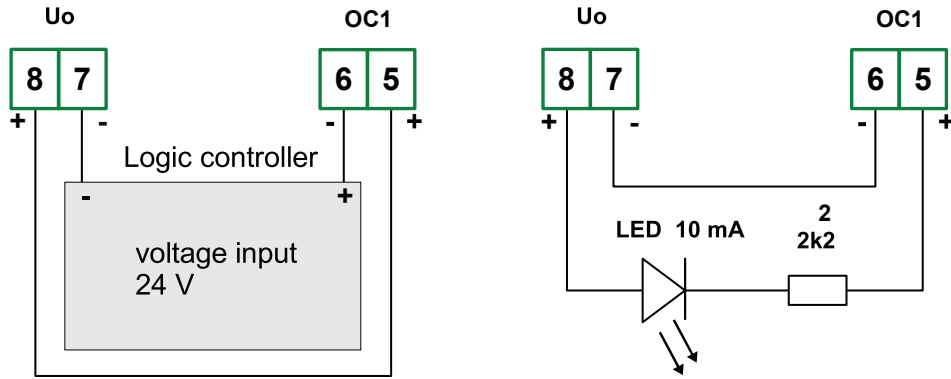

Figure: Examples of OC-type output connection

### Current Output Connection Using Internal Power Supply

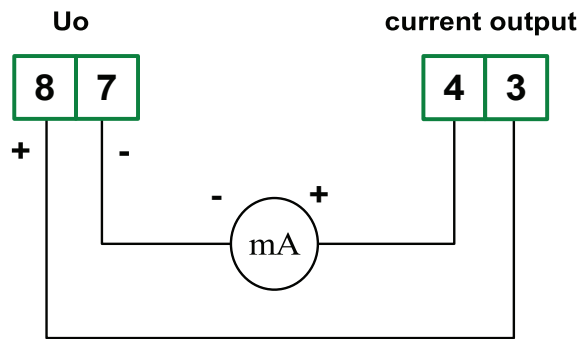

Figure: Example of current output connection using internal power supply

### Current Output Connection Using External Power Supply

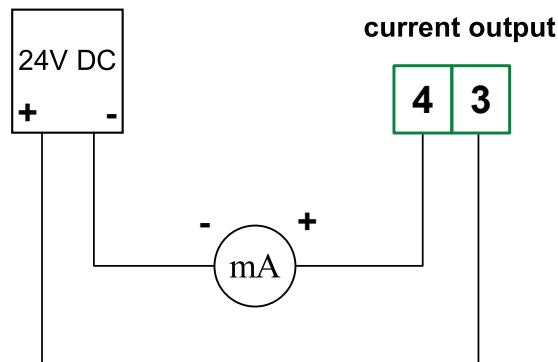
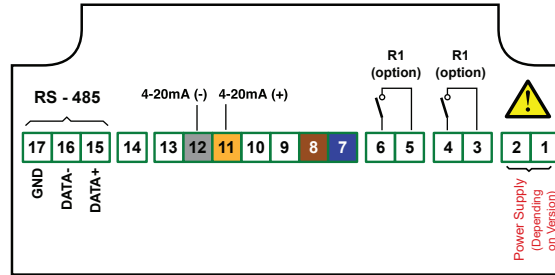

Figure: Example of current output connection using external power supply

### Flow Meter Connections (Relay Type)

#### TKM Series : 4-20mA Output

TVF Terminal	Wire Color	Description
7	Blue	-VDC
8	Brown	+VDC
11	Yellow	mA+
12	Grey	mA-



#### TKS Series : Pulse Output

GPM/Pulse = K factor

TVF Terminal	Wire Color	Description
7	Blue	-VDC
8	Brown	+VDC
10	Black	NPN Pulse
Jump 13 & 8		

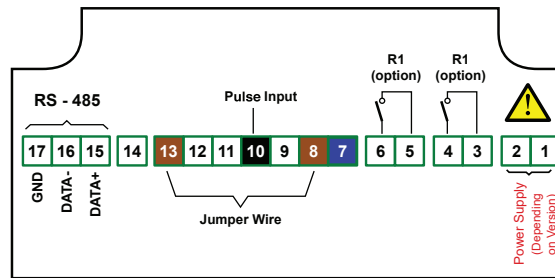

#### TKW Series : Pulse Output

GPM/Pulse = K factor

TVF Terminal	Wire Color	Description
7	Blue	-VDC
8	Brown	+VDC
10	Black	Pulse
Jump 13 & 8		

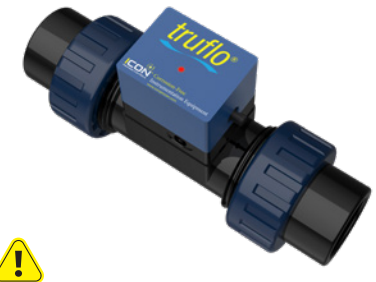
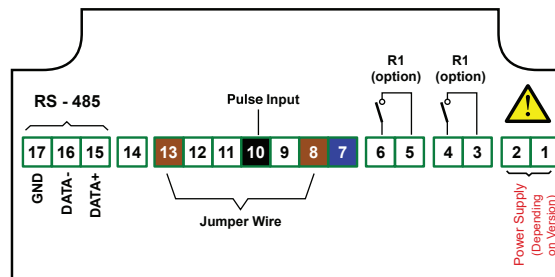

#### TKW Series : 4-20mA Output

TVF Terminal	Wire Color	Description
7	Blue	-VDC
8	Brown	+VDC
11	Black	mA+
12	White	mA-

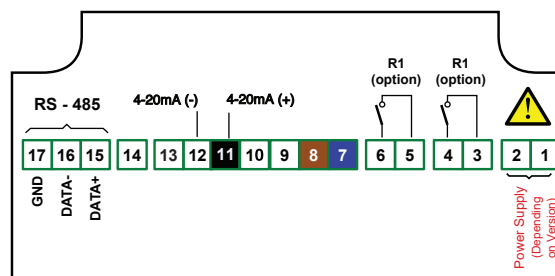

# LevelPro® — TVF Series

## Flow Display | Controller | Batcher

TKM   TKP Series : Pulse Output		
GPM/Pulse = K factor		
TVF Terminal	Wire Color	Description
7	Blue	-VDC
8	Brown	+VDC
10	Black	Pulse
Jump 13 & 8		

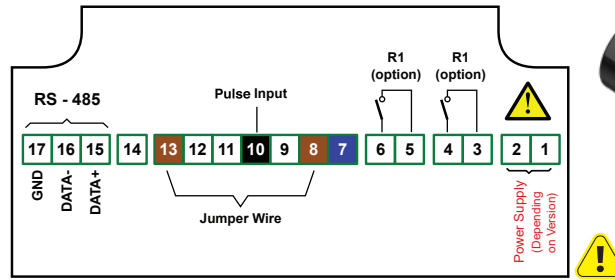

TIW Series : Pulse Output		
GPM/Pulse = K factor		
TVF Terminal	Wire Color	Description
7	Blue	-VDC
8	Brown	+VDC
10	White	Pulse
Jump 13 & 8		

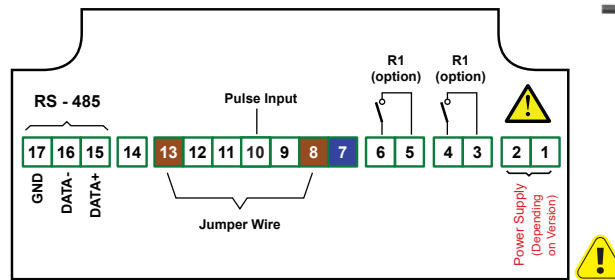

TIM   TIP Series : Pulse Output		
GPM/Pulse = K factor		
TVF Terminal	Wire Color	Description
7	Blue	-VDC
8	Brown	+VDC
10	White	Pulse
Jump 13 & 8		

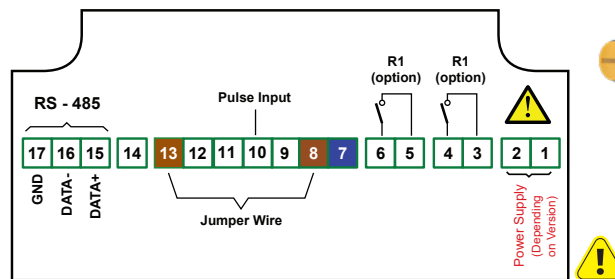

TIM Series : 4-20mA Output		
TVF Terminal	Wire Color	Description
7	Blue	-VDC
8	Brown	+VDC
11	Yellow	mA+
12	Grey	mA-

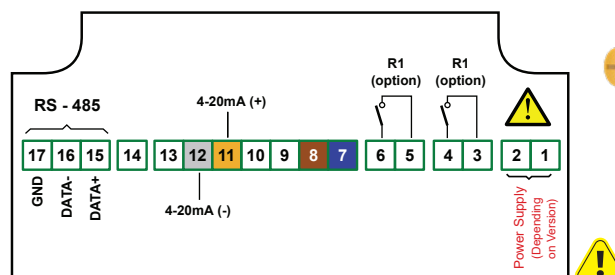



# LevelPro® — TVF Series

## Flow Display | Controller | Batcher

UF 1000   4000   5000 – Pulse Output		
GPM/Pulse = K factor		
TVF Terminal	Pin	Description
8	1	+VDC
10	2	Pulse
7	3	-VDC
Jump 13 & 8		

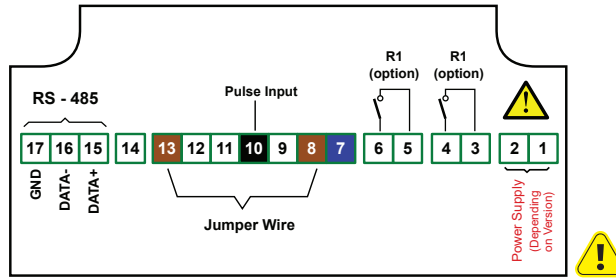

UF 1000   4000   5000 – 4-20mA Output		
TVF Terminal	Pin	Description
8	1	+VDC
11	2	+mA
7	3	-VDC
Jump 12 & 7		

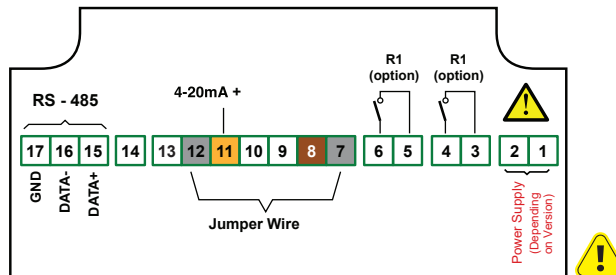

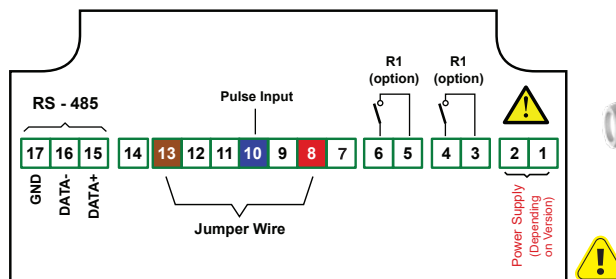

ProPulse (Flying Lead) – Pulse Output		
GPM/Pulse = K factor		
TVF Terminal	Wire Color	Description
7	Shield	-VDC
8	Red	+VDC
10	Blue	Pulse
Jump 13 & 8		

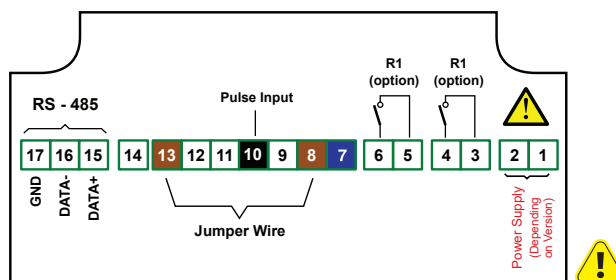

ProPulse®2 – Pulse Output		
TVF Terminal	Wire Color	Description
7	Blue	-VDC
8	Brown	+VDC
10	Black	Pulse
Jump 13 & 8		



### Programming K Factor (For Pulse Input Models)













STEPS	DISPLAY	OPERATION
<b>1 Main Display</b>  ESC MENU  3 SEC		MAIN DISPLAY
<b>2 Relay 1</b>  X 2		RELAY 1 Settings
<b>3 Input</b>  ENTER PAUSE		INPUT Menu
<b>4 K Factor</b>  ENTER PAUSE		Press  or  → Select <b>PULSEL</b> (K Factor)
<b>5 K Factor Value</b>  ENTER PAUSE  2 SEC		Enter <b>K FACTOR</b> Value Press  or  to change digit Press  to advance to next digit Note: Enter the K Factor value according to the Flow Unit. Eg: To display flow in GPM, Enter K Factor corresponding to GPM.
<b>6 Save Value</b>  ENTER PAUSE		Save Selection
<b>7 K Factor</b>  ESC MENU		PULSEL
<b>8 Input</b>  ESC MENU		Input Menu
<b>9 Main Display</b>		Main Display

### Programming 4-20mA Input (For 4-20mA Input Models)

STEPS	DISPLAY	OPERATION
<b>1 Main Display</b>   		<b>MAIN DISPLAY</b>
<b>2 Relay 1</b>   X 2		<b>RELAY 1</b> Settings
<b>3 Flow Menu</b>  		<b>FLOW</b> Menu
<b>4 Input Type</b>   X 6		<b>INPUT TYPE</b> Factory Default: 4-20mA
<b>5 Low Calibration (4mA)</b>  		<b>LOW CALIBRATION</b> Setting Lo CAL = 4mA Value
<b>6 4mA Value</b>   		Enter <b>4mA</b> Value Factory Default: 000.0
<b>7 Save Selection</b>  		Save Selection
<b>8 Low Calibration (4mA)</b>  		Low Calibration Setting
<b>9 High Calibration (20mA)</b>  		<b>HIGH CALIBRATION</b> Setting Hi CAL = 20mA Value











# LevelPro® — TVF Series

## Flow Display | Controller | Batcher

STEPS	DISPLAY	OPERATION
<p>10 <b>20mA Value</b></p> 		<p>Enter <b>20mA</b> Value Factory Default: 100.0</p> <p>Press  or  to change digit Press  to advance to next digit</p>
<p>11 <b>Save Selection</b></p> 		<p>Save Selection</p>
<p>12 <b>High Calibration (20mA)</b></p> 		<p>High Calibration Setting</p>
<p>13 <b>Flow Menu</b></p> 		<p>Flow Menu</p>
<p>14 <b>Main Display</b></p>		<p>Main Display</p>







### Programming Relays

STEPS	DISPLAY	OPERATION
<b>1 Main Display</b>   		<b>MAIN DISPLAY</b>
<b>2 Relay 1</b>  		<b>RELAY 1</b> Settings
<b>3 Source</b>  		<b>SOURCE</b> Menu
<b>4 FLo   bAt   tot</b>  		Press  or  → Select <b>FLo</b> (Flow)
<b>5 Save</b>  		Save Selection
<b>6 Source</b>  		Source
<b>7 Set Point 1</b>  		<b>SET POINT 1</b>
<b>8 Set Point 1 Value</b>   		Enter <b>SET POINT 1</b> Value Press  or  to change digit Press  to advance to next digit
<b>9 Save</b>  		Save Value
<b>10 Set Point 1</b>  		<b>SET POINT 1</b>

STEPS	DISPLAY	OPERATION
<b>11 Set Point 2</b> 		<b>SET POINT 2*</b> * Option available only when the MODE is set to In/Out
<b>12 Set Point 2 Value</b>  2 SEC		Enter <b>SET POINT 2</b> Value Press  or  to change digit Press  to advance to next digit
<b>13 Save</b> 		Save Value
<b>14 Set Point 2</b> 		Set Point 2
<b>15 Hysterisis</b> 		<b>HYSTERISIS</b> Menu
<b>16 Hysterisis Value</b>  2 SEC		Enter <b>HYSTERISIS</b> Value Press  or  to change digit Press  to advance to next digit
<b>17 Save</b> 		Save Value
<b>18 Hysterisis</b> 		Hysterisis Menu
<b>19 Mode</b> 		<b>MODE</b> Menu
<b>20 On   Off   In   Out</b> 		Press  or  → Select <b>On   OFF   In   Out</b>

# LevelPro® — TVF Series

## Flow Display | Controller | Batcher





































STEPS	DISPLAY	OPERATION
<p>21 <b>Save</b> ▶</p> 		Save Selection
<p>22 <b>Mode</b> ▶</p> 		Mode Menu
<p>23 <b>Relay 1</b> ▶</p> 		Relay 1 Menu
<p>24 <b>Main Display</b> ▶</p>		Main Display

### Programming Batching

STEPS	DISPLAY	OPERATION
1 <b>Main Display</b>		<b>MAIN DISPLAY</b>
<b>ESC MENU</b> 3 SEC		
2 <b>Relay 1</b>		<b>RELAY 1</b> Settings
3 <b>Source</b>		<b>SOURCE</b> Menu
4 <b>FLo   bAt   tot</b>		Press  or  → Select <b>bAt</b> (Batch)
5 <b>Save</b>		Save Selection
6 <b>Source</b>		Source Menu
7 <b>Set Point</b>		<b>SET POINT</b>
8 <b>Set Point Value</b>		Enter <b>SET POINT</b> Value Press  or  to change digit Press  to advance to next digit
2 SEC		
9 <b>Save</b>		Save Value
10 <b>Set Point</b>		Set Point
11 <b>Relay 1</b>		Relay 1 Menu
12 <b>Main Display</b>		Main Display
13 <b>Batching Mode</b>		<b>BATCHING MODE</b> 
to start batching		<b>Note:</b> Switching between Flow rate, Totalizer and Batching can be done by pressing $\Sigma$ /RESET button. Kind of displayed value is signalled by " $\Sigma$ " LED. $\Sigma$ LED ON : Totalizer   $\Sigma$ LED OFF: Flow Rate   $\Sigma$ LED Pulsing: Batching































### Programming Output (For 4-20mA Output Models)





















STEPS	DISPLAY	OPERATION
<b>1 Main Display</b>   		<b>MAIN DISPLAY</b>
<b>2 Relay 1</b>   		Relay 1 Settings
<b>3 Output</b>  		<b>OUTPUT</b> Menu
<b>4 Output Mode</b>  		<b>OUTPUT MODE</b>
<b>5 4-20mA</b>  		Press  or  → Select <b>4-20</b>
<b>6 Save</b>  		Save Selection
<b>7 Output Mode</b>  		Select <b>OUTPUT MODE</b>
<b>8 Source</b>  		<b>SOURCE</b> Menu
<b>9 FLo   bAt   tot</b>  		Press  or  → Select <b>FLo</b> (Flow)
<b>10 Save</b>  		Save Selection







# LevelPro® — TVF Series

## Flow Display | Controller | Batcher

STEPS	DISPLAY	OPERATION
<b>11 Source</b> 		Source Menu
<b>12 4mA</b> 		Setting <b>4mA (LOW VALUE)</b>
<b>13 4mA Value</b>  		Enter <b>4mA Value</b> Press  or  to change digit Press  to advance to next digit
<b>14 Save</b> 		Save Value
<b>15 4mA</b> 		4mA (Low Value)
<b>16 20mA</b> 		Setting <b>20mA (HIGH VALUE)</b>
<b>17 20mA Value</b>  		Enter <b>20mA Value</b> Press  or  to change digit Press  to advance to next digit
<b>18 Save</b> 		Save Value
<b>19 20mA</b> 		20mA (High value)
<b>20 Output</b> 		Output Menu
<b>21 Main Display</b>		Main Display

### Resetting Batch

STEPS	DISPLAY	OPERATION
<p>1 <b>Main Display</b></p> 		<b>MAIN DISPLAY</b>
<p>2 <b>Relay 1</b></p> 		Relay 1 Settings
<p>3 <b>Batch Settings</b></p> 		<b>BATCH</b> Menu
<p>4 <b>Batch Resolution</b></p> 		<b>BATCH RESOLUTION</b>
<p>5 <b>Mode Clear</b></p> 		<b>MODE CLEAR</b>
<p>6 <b>off   on</b></p> 		Press  or  → Select <b>on</b>
<p>7 <b>Save</b></p> 		Save Selection
<p>8 <b>Mode Clear</b></p> 		Mode Clear
<p>9 <b>Batch Settings</b></p> 		Batch Menu
<p>10 <b>Main Display</b></p> 		Main Display







STEPS	DISPLAY	OPERATION
<p>11 <b>Batching Mode</b></p> 		<p><b>BATCHING MODE</b></p>  <p><b>Note:</b> Switching between Flow rate, Totalizer and Batching can be done by pressing <math>\Sigma</math>/RESET button. Kind of displayed value is signalled by "<math>\Sigma</math>" LED.</p> <p><math>\Sigma</math> LED ON : Totalizer   <math>\Sigma</math> LED OFF: Flow Rate   <math>\Sigma</math> LED Pulsing: Batching</p>
<p>12 <b>Clear Batch</b></p> 		<p>Clear Batch</p>
<p>13 <b>Main Display</b></p>		<p>Main Display</p>

### Resetting Totalizer

STEPS	DISPLAY	OPERATION
<p>1 <b>Main Display</b></p> 		<p><b>MAIN DISPLAY</b></p>
<p>2 <b>Relay 1</b></p> 		<p>Relay 1 Settings</p>
<p>3 <b>Totalizer Menu</b></p> 		<p><b>TOTALIZER</b> Menu</p>
<p>4 <b>Totalizer Resolution</b></p> 		<p><b>BATCH RESOLUTION</b></p>
<p>5 <b>Mode Clear</b></p> 		<p><b>MODE CLEAR</b></p>
<p>6 <b>OFF   on</b></p> 		<p>Press  or  → Select <b>on</b></p>

# LevelPro® — TVF Series

## Flow Display | Controller | Batcher

STEPS	DISPLAY	OPERATION
<b>7 Save</b> 		Save Selection
<b>8 Mode Clear</b> 		Mode Clear
<b>9 Totalizer Menu</b> 		Totalizer Menu
<b>10 Main Display</b> 		Main Display
<b>11 Totalizer Mode</b> 		<b>TOTALIZER MODE</b>  <p><b>Note:</b> Switching between Flow rate, Totalizer and Batching can be done by pressing <math>\Sigma</math>/RESET button. Kind of displayed value is signalled by "<math>\Sigma</math>" LED.  <math>\Sigma</math> LED ON : Totalizer   <math>\Sigma</math> LED OFF: Flow Rate   <math>\Sigma</math> LED Pulsing: Batching</p>
<b>12 Clear</b> 		Clear Totalizer
<b>13 Main Display</b>		Main Display

### Setting Decimal Point

STEPS	DISPLAY	OPERATION
<b>1 Main Display</b>   		<b>MAIN DISPLAY</b>
<b>2 Relay 1</b>   X 3		Relay 1 Settings
<b>3 Flow Menu</b>  		<b>FLOW</b> Menu *
<b>4 Flow Precision</b>  		<b>FLOW PRECISION</b>
<b>5 Decimal Point</b>  		<b>DECIMAL POINT</b>
		Press  or  to change Decimcal Point
<b>6 Save</b>  		Save Selection
<b>7 Flow Precision</b>  		Flow Precision
<b>8 Flow Menu</b>  		Flow Menu
<b>9 Main Display</b>		Main Display

\* To change decimal points for Batch | Totalizer, select Batch | Totalizer Menu

## Warranty, Returns and Limitations

### Warranty

**Icon Process Controls Ltd** warrants to the original purchaser of its products that such products will be free from defects in material and workmanship under normal use and service in accordance with instructions furnished by **Icon Process Controls Ltd** for a period of one year from the date of sale of such products. **Icon Process Controls Ltd** obligation under this warranty is solely and exclusively limited to the repair or replacement, at Icon Process Controls Ltd option, of the products or components, which **Icon Process Controls Ltd** examination determines to its satisfaction to be defective in material or workmanship within the warranty period. **Icon Process Controls Ltd** must be notified pursuant to the instructions below of any claim under this warranty within thirty (30) days of any claimed lack of conformity of the product. Any product repaired under this warranty will be warranted only for the remainder of the original warranty period. Any product provided as a replacement under this warranty will be warranted for the one year from the date of replacement.

### Returns

Products cannot be returned to **Icon Process Controls Ltd** without prior authorization. To return a product that is thought to be defective, go to [www.iconprocon.com](http://www.iconprocon.com), and submit a customer return (MRA) request form and follow the instructions therein. All warranty and non-warranty product returns to **Icon Process Controls Ltd** must be shipped prepaid and insured. **Icon Process Controls Ltd** will not be responsible for any products lost or damaged in shipment.

### Limitations

This warranty does not apply to products which: 1) are beyond the warranty period or are products for which the original purchaser does not follow the warranty procedures outlined above; 2) have been subjected to electrical, mechanical or chemical damage due to improper, accidental or negligent use; 3) have been modified or altered; 4) anyone other than service personnel authorized by **Icon Process Controls Ltd** have attempted to repair; 5) have been involved in accidents or natural disasters; or 6) are damaged during return shipment to **Icon Process Controls Ltd** reserves the right to unilaterally waive this warranty and dispose of any product returned to **Icon Process Controls Ltd** where: 1) there is evidence of a potentially hazardous material present with the product; or 2) the product has remained unclaimed at **Icon Process Controls Ltd** for more than 30 days after **Icon Process Controls Ltd** has dutifully requested disposition. This warranty contains the sole express warranty made by **Icon Process Controls Ltd** in connection with its products. **ALL IMPLIED WARRANTIES, INCLUDING WITHOUT LIMITATION, THE WARRANTIES OF MERCHANTABILITY AND FITNESS FOR A PARTICULAR PURPOSE, ARE EXPRESSLY DISCLAIMED.** The remedies of repair or replacement as stated above are the exclusive remedies for the breach of this warranty. **IN NO EVENT SHALL Icon Process Controls Ltd BE LIABLE FOR ANY INCIDENTAL OR CONSEQUENTIAL DAMAGES OF ANY KIND INCLUDING PERSONAL OR REAL PROPERTY OR FOR INJURY TO ANY PERSON. THIS WARRANTY CONSTITUTES THE FINAL, COMPLETE AND EXCLUSIVE STATEMENT OF WARRANTY TERMS AND NO PERSON IS AUTHORIZED TO MAKE ANY OTHER WARRANTIES OR REPRESENTATIONS ON BEHALF OF Icon Process Controls Ltd.** This warranty will be interpreted pursuant to the laws of the province of Ontario, Canada.

If any portion of this warranty is held to be invalid or unenforceable for any reason, such finding will not invalidate any other provision of this warranty.

For additional product documentation and technical support visit:

[www.iconprocon.com](http://www.iconprocon.com) | e-mail: [sales@iconprocon.com](mailto:sales@iconprocon.com) or [support@iconprocon.com](mailto:support@iconprocon.com) | Ph: 905.469.9283