

# 1575e QUICK-START GUIDE – COOLING TOWER, SECONDARY CONDUCTIVITY TRANSMITTER

**1** ATTACH THE FOUR MOUNTING FEET TO THE BACK OF THE CONTROLLER ENCLOSURE

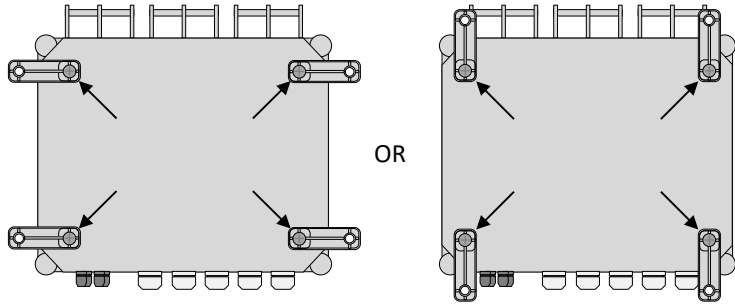

**2** FASTEN THE CONTROLLER TO A FLAT, NON-VIBRATING SURFACE. AVOID METAL SURFACES THAT EXPERIENCE LARGE TEMPERATURE SWINGS.

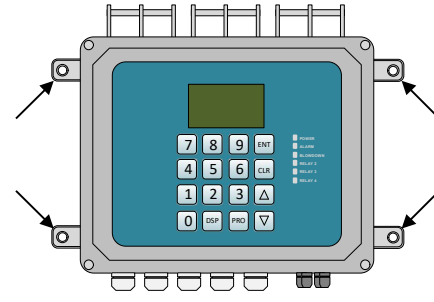

**3** INSTALL BLOWDOWN VALVE, PLUMBING ASSEMBLIES, SENSORS, TRANSMITTER, WATER METERS AND PUMPS, AS APPLICABLE.

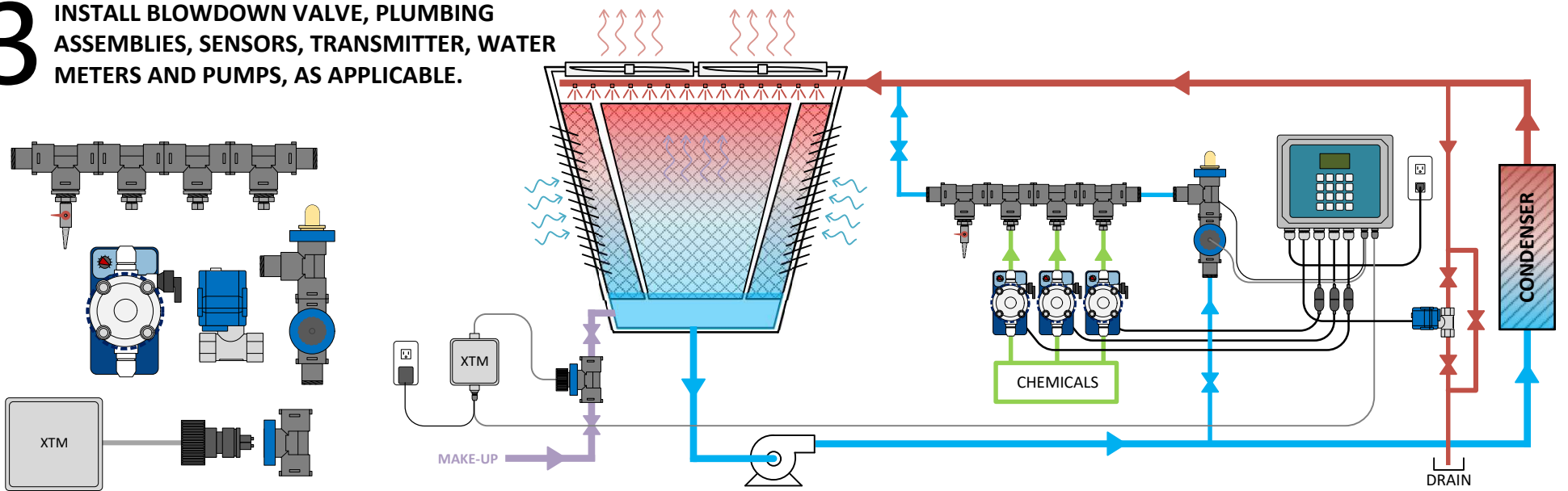

**4** WIRE THE BLOWDOWN VALVE, CONDUCTIVITY SENSOR, WATER METERS AND 4-20mA IN/OUT, IF APPLICABLE.

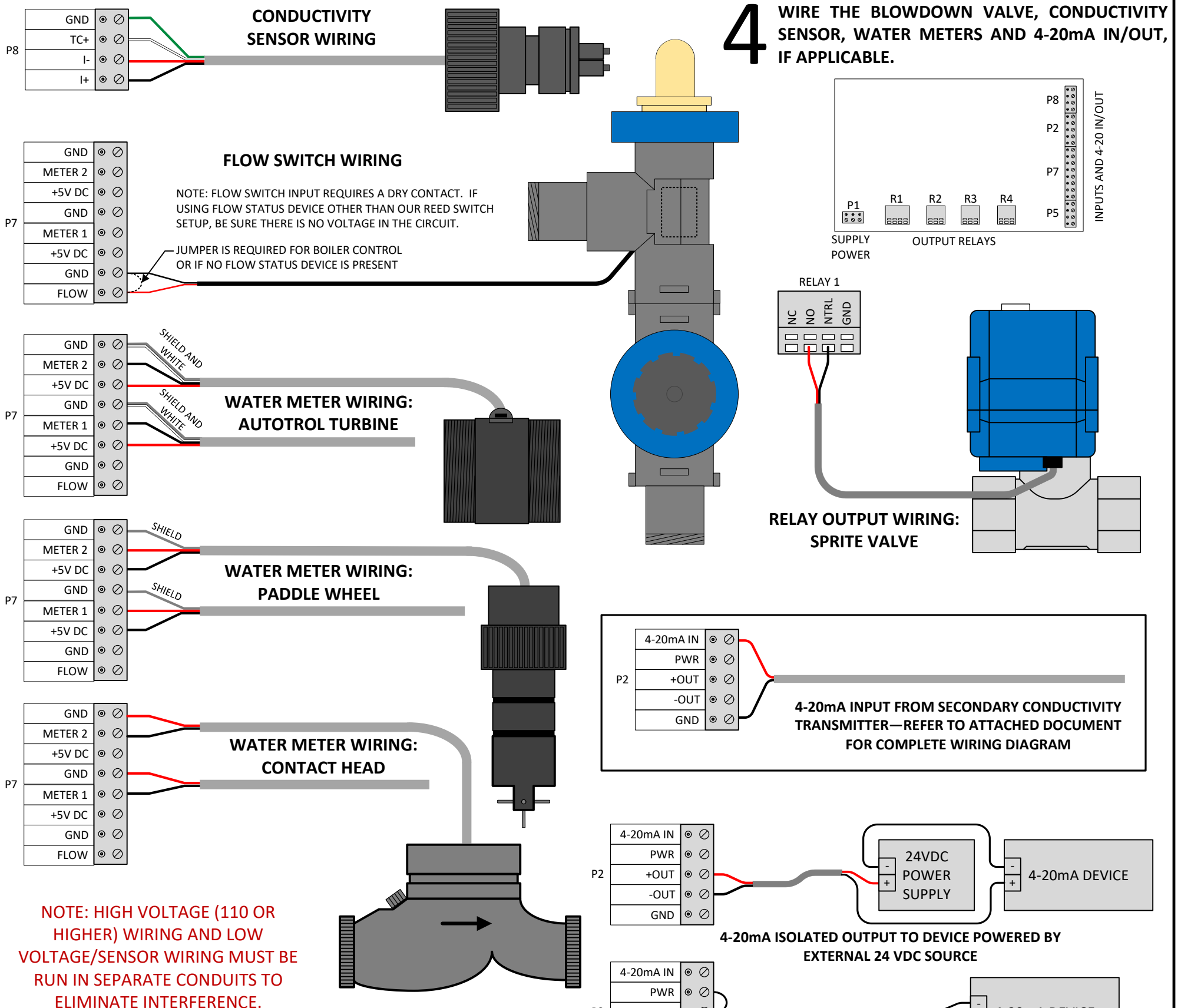

**5** ENSURE WIRING CONNECTIONS ARE CORRECT BEFORE CONTINUING TO PAGE 2.

# 1575e QUICK-START GUIDE – COOLING TOWER, SECONDARY CONDUCTIVITY TRANSMITTER

## 5 APPLY POWER TO THE CONTROLLER

**NOTE: ONLY PLUG INTO PROPERLY GROUNDED OUTLET—DO NOT MODIFY THE PLUG IN ANY WAY.**

**NOTE: IF WIRING DIRECTLY TO CONTROLLER P1 TERMINALS, BE SURE SOURCE IS PROPERLY GROUNDED.**

## 6 CONTROLLER INTERFACE

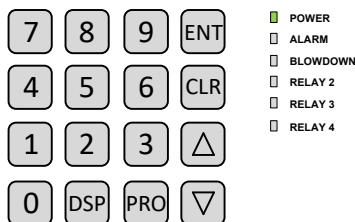

The controller is set up at the factory to accommodate the secondary Conductivity input. When the controller is first powered up, you should see this screen. Press any key to access the Process screen.

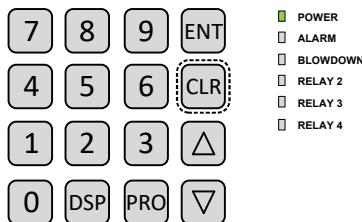
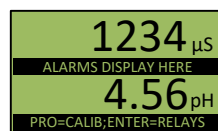

This is the Process screen. It displays the current conductivity, relay status and any active alarms. The LED's also show relay status and if any alarms are active. Press "CLR" to access the Main Menu.

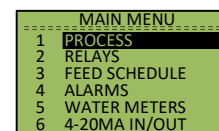

This is the Main Menu. Menu items are accessed by either pressing the associated number keys or using up/down arrows to highlight the desired item and pressing "ENT" to select. Selecting #1 (PROCESS) returns you to the Process screen, shown to the left. Other menu items will be referred to in the following steps.

Note: There are two additional menu items that show up if the down arrow is pressed past #6. (#7-SYSTEM SETUP and #8-CLOCK).

## 7 CHECK DATE/TIME

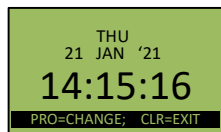

Press the "PRO" key to change the date/time.

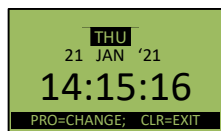

Use the up/down arrows to change day of week and month. Use number keys for date, year and time. Press the "ENT" key to move to the next field.

Note: The "ENT" key must be pressed for all fields for any changes to be saved.

The controller date/time are set at the factory as part of pre-ship testing. The time is set to Central Standard Time (CST) and may require adjustment for your time zone.

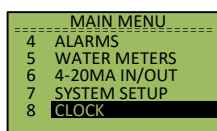

From the Main Menu, press the "8" key or highlight #8 and press "ENT" to access the Clock screen.

## 8 TEST RELAY OUTPUTS

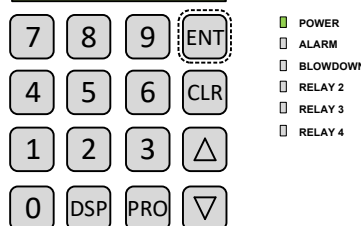
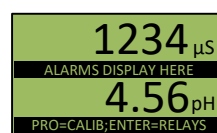

From the Process screen, press "ENT" to access the Relay Override screen.

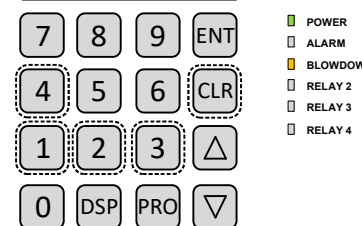
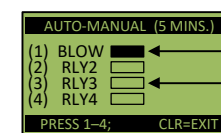

This is the Manual Override screen. Press keys 1-4 to activate/de-activate the associated relays. Verify valve and/or pump operation. The override will automatically release after 5 minutes. Press "CLR" to return to the Process Screen.

## 9 SENSOR CALIBRATION

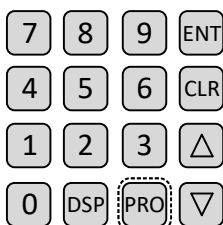
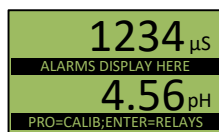

While on the Process screen, press "PRO" to access the Calibration choice screen. Select either "CONDUCTIVITY" or "SECONDARY INPUT" (Ph).

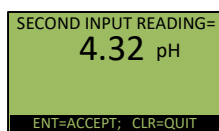
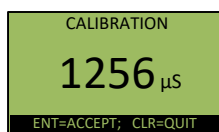

These are the Calibration screens. Enter the value from your hand-held tester here.



Refer to pages 25-27 in the 1575e manual for more information.

## 10 CONFIGURE WATER METERS

IF NO WATER METERS ARE USED, SKIP TO STEP 11

You will need to correctly configure the water meter inputs to ensure accurate flow totals.

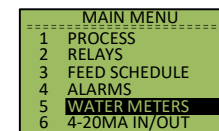

From the Main Menu, press the "5" key or highlight #5 and press "ENT" to access the Meter Configuration screen.



Refer to page 48 in the 1575e manual for more information.

## 11 CONFIGURE RELAYS

You will need to configure the blowdown relay and chemical relays.

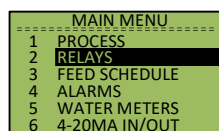

On the main menu, press the "2" key or highlight #2 and press "ENT" to access the relay configuration screen.



Refer to page 30 in the 1575e manual for more information.

Note: The Blowdown relay is configured at the factory for "Cycles of Concentration" control method. You'll need to input a cycles setpoint and minimum based on specific site conditions.

Refer to page 34 in the 1575e manual for more information.

## 12 SET UP FEED PUMP SCHEDULES

If any relays (2, 3 or 4) have been configured as "FEED SCHEDULE" you will need to set up one or more schedules to control them.

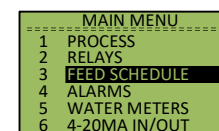

On the main menu, press the "3" key or highlight #3 and press "ENT" to access the Feed Schedule setup screens.



Refer to page 45 in the 1575e manual for more information.

Thank you for your purchase of this Lakewood Instruments controller. We would like to know what features **YOU** would like to see in our next new product.

Please let us know!



<https://survey.zohopublic.com/zs/dZBUTn>

# 1575e SECONDARY CONDUCTIVITY TRANSMITTER WIRING

