

# 600 & 6000 Series

## HYDRAULIC METERING PUMPS

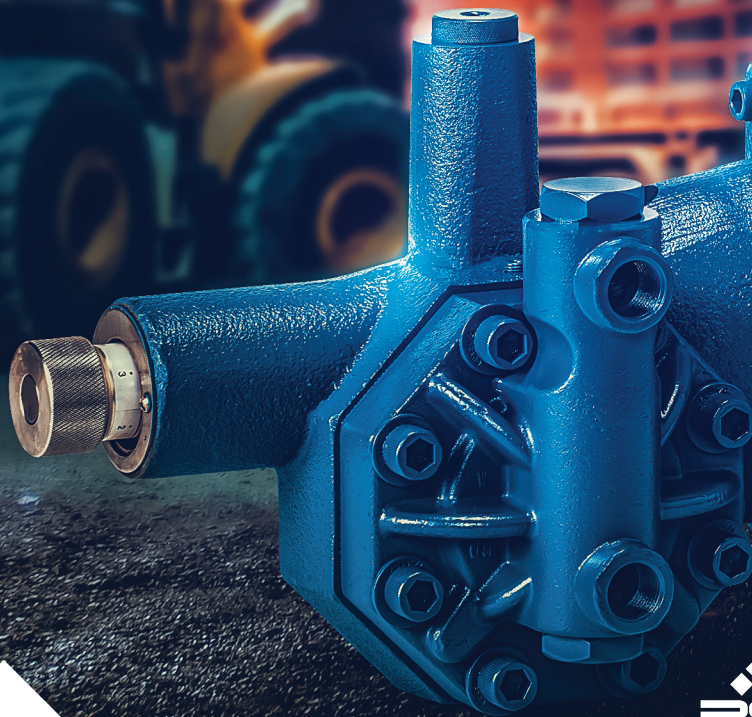

Where Innovation Flows

**Neptune**



Neptune 600 and 6000 Series Hydraulic Metering Pumps are designed for high-pressure, high-volume applications and are available in both simplex or duplex models. The 600 and 6000 Series pumps have an adjustable pump capacity through the use of a micrometer dial that can be varied while pump is running or stopped. These pumps also utilize a hydraulically-balanced PTFE diaphragm that eliminates stress.

Variable Oil By-Pass™ Stroke Adjustment provides better valve performance when compared to variable linkage designs. This increase in performance is the result of valve checks that provide extra time to seat even in viscous liquids since they are idle during the by-pass portion of the suction and discharge strokes.

### FEATURES AND BENEFITS

- EZE-CLEAN™ valves are removable without disturbing piping
- Power train operates submerged in oil for extended service
- Standard motor of 1/2HP to 3HP
- Max capacity up to 641 gph (2,426 L/h)
- Max pressure up to 4,000 psi (275.8 bar)
- Material of Construction: 316SS, C-20, PVDF, PVC

### OPTIONS

- Capacity control options include electric stroke length adjustment, variable speed drives and double-diaphragm leak detection

# 600 and 6000 Series Hydraulic Metering SELECTION CHART

MODEL	PISTON DIAMETER INCHES (MM)	STROKES PER MINUTE 60 HZ (50 HZ)	MATERIALS OF CONSTRUCTION	MAX CAPACITY 60 HZ (50 HZ)		MAX PRESSURE												SHIPPING WEIGHT LB. (KG)
						1/2 HP		3/4 HP		1 HP		1-1/2 HP		2 HP		3 HP		
				GPH	L/H	PSI	BAR	PSI	BAR	PSI	BAR	PSI	BAR	PSI	BAR	PSI	BAR	
6100-N3**	3/4 (19.1)	58 (48)	316SS	7 (5.8)	26.5 (22.1)	1,200	84	2,000	137.9	2,500	172.4	3,500	241.3	4,000	275.8	N/A	N/A	90 (41)
6150-N3**		117 (97)	316SS	14.7 (12.3)	56 (46.7)	1,000	70	1,500	103.3	2,000	137.9	3,000	206.8	3,500	241.3	N/A	N/A	90 (41)
6250-N3	1 (25.4)	117 (97)	316SS	28 (23.3)	106 (88.3)	500	34.5	800	55.2	1,000	69	1,500	103.3	2,000	137.9	N/A	N/A	90 (41)
635-N3	2 (50.8)	117 (97)	316SS	130 (108.3)	492 (410)	N/A	N/A	225	15.5	275	19	425	29.3	600	41.4	N/A	N/A	160 (76)
635-N4			C-20			N/A	N/A	225	15.5	275	19	425	29.3	600	41.4	N/A	N/A	160 (76)
635-N5	2 (50.8)	117 (97)	PVC*	130 (108.3)	492 (410)	N/A	N/A	150	10.3	N/A	N/A	N/A	N/A	N/A	N/A	N/A	N/A	205 (93)
635-N8			PVDF			N/A	N/A	150	10.3	N/A	N/A	N/A	N/A	N/A	N/A	N/A	N/A	N/A
637-N3	2 (50.8)	144 (120)	316SS	160 (133.3)	605 (504.1)	N/A	N/A	225	15.5	275	19	425	29.3	600	41.4	N/A	N/A	190 (86)
637-N4†			C-20			N/A	N/A	225	15.5	275	19	425	29.3	600	41.4	N/A	N/A	190 (86)
637-N5	2 (50.8)	144 (120)	PVC*	160 (133.3)	605 (504.1)	N/A	N/A	150	10.3	N/A	N/A	N/A	N/A	N/A	N/A	N/A	N/A	205 (93)
637-N8†			PVDF			N/A	N/A	150	10.3	N/A	N/A	N/A	N/A	N/A	N/A	N/A	N/A	N/A
647-N3	2-1/2 (63.5)	144 (120)	316SS	240 (200)	908 (756.7)	N/A	N/A	N/A	N/A	N/A	N/A	N/A	N/A	200	13.8	N/A	N/A	220 (100)
647-N4†			C-20			N/A	N/A	N/A	N/A	N/A	N/A	N/A	N/A	N/A	N/A	200	13.8	N/A
647-N5	2-1/2 (63.5)	144 (120)	PVC*	240 (200)	908 (756.7)	N/A	N/A	N/A	N/A	N/A	N/A	N/A	N/A	150	13.8	N/A	N/A	205 (93)
647-N8†			PVDF			N/A	N/A	N/A	N/A	N/A	N/A	N/A	N/A	N/A	150	13.8	N/A	N/A
<b>HIGH CAPACITY MODELS</b>																		
657-N3	3 (76.2)	144 (120)	316SS	377 (313)	1427 (1184)	N/A	N/A	N/A	N/A	N/A	N/A	N/A	N/A	150	10.3	225	15.5	270 (122)
657-N4†			PVDF			N/A	N/A	N/A	N/A	N/A	N/A	N/A	N/A	N/A	N/A	150	10.3	225
657-N5	3 (76.2)	144 (120)	PVC*	377 (313)	1427 (1184)	N/A	N/A	N/A	N/A	N/A	N/A	N/A	N/A	150	10.3	150	10.3	270 (122)
657-N8†			PVDF			N/A	N/A	N/A	N/A	N/A	N/A	N/A	N/A	N/A	150	10.3	150	10.3
658-N3	3 (76.2)	176 (146)	316SS	463 (384)	1753 (1455)	N/A	N/A	N/A	N/A	N/A	N/A	N/A	N/A	120	8.3	190	13.1	270 (122)
658-N4†			PVDF			N/A	N/A	N/A	N/A	N/A	N/A	N/A	N/A	N/A	120	8.3	190	13.1
658-N5	3 (76.2)	176 (146)	PVC*	463 (384)	1753 (1455)	N/A	N/A	N/A	N/A	N/A	N/A	N/A	N/A	120	8.3	150	10.3	270 (122)
658-N8†			PVDF			N/A	N/A	N/A	N/A	N/A	N/A	N/A	N/A	N/A	120	8.3	150	10.3
667-N3	3-1/2 (88.9)	144 (120)	316SS	534 (443)	2021 (1678)	N/A	N/A	N/A	N/A	N/A	N/A	N/A	N/A	110	7.6	170	11.7	270 (122)
667-N4†			PVDF			N/A	N/A	N/A	N/A	N/A	N/A	N/A	N/A	N/A	110	7.6	170	11.7
667-N5	3-1/2 (88.9)	144 (120)	PVC*	534 (443)	2021 (1678)	N/A	N/A	N/A	N/A	N/A	N/A	N/A	N/A	110	7.6	150	10.3	270 (122)
667-N8†			PVDF			N/A	N/A	N/A	N/A	N/A	N/A	N/A	N/A	N/A	110	7.6	150	10.3
668-N3	3-1/2 (88.9)	176 (146)	316SS	641 (532)	2426 (2014)	N/A	N/A	N/A	N/A	N/A	N/A	N/A	N/A	90	6.2	140	9.7	270 (122)
668-N4†			PVDF			N/A	N/A	N/A	N/A	N/A	N/A	N/A	N/A	N/A	90	6.2	140	9.7
668-N5	3-1/2 (88.9)	176 (146)	PVC*	641 (532)	2426 (2014)	N/A	N/A	N/A	N/A	N/A	N/A	N/A	N/A	90	6.2	140	9.7	270 (122)
668-N8			PVDF			N/A	N/A	N/A	N/A	N/A	N/A	N/A	N/A	N/A	90	6.2	140	9.7

\*PVC head pumps are satisfactory for temperatures to 125°F (52°C).

†ECCN 2B350, Export License may be required.

\*\*3-phase motor required with motors up to 1 hp.

## NOTES

1. **CAPACITY:** Capacity figures are based on water using 1,725 rpm motor. Capacity will decrease by approximately 1.5% for each 100 psi (6.9 bar) increase in pressure.
2. **ACCURACY:** Accuracy is  $\pm 1\%$  of full scale over the range of 10% to 100% of capacity.
3. **TEMPERATURE/VISCOSITY:** Contact factory for temperatures over 200°F (93°C) or viscosity greater than 1,000 cP.

## MATERIALS OF CONSTRUCTION

MATERIAL CODE	PUMP HEAD	CHECK VALVE BODY	CHECK VALVE BALL	VALVE O-RINGS†	DIAPHRAGM
N3	316SS	316SS	316SS	FKM	PTFE
N4	C-20	C-20	C-20††	FKM	PTFE
N5	PVC*	PVC*	Ceramic**	FKM	PTFE
N8	PVDF	PVDF	Ceramic**	FKM	PTFE

\*PVC head pumps satisfactory for temperatures to 125°F (52°C).

\*\*Special materials available for services not compatible with ceramic.

†Valve O-ring for high capacity models is PTFE.

††Valve Checks for high capacity model is C-276.



Model 6100-N3

## MOTOR SELECTION CHART

ENCLOSURE	PHASE	AC VOLTAGE	1/2 HP	3/4 HP	1 HP	1-1/2 HP	2 HP	3 HP
TEFC	1	115/230	100740	100747	100753	N/A	N/A	N/A
TEFC	3	230/460	100742	100749	100755	100761	100767	132022
EXP	1	115/230	100744	100751	100757	N/A	N/A	N/A
EXP	3	230/460	100745	100752	100758	100764	100770	N/A
CPSD	1	115/230	100741	100748	100754	N/A	N/A	N/A
CPSD	3	230/460	100746	100750	100756	100762	100768	N/A

To select correct motor from the chart on the left, determine the following:

- Horsepower requirement from chart above
- Power supply voltage and phase
- Enclosure requirement (options available in all 600 series pump sizes)
- Include the different types of enclosures

Neptune offers Totally Enclosed Fan Cooled (TEFC), Explosion Proof (EXP), and Chemical Plant Severe Duty (CPSD) enclosures.

Model 647-N8

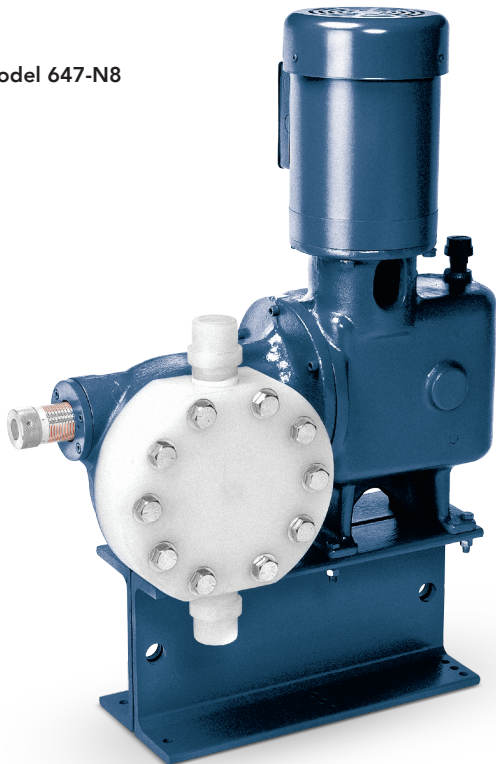

Model 668-N3



## DIMENSIONS

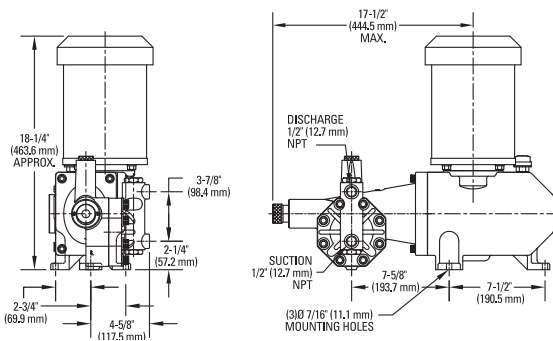

Models 6100/6150/6250 (316SS Heads)

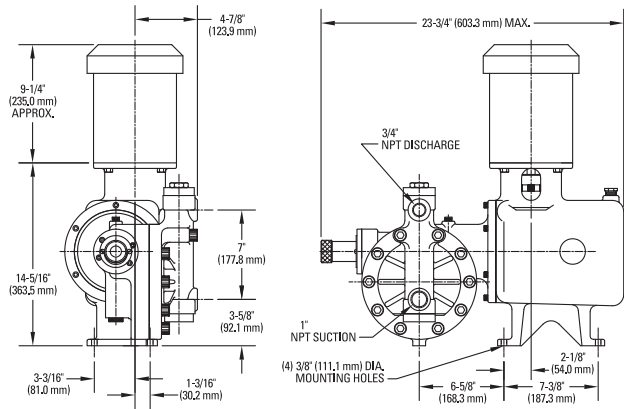

Models 635/637 (316SS & C-20 Heads)

## ORDERING INFORMATION

When ordering, the following information is required:

1. Description of liquid to be pumped, which includes:
  - Chemical name
  - Concentration
  - Viscosity
  - pH and temperature of solution
2. Maximum, normal and minimum pump capacity
3. Discharge pressure
4. Suction conditions
5. Motor characteristics

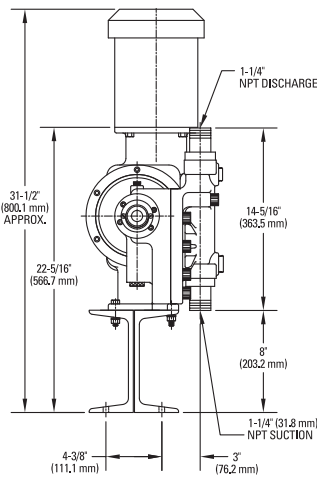

Model 647  
(316SS & C-20 Heads)

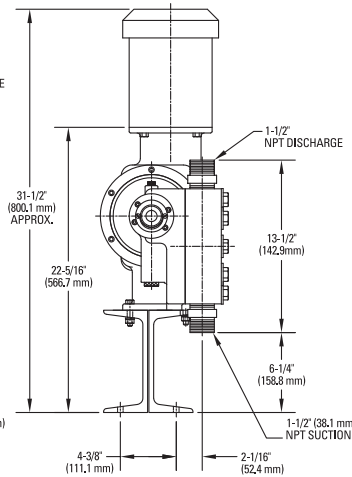

Models 635/637/647  
(PVC & PVDF Heads)

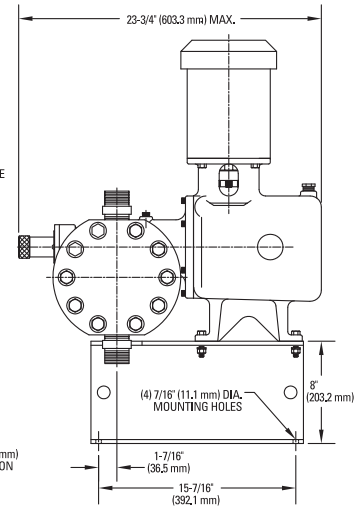

Models 635/637 (PVC & PVDF)  
Models 647 (All Materials)

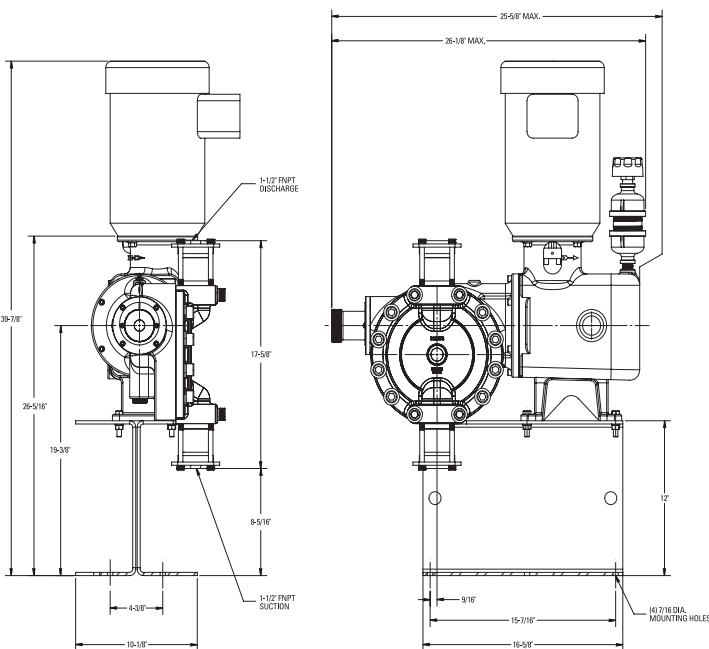

Models 657/658/667/668 (316SS & C-20 HEADS)

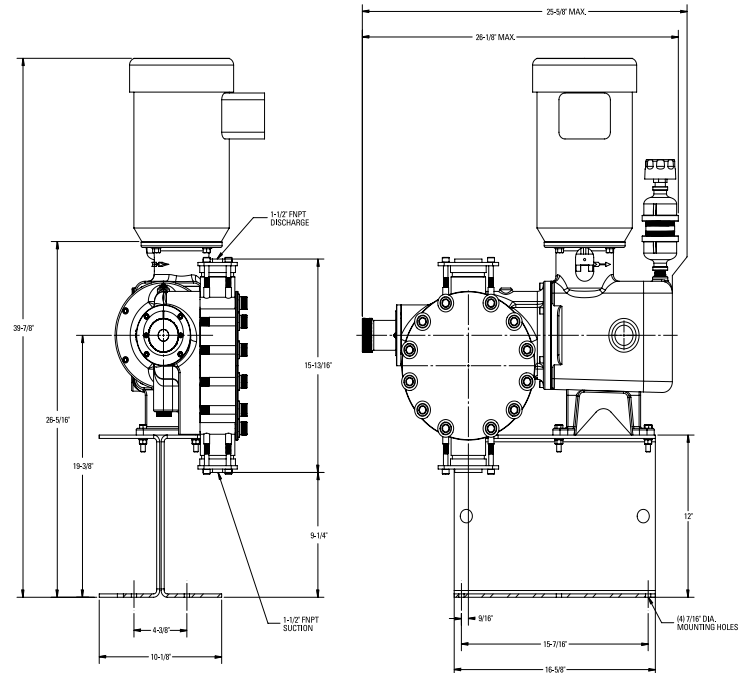

Models 657/658/667/668 (PVC & PVDF HEADS)

# Additional Solutions by Neptune

## DOUBLE-DIAPHRAGM LEAK DETECTION

Neptune offers a double diaphragm leak detection option for applications where contamination of the process fluid by the pump hydraulic fluid cannot be tolerated or where diaphragm failure must be sensed immediately.

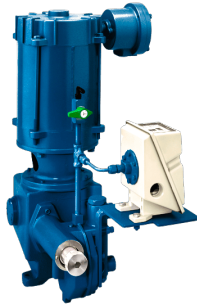

The double diaphragm option "DD" is available on 600 Series Neptune hydraulic metering pumps with Metal Liquid Head (316SS & C-20 Heads).

## ADVANCED STROKE CONTROLLER

The flow rate of any Neptune hydraulic metering pump can be controlled automatically by a process instrument, or manually from a remote location, using the Advanced Stroke Controller to adjust stroke length. The Neptune Advanced Stroke Controller is a one-piece, self-contained Electric Positioner mounted on the pump.

- 60/50 Hz, 110/240 VAC
- Unit follows 4-20mA signal (Travel adjustable)
- Type 4, IP67 Rating Enclosure
- Four buttons LCD User Interface
- Certified Explosion proof to CEC



- Direct (forward) or indirect (reverse) response to changing signal
- Manual override in event of instrument signal or power loss

## CHEMICAL FEED SYSTEMS

For a more complete wastewater application solution, Neptune offers packaged chemical feed systems.



## POLYMER BLEND & FEEDS

Polymaster™ dilutes, mixes and thoroughly activates emulsion, dispersion and solution polymers including new high molecularweight products. Our specifications are designed to meet your needs.



## PORTABLE MIXERS

Neptune offers mixers for use with tanks, drums, pails and totes. Direct-drive and gear-drive models from 1/20 HP through 5 HP.



## BACK PRESSURE & PRESSURE RELIEF VALVES

For optimal performance and to protect your equipment, Neptune offers back pressure and pressure relief valves.

- Available in PVC, 316SS, PVDF, and C-20 materials
- Standard sizes include 1/2" through 1-1/2" options



## HIGH-PRESSURE INJECTION QUILLS

Used to inject chemicals pumped into turbulent-flow zone of high-pressure water or steam lines.



- Available in PVC, PVDF, 316SS and C-20 materials
- Special lengths are available up to 24" for CPVC and PVDF; up to 36" for 316SS and C-20

## SAMPLE COOLERS

Cool hot water or steam samples for easy handling and effective sample collection. Suitable for use on hot water, saturated steam or super-heated steam services.

- Available in 316SS and Inconel materials



For more information on these additional solutions, visit us at [psgdoover.com/neptune](http://psgdoover.com/neptune).



PSG  
22069 Van Buren Street  
Grand Terrace  
CA, 92313-5651  
USA  
P: +1 (909) 422-1700  
F: +1 (909) 783-3440  
[psgdover.com/neptune](http://psgdover.com/neptune)



Where Innovation Flows

NPT-10011-C-03

Copyright 2024 PSG®, a Dover company

Authorized PSG® Partner: