



INSTALLATION OPERATION & MAINTENANCE



NEPTUNE SERIES 500/5000 PUMPS

Model 500/5000

500-A, 500-D, 500-E,
500-S and 500-VS



NEP-ZL105638

PSG
22069 Van Buren Street
Grand Terrace, CA 92313 USA
P: +1 (215) 699-8700 F: +1 (215) 699-0370
neptune1.com

Copyright 2018 PSG[®], a Dover Company

NEP-ZL105638
03.2018_REV 7



psgdover.com

WARNING

LOCKOUTS ARE REQUIRED BEFORE
SERVICING THIS EQUIPMENT.

SAFETY INSTRUCTIONS:

Shut off/Lockout pump Power before Servicing.

Be certain pump isolation valves are
Closed and chemical is shut off.

Bleed pressure before servicing.

In case of emergency, shut pump down completely
by disconnecting motor power supply.

To prevent unexpected start-up, disconnect motor
from power supply when power outage happens.

WARNING

Please read thoroughly before installation, operation or maintenance of any Neptune pump

EQUIPMENT MISUSE HAZARD

Equipment misuse can cause the equipment to rupture, malfunction and result in serious injury.

- This equipment is for professional use only.
- Read all instruction manuals, tags, and labels before operating the equipment.
- Use the equipment only for its intended use.
- Do not alter or modify this equipment.
- Be certain all operators of this equipment have been trained for safe working practices, understand its limitations, and wear safety goggles and or equipment when required.
- Do not exceed the maximum working pressure of the system as mentioned on the pump tag.
- Do not use the pump head or the suction or discharge piping to pull the equipment.
- Do not move the pressurized pump.
- Use fluids or cleaning agents for cleaning that are compatible with the pump parts. Read the fluid and cleaning agent manufactures warnings and refer to the material compatibility chart.
- Comply with all applicable local, state, and national safety regulations.
- Do not allow pump to run dry.

PRESSURIZED EQUIPMENT HAZARD

Spray from leaks or ruptured components can splash fluid in the eyes or on the skin and cause serious injury.

- Shut off the pump and depressurize before performing any maintenance.
- Do not tamper with or perform unspecified alteration of this device.
- Operate only at rated pressure. Excessive pressure during normal operation can cause leakage and rupture to the pump head joint and/or pipes. Rated pressure can be found on pump name tag.
- Use only pipe, hose, and hose fittings rated for maximum rated pressure of the pump or the pressure at which the pressure relief valve is set at.
- Always wear protective clothing, face shield, safety glasses and gloves when working on or near your metering pump.
- Additional precautions should be taken depending on the solution being pumped. Refer to SDS precautions from your solution supplier.
- Do not stop or deflect fluid leaks with your hand, body, glove, or rag.
- Tighten all fluid connections before operating the equipment.
- Replace worn, damaged, or loose parts immediately.
- Before performing any maintenance requiring pump head and or valve (wetted parts) disassembly, be sure to relieve pressure from the piping system and where hazardous process chemicals are present.
- Make the pump safe to handle for the personnel and the environment by cleaning and chemically neutralizing the pump as appropriate.
- Wear protective clothing and use proper tools as appropriate to avoid any injury.
- If the diaphragm has failed, the process chemical may have contaminated the pump hydraulic oil. Handle with appropriate care. Clean the pump and replace the oil as necessary. Discard the contaminated oil as per the local code.
- If the diaphragm fails in a double diaphragm pump, pressurized process chemical can be present in the Neptune leak detection vacuum system. Take proper care to clean and handle them.

FIRE AND EXPLOSION HAZARD

Improper grounding, poor air ventilation, open flames, or sparks can cause a hazardous condition and result in fire or explosion and serious injury.

- Ground the equipment. See motor installation instruction for grounding procedure.
- Do not pump non recommended flammable or explosive fluids.
- Static electricity may be generated by fluid moving through pipes and hoses. A static spark could be produced by high fluid flow rate. Earthing of the pump is a must.
- Provide fresh air ventilation to avoid the possible buildup of flammable fumes from the process chemicals.
- Keep the pump area free of debris, including cleaning agent, rags, and any flammable material.
- Follow the cleaning agent and other cleaning recommendations as mentioned in the operation and instruction manuals.
- Use cleaning agent with the highest possible flash point to clean the pump parts if needed.
- If there is any static sparking while using the equipment, stop operation at once. Identify and correct the problem before starting up the pump.

TOXIC FLUID HAZARD

Hazardous fluids or toxic fumes can cause serious injury or death if splashed in eyes or on the skin, swallowed, or inhaled.

- Know the specific hazards of the fluid you are using. Read the fluid manufactures warnings.
- Consider chemical compatibility when selecting pump material. Reference Neptune chemical resistance guide in: <https://www.psgdover.com/neptune/download-library/guides> or contact Neptune Sales for recommendation.
- Store hazardous fluid in an approved container. Dispose of hazardous fluid according to all local, state and national guidelines.
- Wear the appropriate protective clothing, gloves, eyewear and respirator.
- Pipe and dispose of the exhaust air safely. If the diaphragm fails, the fluid may be exhausted along with the air in mechanical diaphragm pump. Also, oil vapor may breathe out of the air breather installed on the gear box.

SOUND HAZARD

The sound pressure level of the pump may exceed 80dBA in some of the pumps.

- Observe all safety precautions when operating the pump within close proximity for extended periods by wearing hearing protectors.
- Extended exposure to elevated sound levels will result in permanent loss of hearing acuteness, tinnitus, tiredness, stress, and other effects such as loss of balance and awareness.

MECHANICAL HAZARD

The pump may shake or vibrate during operation.

TABLE OF CONTENTS

SECTION	PARAGRAPH		PAGE
I	—	GENERAL DESCRIPTION	1
		LIMITED WARRANTY	2
		PARTS ORDERING INSTRUCTIONS	3
II	—	INSTALLATION INSTRUCTIONS	4
	1.0	GENERAL	4
	2.0	SUCTION PIPING	5
	3.0	DISCHARGE PIPING	6
	4.0	ADJUSTMENT OF INTERNAL RELIEF VALVE	6
	5.0	INSTALLATION OUTDOORS	8
	6.0	START-UP, FLOODED SUCTION	8
	7.0	START-UP, SUCTION LIFT	9
	8.0	START-UP, AFTER SUCTION HAS RUN DRY	9
III	—	NORMAL MAINTENANCE AND DISASSEMBLY INSTRUCTIONS	10
	9.0	MAINTENANCE	10
	10.0	REMOVAL OF VALVE CARTRIDGES	11
	11.0	CLEANING OF VALVE CARTRIDGES	11
	12.0	REPLACING OF VALVE CARTRIDGES	11
	13.0	PROCEDURE FOR REPLACING CONTROL ROD AND SEALING PLATE “O” RINGS	12
	14.0	REMOVAL OF PUMP HEAD AND REPLACEMENT OF DIAPHRAGM	13
	15.0	REMOVAL OF STANDARD MOTOR	14
IV	16.0	MOTOR OPERATING CONDITIONS	15
V	—	TROUBLESHOOTING CHART	16
VI	—	INSTRUCTIONS FOR PUMPS WITH ELECTRIC STROKE CONTROL	18
VII	18.0	PARTS LIST	19
VIII	—	DRAWINGS	22
APPENDIX	—	ADDITIONAL INSTRUCTIONS FOR VARIOUS MODEL OPTIONS	
		SERIES 500-E-AR “dia-PUMP”	25
		SERIES 500-E “dia-PUMP”	26
		SERIES 500-A “dia-PUMP”	22
		SERIES 500-VS “dia-PUMP”	29
		SERIES 5000 “dia-PUMP”	30
		DOUBLE DIAPHRAGM OPTION	32

SECTION I GENERAL DESCRIPTION

The Neptune Series 500 “dia-PUMP” is a reliable metering pump of the high-pressure diaphragm type. Under constant conditions of temperature, pressure, and capacity adjustment settings, a +/-1% metered discharge volume is maintained.

A plunger reciprocating at a fixed stroke displaces hydraulic fluid, which actuates a flexible, chemically inert, Teflon® diaphragm to create pumping action. The capacity of the pump is regulated by controlling the volume of hydraulic fluid, which bypasses the diaphragm cavity.

Capacity adjustment can be made manually or automatically by instrument signal.

Metering accuracy is maintained by a control rod, which allows hydraulic fluid replacement and air venting automatically with each stroke, while also taking into account temperature changes of the hydraulic fluid. Metering accuracy is also insured by the use of double ball check valves on the suction and discharge of the pump.

PLEASE READ THE INSTRUCTION MANUAL COMPLETELY BEFORE INSTALLING THE PUMP.



SERIES 500 “dia” PUMP
WITH INTEGRAL TEFC MOTOR



SERIES 500-A “dia” PUMP
WITH INTEGRAL TEFC MOTOR



SERIES 500-E “dia” PUMP
WITH INTEGRAL TEFC MOTOR

The text and illustrations in the main body of this manual are based upon the Series 500 pump, shown at left above. The Series 500-A and 500-E pumps are very similar to the Series 500 pump. The liquid ends are interchangeable.

Please refer to Appendix for all Models other than 500-S or 500-D.

Models 500-A, 500-E, 500-E-AR, 500-VS, 5003, 5005 and the Double Diaphragm Option are described in the Appendix.

**SECTION I
NEPTUNE CHEMICAL PUMP COMPANY
LIMITED WARRANTY**

All Neptune Pumps are tested at the factory prior to shipment. Each part used in their construction has been carefully checked for workmanship.

If the pump is installed properly, Neptune Chemical Pump Company warrants to the purchaser of this product for a period of three years from the date of shipment, this product shall be free of defects in material and/or workmanship, as follows:

1. Neptune Chemical Pump Company will replace, at no charge, any part that fails due to a defect in material and/or workmanship during the warranty period, FOB our factory, North Wales, Pennsylvania. To obtain warranty service, you must forward the defective parts to the factory for examination, freight pre-paid.¹
2. This warranty period does not cover any product or product part which has been subject to accident, misuse, abuse or negligence. Neptune Chemical Pump Company shall only be liable for this warranty if the product is used in the manner intended by the manufacturer as specified in the written instructions furnished with this product.

Any express warranty not provided in this warranty document, and any remedy for breach of contract that, but for this provision, might arise by implication or operation of law, is hereby excluded, and disclaimed. Under no circumstances shall Neptune Chemical Pump Company be liable to purchaser or any other person for any charge for labor, repairs, or parts, performed or furnished by others, nor for any incidental consequential damages, whether arising out of breach of warranty, express or implied, a breach of contract or otherwise. Except to the extent prohibited by applicable law, any implied warranty of merchantability and fitness for a particular purpose are expressly limited in duration to the duration of this limited warranty.

Some states do not allow the exclusion or limitation of incidental or consequential damages or allow limitations on how long any implied warranty lasts, so the above limitations may not apply to you. This warranty gives you specific legal rights, and you may have other rights, which may vary from state to state.

IMPORTANT

SHOULD IT BE NECESSARY TO SEND THE PUMP TO THE FACTORY FOR REPAIR OR MAINTENANCE REBUILDING; DRAIN ALL OIL AND CHEMICAL FROM THE PUMP BEFORE SHIPPING. FAILURE TO DO SO CAN CAUSE EXTENSIVE DAMAGE TO THE MOTOR.

¹SEE IMPORTANT NOTICE -RETURN GOODS AUTHORIZATION

**IMPORTANT NOTICE
RETURN GOODS AUTHORIZATION**

- (1) All equipment returned to Neptune Chemical Pump Company; Inc. requires proper Returned Goods Authorization Number (RGA) and tags.
- (2) All equipment returned to the factory for repair or service must first be thoroughly flushed and have all chemical contact areas neutralized.
- (3) All equipment, which has been in contact with chemicals, must be accompanied by a copy of the chemical product material Safety Data Sheet (SDS).
- (4) Failure to comply with the above instructions will result in equipment being returned to sender, freight collect, without service.

PARTS ORDERING INSTRUCTIONS

The complete model number and serial number of the pump must be furnished to insure prompt and accurate parts service. These numbers are found on the name plate (sample below) located on the side of the pump. Refer to **Section VII** for complete parts lists.

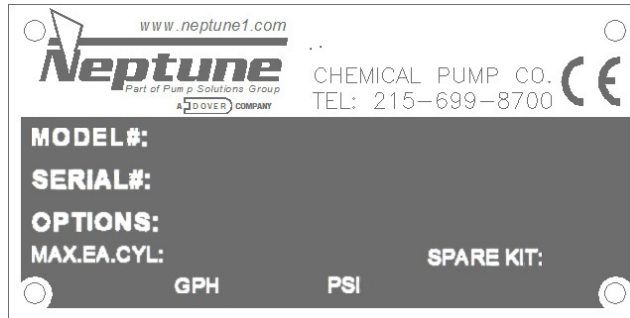

Send all orders or inquiries for parts to:

Email: order.neptune@psgdover.com

Website: www.psgdover.com/neptune.com

NOTE: PLEASE SUPPLY BOTH MODEL AND SERIAL NUMBERS.

SECTION II

INSTALLATION INSTRUCTIONS

1.0 GENERAL

- 1.0.1 When unpacking a pump or chemical feed system, be certain that no parts are thrown away. Examine the equipment for possible damage. If damage has occurred, file a claim with the common carrier within 24 hours. Neptune will assist in estimating the repair costs.
- 1.0.2 The “dia-PUMP” should be located so as to avoid an ambient temperature above 120°F, 50°C. Free air circulation is important when considering the location of the pump.
- 1.0.3 The “dia-PUMP” should be located on a level surface. Three mounting holes are provided to anchor the pump securely to the mounting surface. PVC head pumps must be mounted on three, one-inch spacers provided.
- 1.0.4 Neptune recommends a 4” to 6” inch clearance above mounting surface (on most models) to allow access to the Suction Valve. Please refer to model and valve location prior to installation.
- 1.0.5 All piping to the pump should be supported to prevent stress on the pump input and output fittings.
- 1.0.6 All fittings and connections must be airtight. Otherwise, pump suction capability will be reduced or lost.
- 1.0.7 Before connecting the pump, make sure that all fittings are completely clean by flushing thoroughly. Any foreign matter entering the pump can damage the internal parts and severely limit the life of the pump.
- 1.0.8 A “Y” STRAINER MUST BE INSTALLED IN THE SUCTION LINE OF THE PUMP TO INSURE AGAINST FOREIGN MATTER ENTERING THE PUMP. ALL SUCTION LIFT APPLICATIONS REQUIRE A FOOT VALVE STRAINER TO PREVENT LOSS OF PRIME, AND TO PREVENT FOREIGN MATERIAL FROM ENTERING THE PUMP.
- 1.0.9 Shut-off valves and unions should be placed in the suction and discharge lines to facilitate servicing the pump.
- 1.0.10 Care should be exercised when piping to PVC head pumps. In cases where vibration or stress is unavoidable, flexible connections should be used.
- 1.0.11 The electrical supply to the pump must match the motor name plate characteristics. The motor rotation is counterclockwise when viewed from the top of the motor, looking down on the pump. (See Figure 1).
- 1.0.12 Discharge Piping should be the same size or larger than the discharge connection. Suction Piping should be one size larger than the suction connection (1/2” pipe minimum). Limit the total length of the suction line to 3-4 feet suction lift or 6-7 feet flooded suction. Minimum bends, elbows, or other restrictions.

Important

On single phase integral motors, the rotation is set at the factory and must not be changed.

On three phase integral motors, rotation is determined by noting the fan rotation.

Pump body is grounded to earth. Ground connection **MUST** penetrate to bare metal. Ground to be clearly marked.

Check external pressure relief valve setting.

On some flange mounted motors, the motor rotation may be viewed by removing the cap on the side of the flange. There is no viewing port or coupling access on the close coupled flange mount motors. Rotation is checked by removing the oil fill plug and observing the gear. Correct rotation is indicated by the gear teeth moving downward away from the oil fill hole.

Please note Figure 1, indicating the correct rotation. (An arrow on the gear box also indicates proper rotation.) Operation with the incorrect rotation will damage the pump and motor.

Models 5003 and 5005 must be installed with a flooded suction. These models will not operate with suction lift.

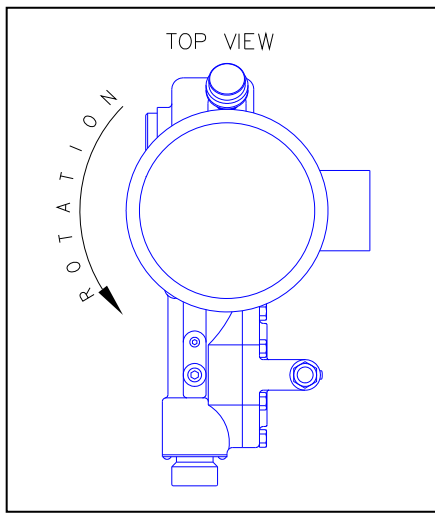

FIGURE 1

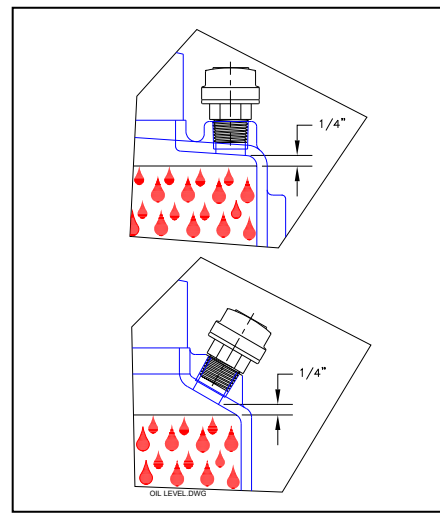

FIGURE 1A

1.013 Set capacity knob to zero and remove Air Bleed Plug from the top of Oil Chamber, refer to drawings HP-1102 (page 22) for Series 500 and drawing 5024 (page 28) for Series 500-A and 500-E for location of plug. Fill gear box and pump by pouring the hydraulic fluid supplied through the fill opening at the rear of the pump. Pour fluid in slowly until it has reached the correct level per Figure 1A. Do not over fill as this can cause damage to the motor.

Allow a few minutes for the hydraulic fluid work through the oil head and appear at the oil bleed plug. Recheck oil level. When air is purged, reinstall the Air Bleed Plug.

The hydraulic fluid supplied by Neptune is:

EP 68 Gear Oil, consult the parts listing in the back of this manual for the Neptune part number.

Heavier hydraulic fluid is supplied by Neptune for Hi Pressure Systems is EP SAE 90.

Alternate Oils For Standard	Mfg.	Alternate High Pressure Oils
Mobil Gear #626	Mobil Oil	Mobil Gear #629
Sun EP #68	Sun Oil	Sun Oil #220
Meropa #68	Texaco	Meropa #220
Mobil 1 0W30/5W30 for 5003/5005 Pumps only	Mobil Oil	

The 90-weight gear oil is used for high-pressure pumps using 1/2 horsepower motors or larger and rated for operation over 1000 PSI except 5003 and 5005 pumps which uses Mobil 0W30 synthetic oil. The 90-weight gear oil is also provided for the 500 pump models at all pressures.

2.0 SUCTION PIPING

2.0.1 The suction piping to the pump must be airtight. It is suggested that the suction piping be tested with low air pressure and a soap solution to assure that no leaks exist.

2.0.2 NEPTUNE RECOMMENDS THAT THE “dia-PUMP” BE OPERATED WITH A FLOODED SUCTION, AS THIS WILL FACILITATE START UP AND INCREASE THE SERVICE LIFE OF THE PUMP. It is, however, possible to operate the “dia-PUMP” with a suction lift of up to 5 feet, if necessary. A FOOT VALVE STRAINER must be used on this type of application. Models 5003 and 5005 require a flooded suction.

2.0.3 It is highly recommended that all solution tanks be furnished with a low level cut off switch or low-level alarm and cut off switch to prevent the pump from running dry. OPERATION AGAINST A DRY SYSTEM WILL CAUSE DAMAGE TO THE PUMP DIAPHRAGM AND REDUCE THE OPERATING LIFE OF THE PUMP.

2.0.4 The single, safest rule of thumb for selecting suction pipe size is to use the same size or one size **larger** than the pump suction connection (1/2” pipe minimum).

3.0 DISCHARGE PIPING

3.0.1 It is recommended that the “dia-PUMP” operate against a minimum discharge pressure of 50 psig. A back pressure spring is supplied loose with the pump. If 50 psig back pressure is not provided by the application, the back pressure spring should be installed on the pin under the discharge valve cap. Installation of the back pressure spring artificially creates a discharge head. (Refer to Figures II and III.)
Note: Spring is not provided in 500-E Series.

3.0.2 Take care to use piping suitable for the discharge pressure.

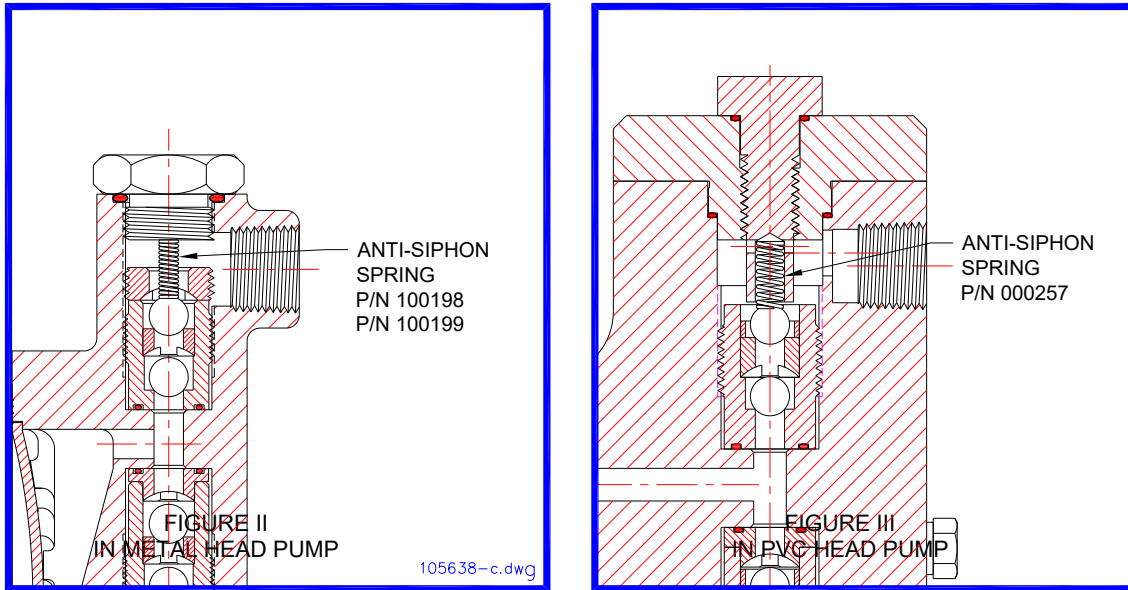

4.0 ADJUSTMENT OF INTERNAL RELIEF VALVE

4.0.1 All Neptune Series 500/5000 dia-PUMPs are supplied with an internal relief valve preset to 200 psi.

The internal relief valve is designed to protect the pump itself should a discharge pressure beyond the relief valve setting occur.

If a customer order specifies a relief valve setting above those indicated above, the specified setting will be set at the factory. All pumps are tagged with the relief valve setting used by the factory.

4.0.1 (Continued)

To protect the external piping system, it is recommended that a relief valve as manufactured by Neptune Chemical Pump Company, or equal, be placed in the discharge line of the pump. It is further recommended that this relief valve be piped into return of the tank with clear PVC tubing so that it can be determined if the solution is by-passing through the valve and returning to the tank, indicating a line blockage.

Drawing LN0004 illustrates the location of the Internal Relief Valve for Series 500 (FIG. #527 through #530). See drawing 5024 (page 28) for Series 500-A and 500-E.

The drawing shows a passage connecting the hydraulic fluid reservoir with the hydraulic fluid side of the diaphragm.

The passage is interrupted by the Relief Valve Poppet (FIG. #527) which is backed up by a Relief Valve Spring (FIG. #528).

If, during the pump operation, the pressure on the hydraulic fluid side of the pump exceeds the set pressure of the internal relief valve, the poppet is forced from its seat allowing the hydraulic fluid to flow back to the reservoir.

4.0.2 To reset the relief valve to a higher pressure, (the relief valve setting cannot be reduced because of design considerations) instructions are as follows:

4.0.21 Connect a test set-up as shown in Figure IV below.

4.0.22 Start and run the pump until all air is relieved from the discharge liquid (hand valve open).

4.0.23 Remove Relief Valve Plug (Fig. #530).

4.0.24 Close hand valve; pressure gauge will read the internal relief valve setting which should agree with the pressure setting on the tag if the pump is new. The desired setting is 100 psi above the operating pressure of the system into which the pump is injecting. Do not adjust lower than 200 psi.

4.0.25 To change the relief valve pressure setting, use the 3/16" Allen Wrench to adjust spring tension by turning Relief Valve Adjusting Screw (FIG. #529).

- (1) To increase pressure, turn Relief Valve Adjusting Screw (Fig. #529) in.
- (2) To decrease pressure, turn Relief Valve Adjusting Screw (Fig. #529) out.

4.0.26 After resetting or adjusting pressure, replace Relief Valve Plug (Fig. #530).

CAUTION

Never turn Relief Valve Adjusting Screw (Fig. #529) completely in.

Do not attempt to set the internal relief valve more than 200psi in excess of name plate rating.

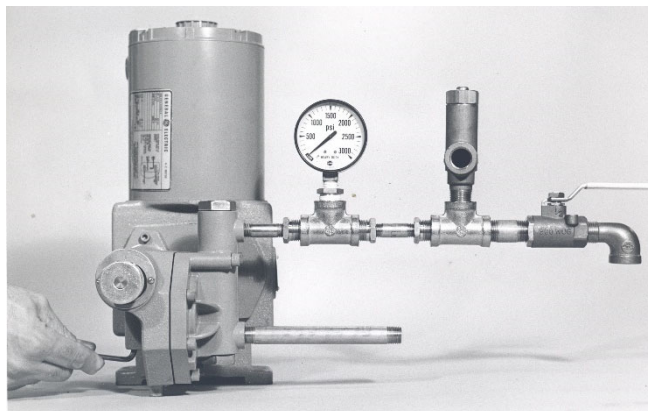

FIGURE IV

4.0.3 Parts required to test or adjust Relief Valve Pressure.

1 Pc.	1/2" Pipe Nipple 6" Long
2 Pcs.	1/2" Pipe Nipple 2" Long
1 Pc.	1/2" Hand Valve
2 Pcs.	1/2" Tee
1 Pc.	1/2" NPT X 1/2" Hose (Fitting)
1 Pc.	1/2" Hose, As Required
1 Pc.	1/2" Pressure Gauge (Minimum Gauge Pressure 500 psi)
1 Pc.	Allen Wrench 3/16"
1 Pc.	External Relief Valve (optional)

NOTE

The above parts must have a working pressure rating above the required set pressure.

5.0 INSTALLATION OUTDOORS

The "dia-PUMP" is a totally enclosed pump which can be used outdoors or indoors. When installed outdoors, make sure that the pump is protected against extremes of nature as follows:

- 5.0.1. Running of the pump when exposed to tropical sunshine, with ambient temperature above 100°F, 38°C would cause excessive oil and motor temperatures. The pump should be shaded and located in such a way as to permit a high degree of air circulation.
- 5.0.2 Under cold conditions, the pump should be insulated and a heater should be supplied in order to maintain the hydraulic fluid at an ambient temperature above 30°F, -1°C. Heat may be provided by a 100 watt bulb or a heater tape, etc.

6.0 START-UP PROCEDURE (FLOODED SUCTION)

The following start-up procedure is complete and does repeat instructions on filling the gear box and pump.

- 6.0.1 The gear box should be filled with hydraulic fluid per the instructions in paragraph 1.0.12. Let the pump stand for 30 minutes and then recheck the fluid level. Be certain that pump discharge lines are open.
- 6.0.2 Confirm that the liquid head is flooded, and no air remains per the following paragraphs. Pumps should **not** be running. Wear appropriate protective gear when performing any step that involves contact with the chemical.

6.0.2.1 SERIES 500 and 500-A METAL HEAD

Make certain that pumping chamber is flooded, and air is purged by loosening Discharge Valve Cap (FIG. #536 on page 22) approximately 2 to 3 turns and allowing solution to appear. Then, tighten discharge valve cap. This procedure will also allow air to vent from the pumping chamber. THE "dia-PUMP" WILL NOT FUNCTION IF AIR IS TRAPPED IN THE HYDRAULIC FLUID OR LIQUID PUMP CHAMBERS.

6.0.2.2 SERIES 500 AND 500-A PVC HEAD

PVC Head Pumps –Discharge Valve Cap (P/N 000256 on page 23) is loosened by loosening Valve Cap Screws (P/N 100250).

6.0.2.3 SERIES 500-E (See page 26)

6.0.3 Follow the procedure below:

1. Make certain that the suction line, liquid end and discharge cartridge chamber are filled with water or system fluid.
2. Set the capacity control knob to approximately 30-40% of maximum capacity.
3. On initial start-ups: Check for proper motor rotation (Refer to Paragraph 1.0.11). Run the pump for 10-20 seconds, then stop for 20-30 seconds. Repeat a few times. During these short runs, listen for any abnormal motor or crank noises, and if present, refer to Trouble Shooting Chart.

4. On initial gearbox fill or after replacing hydraulic fluid, run pump for one-half to one hour to warm up oil and allow air bubbles to dissipate. Check discharge line for indication of flow.
 5. Once discharge flow is observed proceed to paragraph number 6; if no flow, repeat steps 3 and 4.
 6. Increase capacity adjustment setting to 70% of maximum capacity and operate for 10-20 minutes.
 7. Reduce capacity adjustment setting to 30-40% of maximum capacity and operate for several minutes, then increase capacity adjustment back to 100% for approximately 10 minutes. Repeat several times to insure that the air is bled from the hydraulic fluid side and the liquid side.
- 6.0.4 The pump is now ready for “on line” service. Calculate what the desired capacity as a percentage of either the maximum capacity rating on the pump data plate, or the nominal capacity at the required system pressure.

7.0 START-UP PROCEDURE (SUCTION LIFT) SERIES 500 AND 500-A.

(See page 26 for SERIES 500-E) MODELS 5003, 5005 AND 510 REQUIRE A FLOODED SUCTION.

- 7.0.1 If the “dia-PUMP” is to be used where suction lift is required, A FOOT VALVE STRAINER MUST BE INSTALLED on the end of the suction line. A pipe tee is installed on the top end of the suction line with one leg to the pump suction, one leg to the suction line and one leg pointing straight up and plugged. Remove plug and fill piping assembly with liquid. Replace plug. Start pump and follow procedure per Paragraph 6.0.3.

Use the following procedure only if required:

- 7.0.2 Remove Discharge Valve Cap (FIG. #536). Then, using Allen wrench provided, remove Discharge Valve Nut (FIG. #543). The Discharge Valve Nut (FIG. #543) is stamped with the letter “T” to indicate the face which should be installed toward the top on reassembly. Finally, remove Discharge Valve Cartridge (FIG. #539) using special blade provided. Fill the pumping chamber with liquid to check operation of the suction valve. Reinstall / replace parts and then follow instructions per Section II, Paragraph 6.0.3. Repeat entire procedure if pump loses prime or runs dry. (See Figures VI and VII.)

NOTE

PVC Head Pumps (Refer to page #23) – Remove Discharge Valve Cap (P/N 000256) by removing Valve Cap Screws (P/N 100250). Next, remove Discharge Valve Cartridge (P/N 000259) using special round lug tool provided. Fill pumping chamber with liquid to check operation of the suction valve. Reinstall / replace parts and then follow instructions per Section II Paragraph 6.0.3. (Refer to Figure VII.)

CAUTION

Do not over tighten PVC valves as the PVC material is not able to withstand excessive force and can fail. Teflon® paste is an excellent thread lubricant and may be applied.

8.0 START-UP AFTER SUCTION HAS RUN DRY

In applications where the suction tank does not have a low level cut-off interconnected into the pump motor circuit, the pump may occasionally run dry. THIS MUST BE AVOIDED BECAUSE DAMAGE TO THE PUMP CAN RESULT AND THE SERVICE LIFE WILL BE SIGNIFICANTLY REDUCED WHEN THE PUMP IS ALLOWED TO RUN WITH A DRY LIQUID END.

Before restarting a pump that has run dry and which has not damaged itself, follow the procedure in Paragraph 6.0 through 6.0.3 of Section II, except it is not necessary to warm up the oil.

®Teflon – A registered trademark of the DuPont Company.

SECTION III

NORMAL MAINTENANCE AND DISASSEMBLY INSTRUCTIONS

9.0 MAINTENANCE

CAUTION - Ensure all operators are properly trained and employ safe operating and maintenance practices. Operator error may cause process liquid to expel through the head joints and/ or piping.

Under normal conditions, the “dia-PUMP” does not require any significant amount of maintenance. It is advised that periodic visual observations be made of the oil level. See Page 5 (Figure 1A) for correct oil level. The liquid end of the pump should also be inspected for leakage. These observations should be made regularly, at least every 48 hours.

Recommended Maintenance Schedule
Weekly Interval
<ul style="list-style-type: none">• Check oil level
<ul style="list-style-type: none">• Check for leaks
<ul style="list-style-type: none">• Check ground connection for corrosion
<ul style="list-style-type: none">• Clean pump surfaces and surrounding area of dust and debris
First 250 hours of operation
<ul style="list-style-type: none">• Change oil
Every 4000 hours or six months
<ul style="list-style-type: none">• Change oil
<ul style="list-style-type: none">• Clean inlet piping strainer & check external pressure relief valve
<ul style="list-style-type: none">• Replace worm shaft oil seal
<ul style="list-style-type: none">• If equipped, check coupling insert. Replace if necessary.
<ul style="list-style-type: none">• Tighten all fasteners
Annual
<ul style="list-style-type: none">• Clean check valves. Replace O-rings.
<ul style="list-style-type: none">• Replace diaphragm
<ul style="list-style-type: none">• If equipped, replace coupling insert.
<ul style="list-style-type: none">• Replace rolling element bearings
<ul style="list-style-type: none">• Replace O-rings
<ul style="list-style-type: none">• Replace check valves
<ul style="list-style-type: none">• For Low Profile Flange style (-FALP), Apply Anti-seize at motor shaft and gear shaft adapter.

10.0 REMOVAL OF VALVE CARTRIDGES (See page 26 for SERIES 500-E; Page 29 for 500-VS)

The “dia-PUMP” incorporates a unique check valve design whereas the discharge and suction piping NEED NOT be disturbed in order to service the valve cartridges.

Should the valves need cleaning, remove as follows:

- 10.0.1 Suction Valve: Remove Suction Valve Cap (FIG. #550) and using Allen Wrench provided, remove Suction Valve Cartridge (FIG. #544).

NOTE for PVC Head Pumps

Remove Suction Valve Cap (P/N 000256) by removing the Valve Cap Screws (P/N 100250) and remove Suction Valve Cartridge (P/N 000259) using the special round lug tool provided. Caution: PVC is fragile – do not use excessive force.

- 10.0.2 For removal of discharge valve, refer to instruction in Section II, Paragraph 7.0.2.

- 10.0.3 Please refer to Figures VI and VII showing valve cartridge removal.

11.0 CLEANING OF VALVE CARTRIDGES

- 11.0.1 The valve cartridge is a complete and integral unit and should not be disassembled for cleaning. If the valves are found to be worn and in need of replacement, an entire valve cartridge, either suction or discharge, should be ordered. The suction valve is the longer of the two valve cartridges.

- 11.0.2 To clean the valve cartridges, soak in strong detergent and then blow dry with compressed air.

12.0 REPLACING OF VALVE CARTRIDGES (See page 25 for SERIES 500-ER)

- 12.0.1 Be certain that the Valve Seat O-Ring (FIG. #549 for Metal Head Pumps, P/N 100185 for PVC Head Pumps) is removed with the valve and that no other foreign matter is in the valve cavity. Use a small amount of grease to hold the o-ring in the groove in the end of the valve cartridge on reassembly.

Reverse the procedure used to remove the valve cartridge. Do not over-tighten valve cartridge. Firm tightening is enough to cause the O-Ring to seal.

12.0 REPLACING OF VALVE CARTRIDGES (Continued)

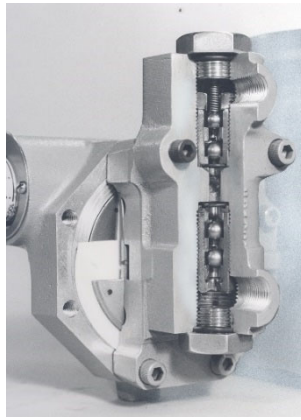

FIGURE V
CUT-AWAY VIEW OF VALVE SECTION, METAL HEAD PUMP

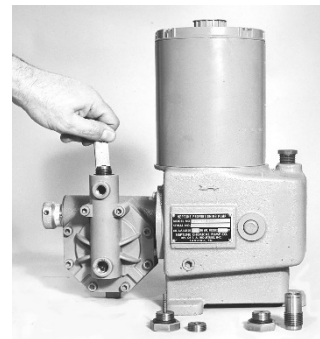
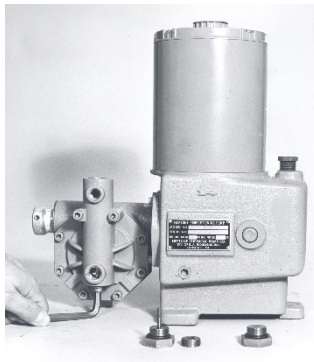
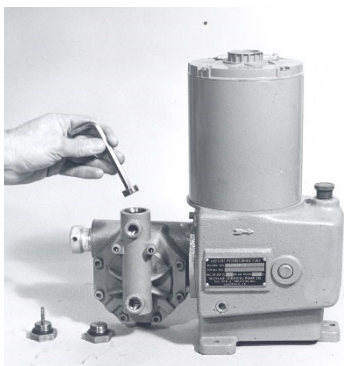

FIGURE VI
VALVE CARTRIDGE REMOVAL, METAL HEAD PUMP

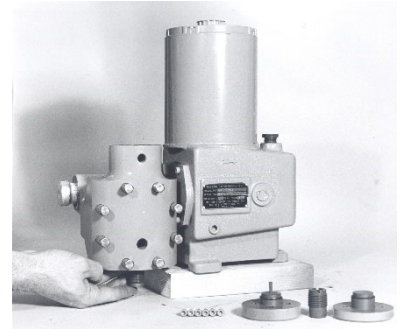
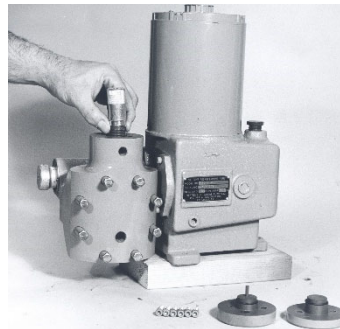
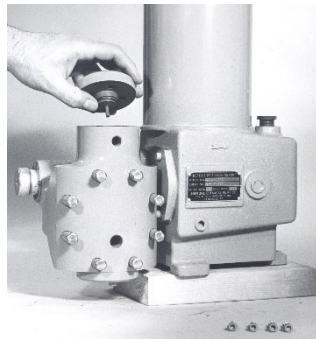
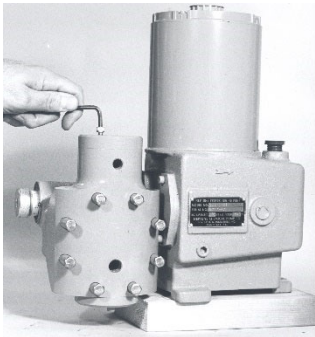

FIGURE VII
VALVE CARTRIDGE REMOVAL, PVC HEAD PUMP

13.0 PROCEDURE FOR REPLACING CONTROL ROD O-RING (fig. #517) AND SEALING PLATE O-RING (FIG. #516).

Refer to Figure VIII

1. Remove Drain Plug (FIG. #510) and drain hydraulic fluid.
2. Remove Indicator Plate (FIG. #520) by removing two holding screws.
3. Remove control rod assembly with Control Rod (FIG. #'s 515, 523,524) attached, by turning counterclockwise and pulling out.
4. Insert 11/16" Hex Socket onto the Sealing Nut (FIG. #526) and screw out of pump in a counterclockwise direction. Then, remove Sealing Plate (FIG. #518) using a small brass hook to pull loose.

5. Replace Control Rod O-Ring (FIG. #517) and Sealing Plate O-Ring (FIG. #516).
6. Take care when replacing Sealing Plate, (FIG. #518) to not damage the Sealing Plate O-Ring (FIG. #516).
7. Replace all parts and fill pump with hydraulic fluid per previous instructions.
8. Follow start-up procedure as if starting a new pump.

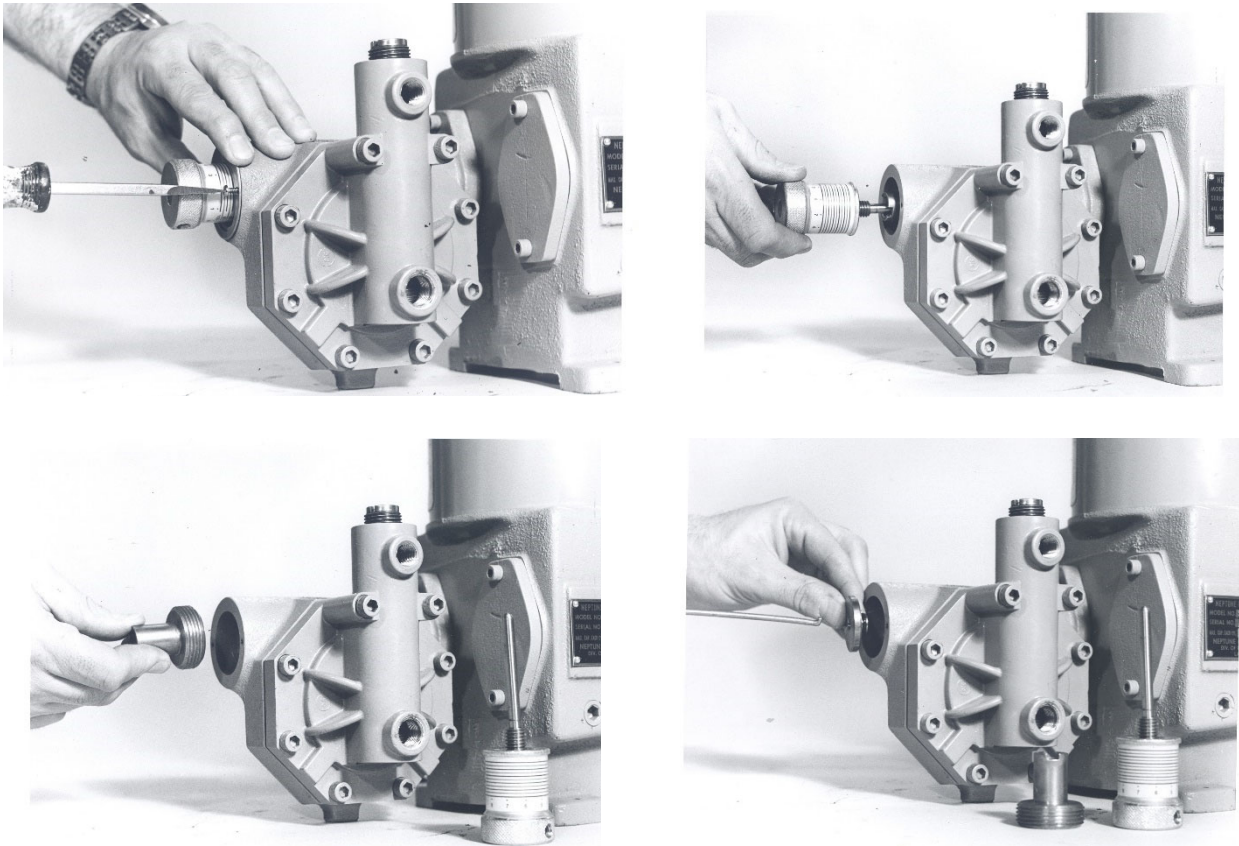

FIGURE VIII
REMOVAL OF CONTROL ROD ASSEMBLY

14.0 REMOVAL OF PUMP HEAD AND REPLACEMENT OF DIAPHRAGM (REFER TO FIGURES IX AND X)

- 14.0.1 Remove Drain Plug (FIG. #510), and drain hydraulic fluid.
- 14.0.2 Remove Long and Short Pump Head Bolts [(FIG. #'s 551 and 552) or (P/N 101135 and P/N 101136) on PVC pumps.] Lift Pump Head [(FIG. #535) or (P/N 000255, P/N 000258) on PVC pump] away from pump.
- 14.0.3 Remove and examine Teflon Diaphragm (FIG. #533). Remove and examine the Liquid Side Diaphragm Backup Place [(FIG. #532) or (P/N 000254, 100245) on PVC pumps.] Replace with new part, if required. When replacing the Teflon diaphragm, be certain to line it up properly with the sealing grooves.
- 14.0.4 To reassemble, reverse the above procedure. Reassembly is facilitated by laying the pump on its side. Be certain to tighten all bolts evenly. Tighten to 25 ft. lbs. (15ft. lbs. On PVC pump).
- 14.0.5 Start up pump by following Start-Up Procedure per Section II Paragraph 1.0.12 and 6.0.3.

14.0 REMOVAL OF PUMP HEAD AND REPLACEMENT OF DIAPHRAGM (Continued)

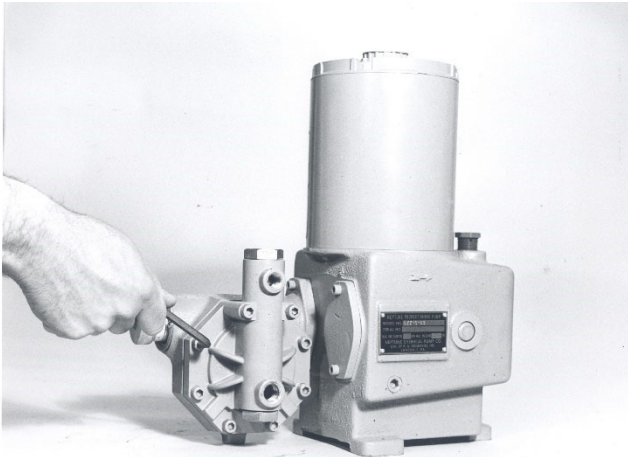

FIGURE IX

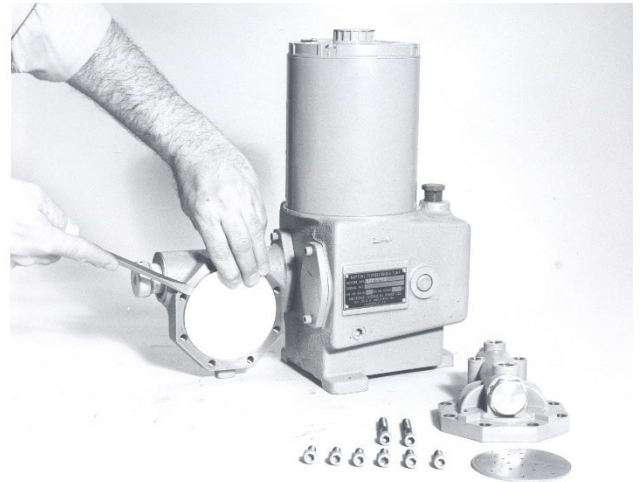

FIGURE X

15.0 REMOVAL OF MOTOR FROM STANDARD "dia-PUMP" (REFER TO FIGURE XI)

15.0.1 Disconnect all wires leading to the motor.

15.0.2 Remove Drain Plug (FIG. #510) and drain hydraulic fluid from pump.

15.0.3 Remove the fan cover and fan if the motor is a TEFC type. Remove retaining bolts from the top of the motor. These bolts are threaded directly into the Pump Gear Box (FIG. #500).

15.0.4 Turn case of motor gently to break silicone seal between motor casing and Pump Gear Box (FIG. #500). Tilt motor slightly forward and remove housing and remove internal part.

15.0.5 To replace motor, clean machined surface at top of Gear Box (FIG. #500) and apply silicone sealer. Place motor back in position generally reversing the disassembly procedure.

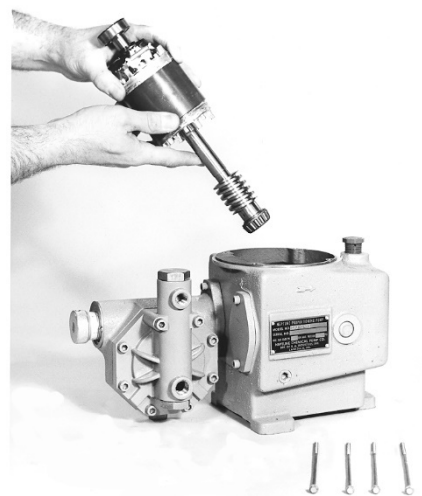
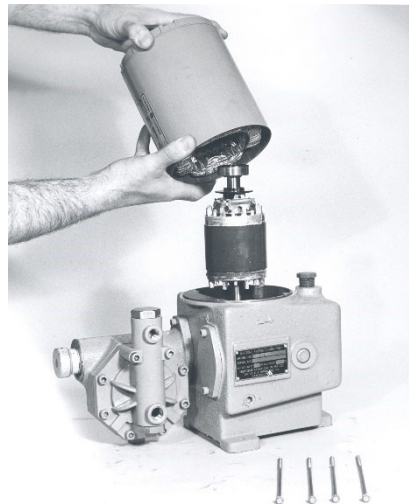
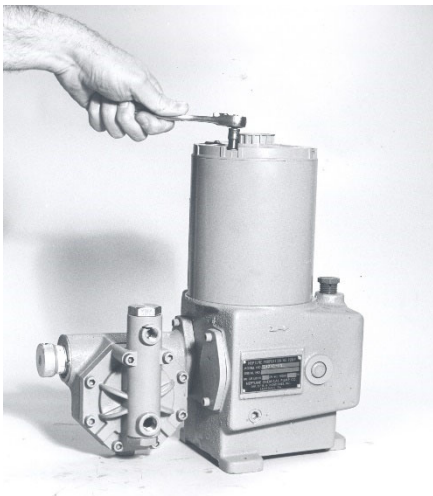

FIGURE XI

SECTION IV

MOTOR OPERATING CONDITIONS

- 16.0 The Standard Series 500/5000 "dia-PUMP" is supplied with a 1/3 HP or 1/2 HP/single phase/totally enclosed fan cooled motor as an integral part of the pump itself.

The normal temperature rise for this motor is 40°C above ambient temperature and thus, it might appear that the motor is operating at a higher than normal temperature. This situation is normal and should not cause concern.

Due to the high motor surface temperature (80°C), as a precaution to avoid burning skin, it is recommended to avoid touching the pump during operation. After shutting off pump, let the pump rest for 5 minutes before touching the motor.

As a precaution against motor overheating, it is recommended that the pump be located where adequate ventilation is available. It is also highly RECOMMENDED THAT A MOTOR STARTER WITH THE PROPER OVERLOAD PROTECTION BE SUPPLIED AS AN ADDITIONAL SAFETY DEVICE.

The Standard Series 500/5000 "dia-PUMP" (1/3HP/1/115V/60C/TEFC) motor is supplied with built-in thermal protection. Automatic overload is provided on all pumps with standard motor with serial numbers higher than 9600-78D.

Should an overload occur on a standard motor unit which is not protected by a motor starter or on such a unit where the starter has failed, the motor will shut down automatically. It will take approximately ½ hour for the automatic thermal overload switch to reset itself.

SECTION V TROUBLESHOOTING CHART

SYMPTOMS	CAUSES	REMEDIES
1. Pump Motor Will Not Operate.	A. Blown Fuse.	A. Check for short circuit or overload.
	B. Open thermal overload device in starter or motor.	B. Reset.
	C. Low liquid level in tank (where low level cut-off is used).	C. Fill tank.
	D. Broken wire.	D. Locate and repair.
	E. Low voltage.	E. Check for too light wiring.
	F. Oil "frozen" in pump.	F. Thaw out.
*2. Pump Does Not Deliver Rated Capacity	A. Starved suction.	A. Replace suction piping with larger size, or increase suction head.
	B. Leaky suction piping.	B. Pressure test, repair or replace defective piping.
	C. Excessive suction lift.	C. Rearrange equipment location to reduce suction lift.
	D. Liquid too close to boiling point.	D. Lower temperature or increase suction head pressure.
	E. Air or gas trapped in oil or pumpage.	E. Decrease capacity to 20% for 5 mins., then increase to 100% for 5 mins.
	F. Worn or dirty valves or seats, or both.	F. Clean or replace.
	G. Viscosity of liquid too high (CPS).	G. (1) Reduce viscosity by heating or other means; (2) Increase size of suction piping; (3) Increase suction pressure
	H. Insoluble materials settling out, or crystallization of saturated solution.	H. Check solution strength. Flush and clean solution tank periodically. Suction connection should be 2 to 4" from bottom of solution tank.
	I. Low discharge pressure.	I. A minimum discharge pressure of 50 psi is required to insure proper capacity control.
	J. Capacity adjustment set above 100% capacity mark.	J. Reposition adjustment knob to 100% mark.
	K. Air in hydraulic or chemical systems.	K. Bleed system.

SYMPTOMS	CAUSES	REMEDIES
	L. No foot valve strainer.	L. Install one.
*3. Pump delivers erratically.	A. Leaky suction line. B. Worn or dirty valves or seats, or both. C. Excessive excursion of ball from valve seats (indicated by ball chatter). D. Liquid too close to boiling point. E. Leaky internal or external relief valve.	A. Repair or replace piping. B. Clean or replace cartridges. C. Replace cartridges. D. Reduce temperature or raise suction pressure. E. Repair or replace relief valve.
4. Motor Overheats Thermal Overload Activates	A. Overload caused by operating pump beyond rated capacity.	A. Check operating pressure against pump manufacturer's data plate maximum rating.
5. Noisy Operation (1) In Pump	A. Pump Valves.	A. Valves must move to open and close, and they will make a clicking noise as they operate. These noises are sometimes amplified by natural resonances in the piping system. They are usually indications of normal valve functioning.
(2) In Gear Reducer	A. Pounding noise at high discharge pressure.	A. Fluid compressibility causes reversal of load on gears at end of pressure stroke. Not considered detrimental.
6. Improper Oil Level in Reservoir.	A. Increases and overflows.	A. Flexible diaphragm punctured by foreign material – replace diaphragm. Clean and flush hydraulic system at once.
7. Pump Delivery is Not Adjustable	A. System pressure too low.	A. Install back-pressure spring, provided, into discharge cartridge. B. Install Back-pressure valve.
8. Pump Does Not Develop Required Pressure	A. Internal relief valve leaking. B. Internal relief valve being actuated.	A. Check setting as per pressure change procedure, Paragraph 4.0. B. System pressure exceeds relief valve set pressure. Refer to Paragraph 4.0 for adjustment procedure.

* Symptoms 2 and 3 ---- A Diaphragm may need replacing.

SECTION VI
SEE ELECTRIC STROKE CONTROL INSTRUCTION MANUAL P/N ZL106738
FOR PUMPS FURNISHED WITH OPTIONAL ELECTRIC STROKE CONTROL.

17.0 Typical Drawing of the Neptune dia-PUMP with Electric Stroke Control shown below.

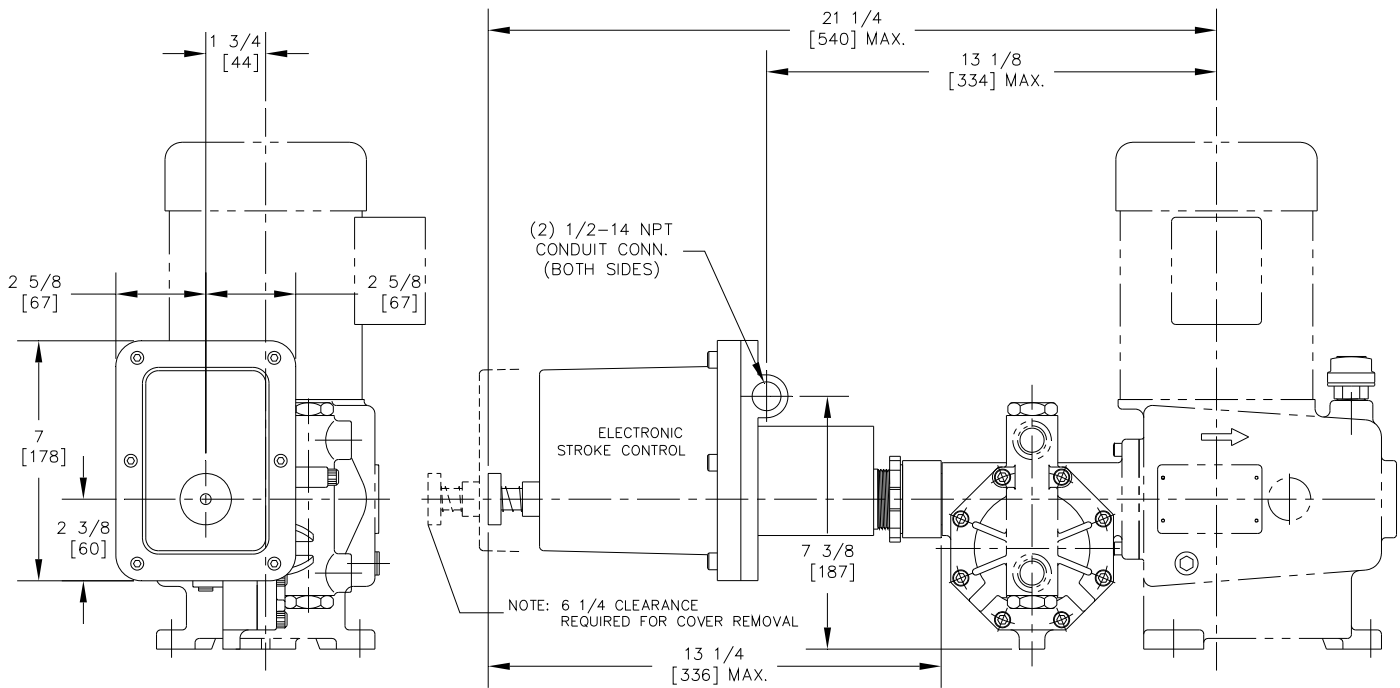

**SECTION VII PARTS LIST
SERIES 500 AND 500-A PUMP PARTS**

FIG. NO.	DESCRIPTION	QTY.	PART NO.
500	Gear Box*	1	000162
5005	Worm Gear 37 SPM*	1	000164
	Worm Gear 72 SPM*	1	000166
	Worm Gear 117 SPM*	1	000163
	Worm Gear 144 SPM*	1	002818
	Worm Gear 175 SPM*	1	000165
502	Connecting Rod	1	000167
503	Gear Shaft*	1	106305
506	Worm 37 SPM	1	000170
	Worm 72 SPM	1	000172
	Worm 117 SPM	1	000169
	Worm 144 SPM	1	002817
	Worm 175 SPM	1	000171
507	Bearing Cup	1	100179
508	Bearing Cone	1	100180
509	Worm Spring Pin	1	100181
510	Drain Plug	1	100182
511	Connecting Rod Pin	1	100183
512	Fill Plug	1	000191
513	Pump Body, Right Hand		
	1/2" Small Cavity††	1	000180
	1/2" Standard Cavity††	1	000178
	11/16" Standard Cavity††	1	000177
	1-1/16" Standard Cavity††	1	000176
	1-3/16" Standard Cavity††	1	003232
	Pump Body, Left Hand		
	1/2" Small Cavity††	1	000179
	1/2" Standard Cavity††	1	000175
	11/16" Standard Cavity††	1	000174
	1-1/16" Standard Cavity††	1	000173
	1-3/16" Standard Cavity††	1	003235
514	Piston 1/2"	1	000181
	Piston 11/16"	1	000182
	Piston 1-1/16"	1	000183
	Piston 1-3/16"	1	003234
515	Control Rod	1	000184
516	Sealing Plate O-Ring 1/2"	1	100184
	Sealing Plate O-Ring 11/16"	1	100185
	Sealing Plate O-Ring 1-1/16"	1	100186
	Sealing Plate O-Ring 1-3/16"	1	100244
517	Control Rod O-Ring	1	100188
518	Sealing Plate 1/2"	1	000185
	Sealing Plate 11/16"	1	000186
	Sealing Plate 1-1/16"	1	000187
	Sealing Plate 1-3/16"	1	003233
	Capacity indicating scale	1	100192
	Capacity indicating scale 5003	1	104802
	Capacity indicating scale 5005	1	104799

FIG. NO.	DESCRIPTION	QTY.	PART NO.
519	Control Rod Spring Pin	1	100189
520	Indicator Plate	1	000188
521	Indicator Plate Screws	2	100190
522	Control Knob Set Screw	1	100191
523	Control Rod Positioner	1	000189
	Control Rod Positioner 5003	1	004839
	Control Rod Positioner 5005	1	004834
524	Control Knob	1	002071
	Control Knob for 5003	1	004841
	Control Knob for 5005	1	004836
526	Sealing Nut	1	002069
	Sealing Nut for 5003	1	004840
	Sealing Nut for 5005	1	004835
527	Relief Valve Poppet Except Model 547	1	000193
	Relief Valve Poppet Model 547 Only	1	003531
528	Relief Valve Spring	1	100193
	Relief Valve Spring-High Pressure Denoted by "HP" in Model No. After Material Code-Example: 515-S-N3HP	1	106319
529	Relief Valve Adjusting Screw	1	105164
530	Relief Valve Plug	1	108043
531	Oil Side Backup Plate		
	Small Diameter Models 500, 5003, 5005††	1	000197
	Standard Diameter Except Models 53X and 54X††	1	000194
	Standard Diameter Models 53X and 54X††	1	003946
533	Teflon Diaphragm		
	Small Cavity ††	1	000231
	Standard Cavity ††	1	000200
534	Pump Body Cap Screws	2	100293
538	Valve Cap O-Rings	2	100200
	Valve Cap O-Rings-Teflon	2	100213
549	Valve Seat O-Rings	2	100204
	Valve Seat O-Rings-Teflon	2	100203
553	Pipe Plug	1	100210
554	Cover Plate	1	000229
555	Cover Plate Screws	2	100211
556	Std. Motor Assembly 18 SPM**	1	003618
	Std. Motor Assembly 37 SPM**	1	002400
	Std. Motor Assembly 72 SPM**	1	002401
	Std. Motor Assembly 117 SPM**	1	002402
	Std. Motor Assembly 144 SPM**	1	002836
	Std. Motor Assembly 175 SPM**	1	002407
557	Hydraulic Fluid (2 qts.) ISO68	1	003089
	Hydraulic Fluid (2 qts.) SAE90	1	002372
	Hydraulic Fluid (1 qt.) SAE 0W30 Synthetic	1	104807
590	Gasket or Sealer	1	106290
591	Gasket or Sealer	2	106291
592	Gasket or Sealer	1	131962
5002	Shaft Retainer Assembly*	1	002722
5004	Thrust Washers	3-4	100252
5025	Shaft Retainer Screws	3	100254
5699	Knob Friction O-Ring	1	100417

STD motor assemblies include figure numbers 506, 508, 509.

††Models 5003, 5005, 500 are small cavity. All others are standard cavity.

Right hand pump body is standard on all Simplex Pumps.

* Items not to be used on 500-A pumps (page 2)

** Includes Part Nos. 506, 508 and 509.

1/3-1-115-60-TEFC-CAP-48Y.

PARTS FOR PUMP WITH METAL HEADS

FIG NO.	DESCRIPTION	QTY.	N3 PART NO.	N4 PART NO.
532	Diaphragm Back Up Plate Liquid Side (Standard Cavity)	1	000195	000196
	Diaphragm Back Up Plate Liquid Side (Small Cavity)	1	000198	000199
535	Liquid Head (Standard Cavity)	1	000202	000203
	Liquid Head (Small Cavity)	1	000205	000206
536	Discharge Valve Cap	1	002073	002072
537	Anti-Siphon Spring 18, 37, 72 or 117 SPM Pumps	1	100198	100199
539	Discharge Valve Cartridge	1	000209	000210
543	Discharge Valve Nut	1	000215	000216
544	Suction Valve Cartridge	1	000217	000218
550	Suction Valve Cap	1	000207	000208
551	Short Pump Head Bolts	6	100206	100206
552	Long Pump Head Bolts	2	106184	106184

SPARE PARTS KIT (N3 CONSTRUCTION) MODELS 500 THROUGH 547, 5003 & 5005

FIG. NO.	DESCRIPTION	QTY.	PART NUMBER	
539	Discharge Valve Cartridge	1	000209	KIT NUMBER 002712 DUPLEX PUMPS REQUIRE 2 KITS
544	Suction Valve Cartridge	1	000217	
549	Valve Seat O-Ring	4	100204	
538	Valve Cap O-Ring	4	100200	
533	Diaphragm (Models 500, 5003 & 5005 Only)	1	000231	
533	Diaphragm (All Other Models)	1	000200	
517	Control Rod O-Ring	2	100188	
516	Sealing Plate O-Ring (Models 500/5005/510/515)	2	100184	
516	Sealing Plate O-Ring (Models 520/522/525/527)	2	100185	
516	Sealing Plate O-Ring (Models 530/532/535/537/538)	2	100186	
516	Sealing Plate O-Ring (Models 547)	2	100244	

SPARE PARTS KIT (N4 CONSTRUCTION) MODELS 500 THROUGH 547, 5003 & 5005

FIG. NO.	DESCRIPTION	QTY.	PART NUMBER	
539	Discharge Valve Cartridge	1	000210	KIT NUMBER 002713 DUPLEX PUMPS REQUIRE 2 KITS
544	Suction Valve Cartridge	1	000218	
549	Valve Seat O-Ring	4	100204	
538	Valve Cap O-Ring	4	100200	
533	Diaphragm (Models 500, 5003 & 5005 Only)	1	000231	
533	Diaphragm (All Other Models)	1	000200	
517	Control Rod O-Ring	2	100188	
516	Sealing Plate O-Ring (Models 500/5005/510/515)	2	100184	
516	Sealing Plate O-Ring (Models 520/522/525/527)	2	100185	
516	Sealing Plate O-Ring (Models 530/532/535/537/538)	2	100186	
516	Sealing Plate O-Ring (Models 547)	2	100244	

SPARE PARTS KIT (N5 CONSTRUCTION) MODELS 500 THROUGH 547, 5003 & 5005

FIG. NO.	DESCRIPTION	QTY.	PART NUMBER	
P-539-C	Discharge Valve Cartridge	1	000259	KIT NUMBER 002714 DUPLEX PUMPS REQUIRE 2 KITS
P-544-C	Suction Valve Cartridge	1	000262	
P-549-C	Valve Seat O-Ring	4	100185	
P-538-C	Valve Cap O-Ring	4	100244	
533	Diaphragm (Models 500, 5003 & 5005 Only)	1	000231	
533	Diaphragm (All Other Models)	1	000200	
517	Control Rod O-Ring	2	100188	
516	Sealing Plate O-Ring (Models 500/5005/510/515)	2	100184	
516	Sealing Plate O-Ring (Models 520/522/525/527)	2	100185	
516	Sealing Plate O-Ring (Models 530/532/535/537/538)	2	100186	
516	Sealing Plate O-Ring (Models 547)	2	100244	
P-571-C	Vent Plug O-Ring	2	100080	

PARTS FOR PUMPS WITH MOTOR FLANGE ADAPTER, (REFER TO PARTS DRAWING 000911 ON PAGE 24)

FIG. NO.	DESCRIPTION	QTY.	PART NUMBER
507	Bearing Cup	1	100179
508	Bearing Cone	2	100180
558	Motor Flange Adapter	1	000227
559	Worm Shaft with Retaining Ring attached (Part #107952)	1	000228
560	Lovejoy Coupling	1	100053
561	Oil Seal	1	100214
562	Adapter to Gear Box Bolts	4	100215
563	Adapter to Motor Bolts	4	100216
564	Lock Washer	4	100217
565	Coupling Key	2	100218
566	Lock Washers	4	100219
509	Spring Pin	1	100181

PARTS UNIQUE TO PUMPS SUPPLIED WITH NEPTUNE PNEUMATIC STROKE CONTROL

FIG. NO.	DESCRIPTION	QTY.	PART NUMBER
570	Control Rod "P"	1	000273
571	Control Mount	1	000274
572	Short Mounting Bolt	3	100259
573	Plexiglass Shell	1	000275
576	Piston	1	000276
578	Range Spring, 3-15 psi (9 psi Span) Standard	1	100260
578	Range Spring, 3-9 or 9-15 psi (6 psi Span)	1	100261
578	Range Spring, 5-25 psi (20 psi Span)	1	100262
578	Range Spring, 3-27 psi (24 psi Span)	1	100263
579	Housing	1	000277
580A	Moore 73N Control Valve – Forward Acting	1	100265
580B	Moore 73N Control Valve – Reverse Acting	1	100266
581	Retainer Bolt	1	100267
583	Pneumatic Diaphragm	1	100268
584	Control Rod Adapter	1	000280
585	Control Spring Pin	1	100269
586	Long Mounting Bolt	3	100270
587	Operating Spring	1	100271
589	Retaining Plate and Stop Bushing	1	000281

PARTS UNIQUE TO PUMPS SUPPLIED WITH "FALP" (REFER TO PARTS DRAWING FALP ON PAGE 24)

FIG. NO.	DESCRIPTION	QTY.	PART NUMBER
562	Adapter to Gearbox Bolts	4	100215
563	Adapter to Motor Bolts	4	100216
564	Lock Washers	4	100217
566	Lock Washers	4	100219
611	Motor Flange Adapter	1	004157
612	Motor Worm Shaft	1	004156
613	Wave Spring	1	107599
614	Bearing	1	106180
615	Retaining Ring	1	106593

**SECTION VII
PARTS ORDERING INSTRUCTIONS**

Note: For Prompt entry of parts orders; your order must include both model number and serial number.

Drawing LN0004_A

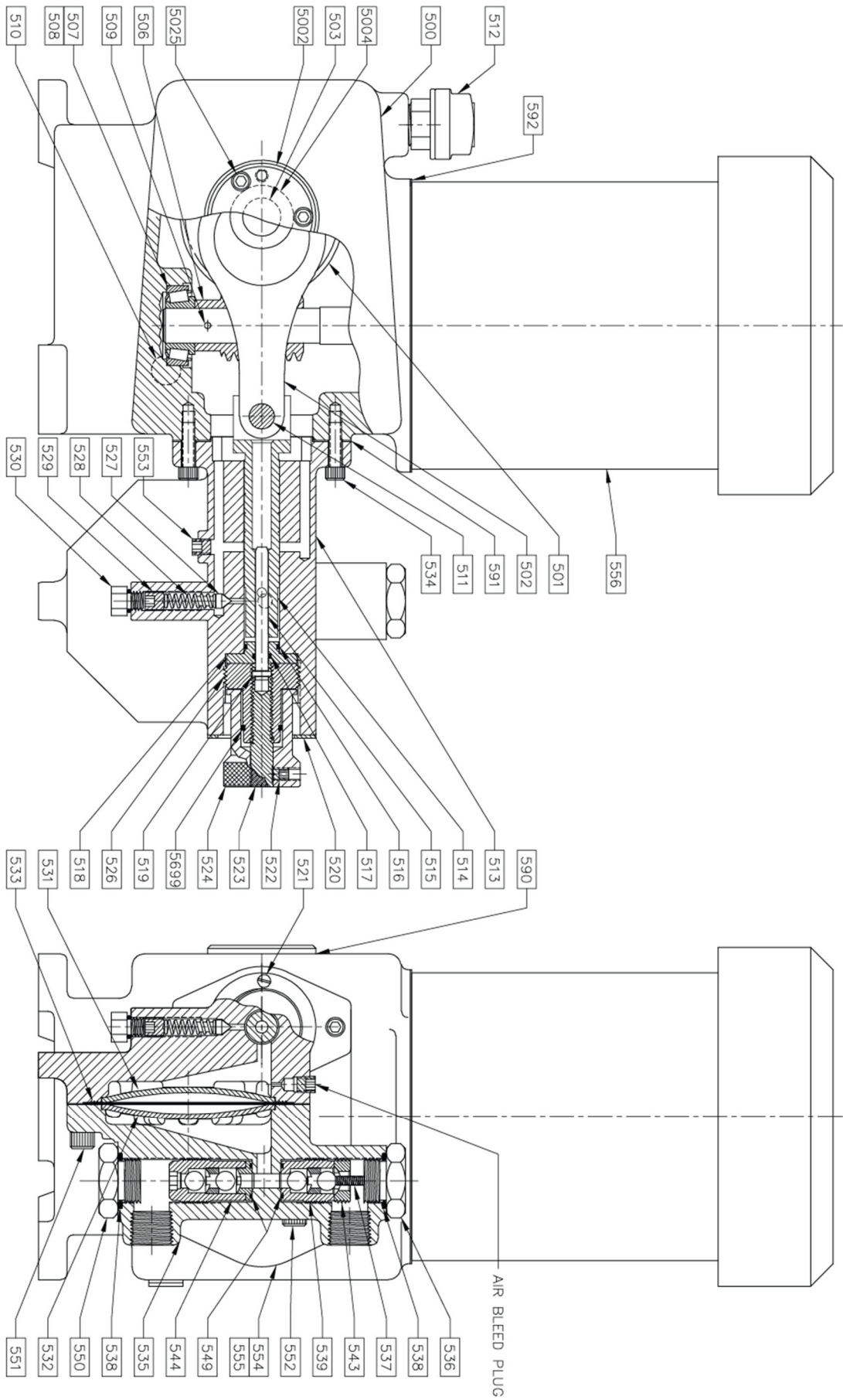

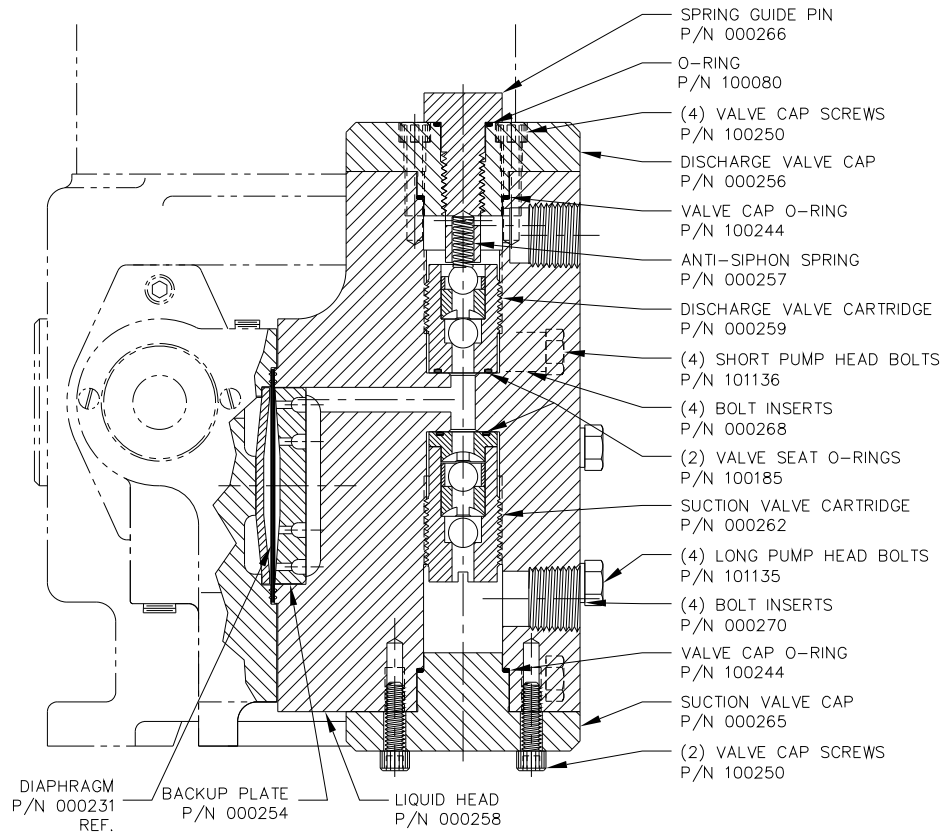

**SERIES 500 PVC HEAD ASSEMBLY WITH SMALL CAVITY
(ASSEMBLY P/N 002074)**

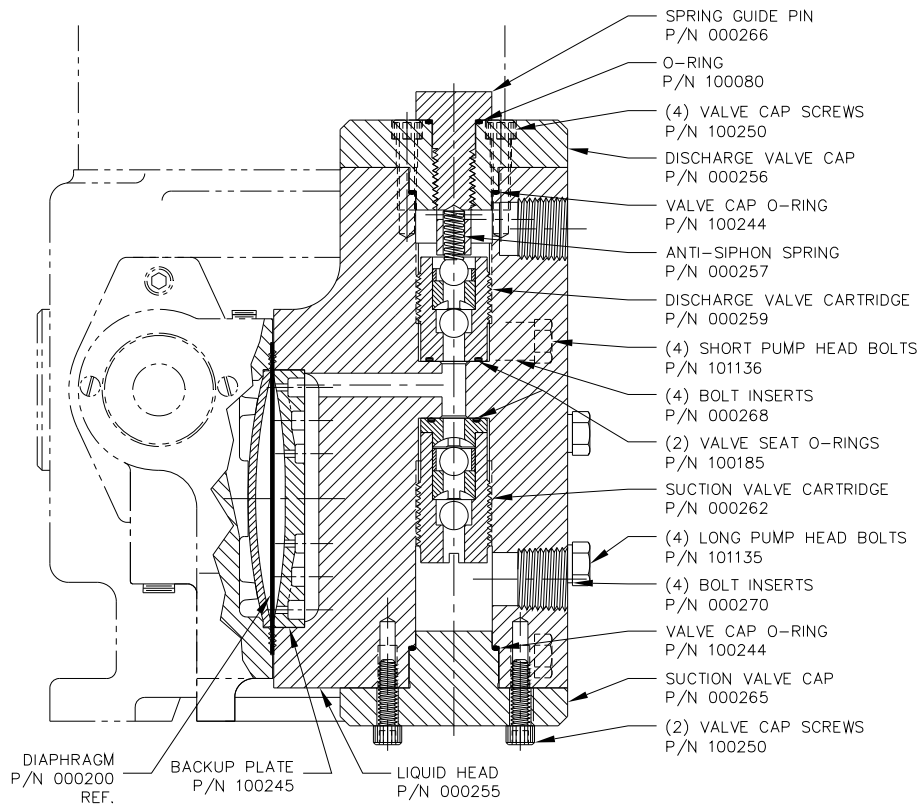

**SERIES 500 PVC HEAD ASSEMBLY WITH STANDARD CAVITY
(ASSEMBLY P/N 002075)**

Kynar liquid end material code [N8] is available in the style used for Series 500-E only. See Page 26.

Drawing LN0005_A

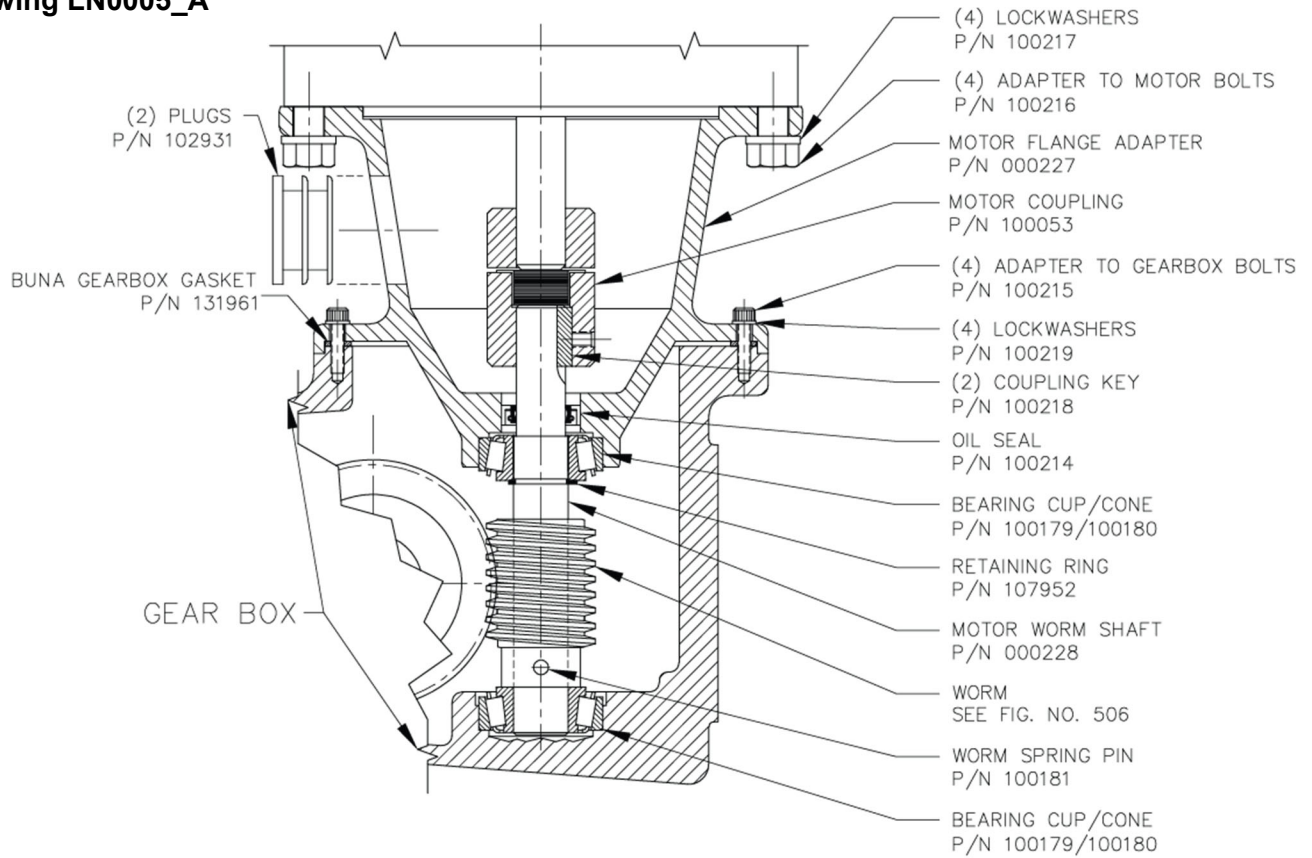

Drawing LN0006_A

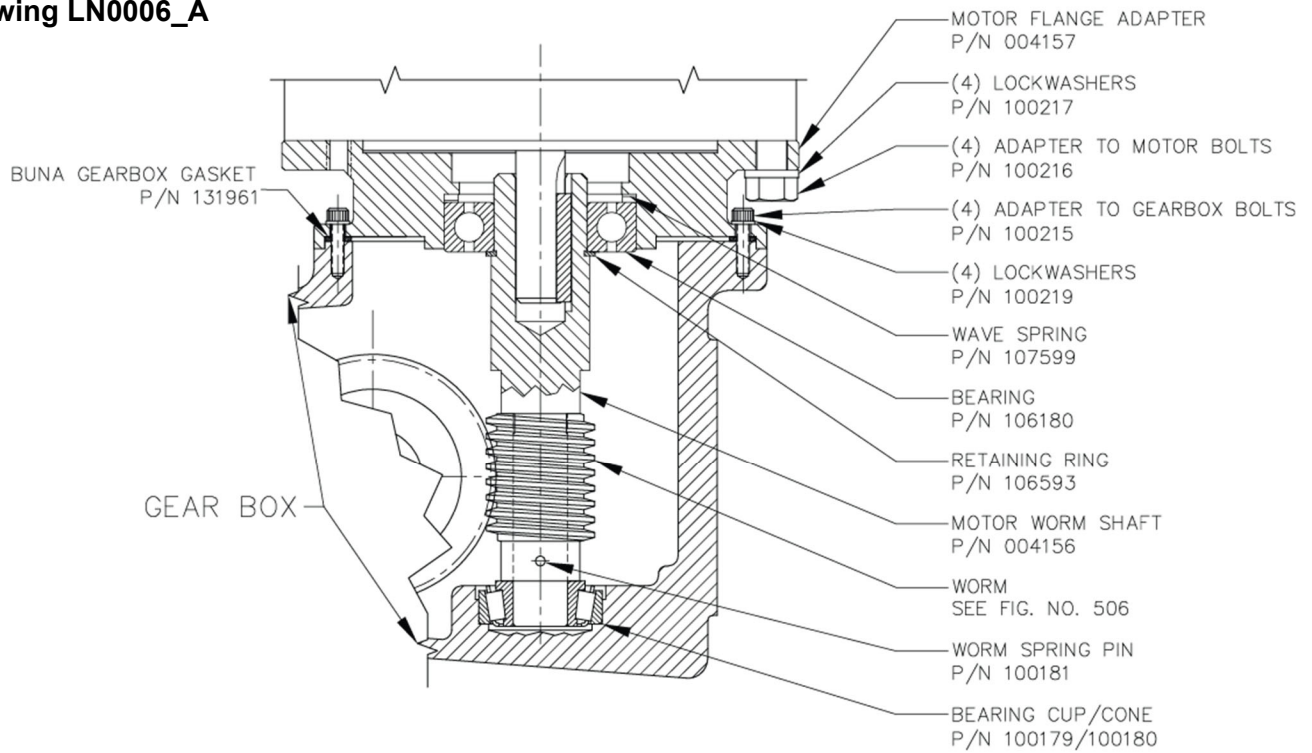

Addendum to Operating and Instruction Manual for the 500 dia-PUMP and 500-A dia-PUMP

This sheet describes the differences in liquid head design of the Series 500-E-AR “dia-PUMP”. This sheet is intended to be used with the Operating and Instruction Manual for Neptune Series 500 and 500-A “Dia-pumps”.

The Series 500-E-AR Pumps are identical to the Series 500-A except for an economy liquid head. All parts of the instruction manual relating to Series 500-A are applicable to 500-E except for liquid head parts and valve instructions. The 500-E-AR consists of: (1) liquid head casting, (1) suction valve (P/N: 004498), (1) discharge valve (P/N: 004503) and (1) air release valve (P/N: 104412).

Installation: Refer to installation instructions of the 500, 500-A and 500 E for proper set up of pump. The unique design of the "AR" liquid head allows you to vent off gases that may accumulate in the pump head from the air release valve (P/N: 104412). You must connect tubing (3/16" ID X 5/16" OD) to the connection on the air release valve and return it back to the supply tank or drain.

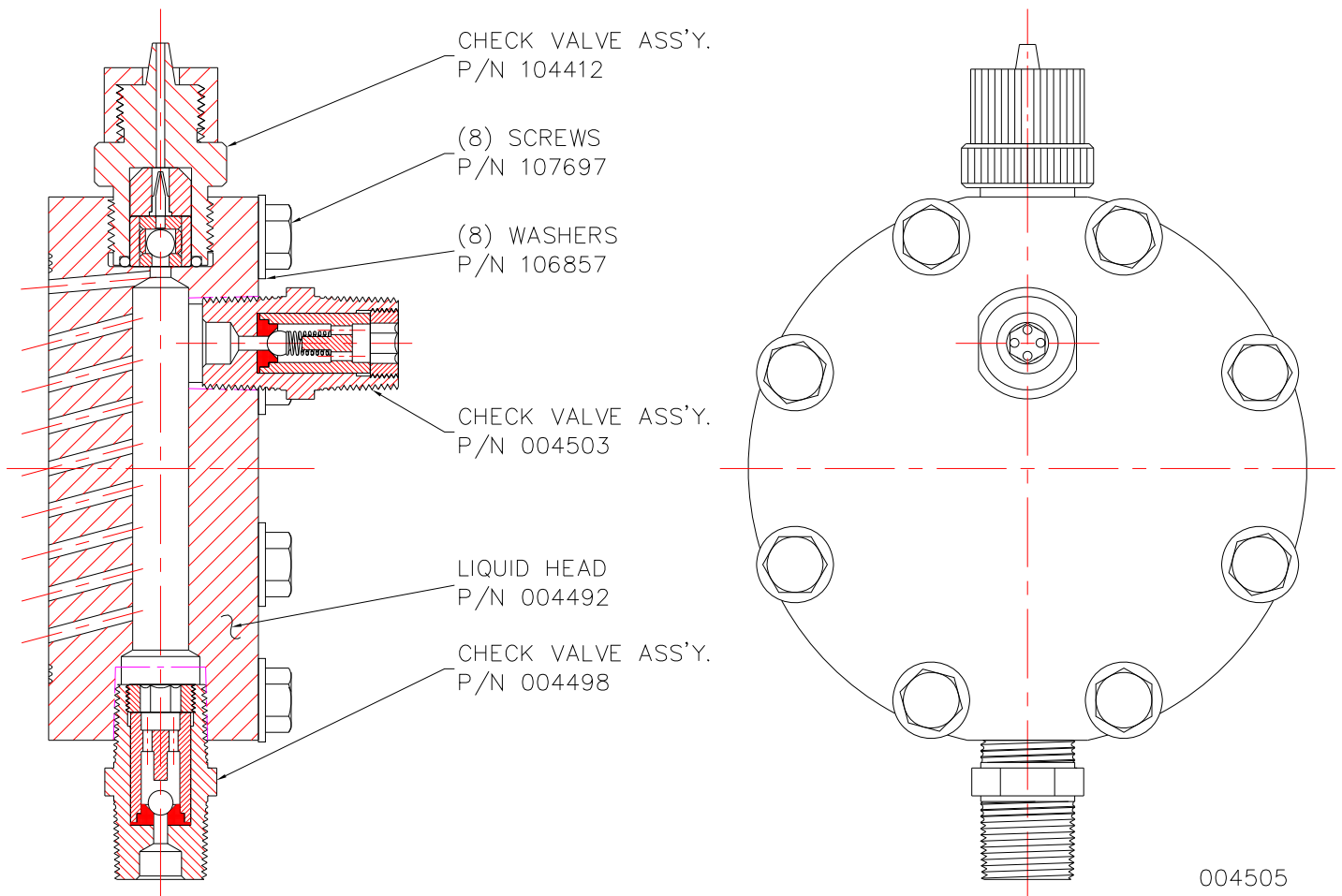

004586---- Complete Spare Parts Kit*

*Includes suction and discharge valve cartridges, diaphragm and all O-rings.

Addendum to Operating and Instruction Manual for the 500 dia-PUMP and 500-A dia-PUMP

This sheet describes the differences in liquid head design of the Series 500-E “dia-PUMP”. This sheet is intended to be used with the Operating and Instruction Manual for Neptune Series 500 and 500-A “dia-PUMP”.

The Series 500-E Pumps are identical to the Series 500-A except for an economy liquid head. All parts of the instruction manual relating to Series 500-A are applicable to 500-E except for liquid head parts and valve instructions. The 500-E liquid head consists of: (1) liquid head casting, (1) back-up plate (on metal head models only), and (2) valve cartridges. The valve cartridges are replaced as a unit; they cannot be disassembled.

The following parts are unique to Series 500-E Models:

DESCRIPTION	QTY.	CODE N3 316SS Part #	CODE N5 PVC Part #	CODE N8 KYNAR Part #
Pump Head	1	003276	003278	003326
Valve Cartridge Suction	1	003321	003279	003332
Back-Up Plate	1	000195	NA	NA
Valve Cartridge Discharge	1	003321	003279	003332
Pump Head 5/16-18 Screws	8	100205	107697	107697
Pump Head 5/16 Washers	8	NA	106857	106857
Complete Spare Parts Kit*	1	003385	003386	003387

*Includes suction and discharge valve cartridges, diaphragm and all O-rings.

NOTE: PRIMING PROCEDURE

Series 500-E pumps have no anti-siphon spring to defeat when priming, they also do not have a valve cap to vent and bleed air. To bleed air on initial start-up it will be necessary to open a valve to the atmosphere in the discharge line before the first isolation valve. If there is no valve in the particular installation, then breaking the piping connection at tubing joint or union will allow the air to escape while the pump is primed. This is only required when first starting a new installation. Since there is no anti-siphon spring, it is necessary to install a backpressure valve in the line when pumping to atmospheric or low-pressure injection points.

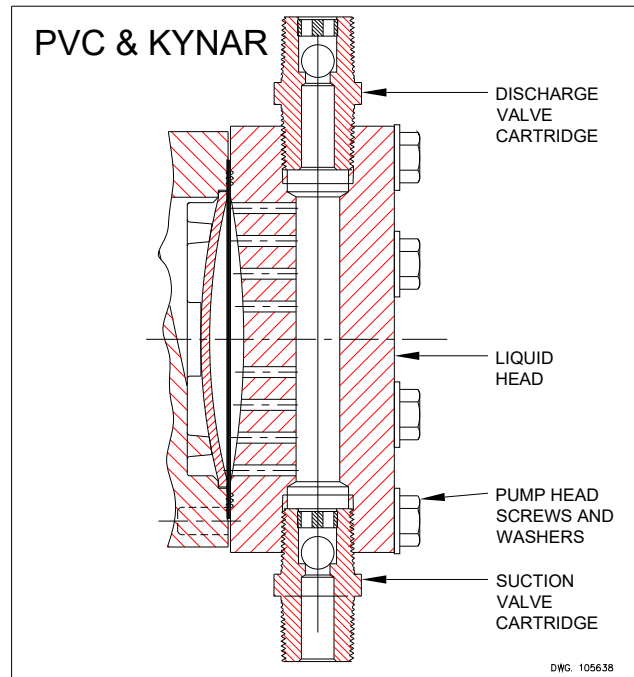
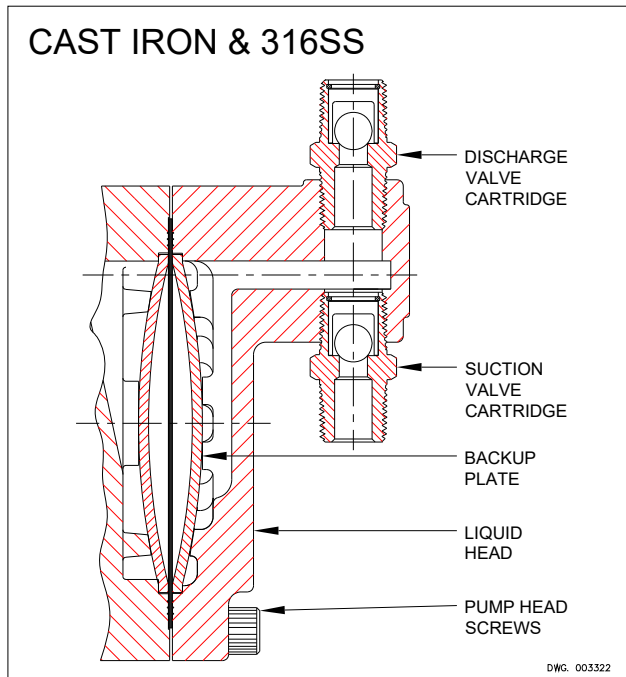

Valve cartridges remove as one piece. Apply pipe dope or Teflon paste to threads to reinstall.

THE FOLLOWING CHANGES IN TEXT MUST BE CONSIDERED WHEN USING THIS MANUAL FOR THE SERIES 500-A “dia-PUMP”. EXCEPT FOR THE DIFFERENCES LISTED BELOW, THIS INSTRUCTION MANUAL APPLIES COMPLETELY TO BOTH THE SERIES 500 AND SERIES 500-A “dia-PUMP”.

PAGE	SECTION	PARAGRAPH	
7	4.0.1	2	Drawing number 5024 illustrates the location of the internal relief valve (FIG. #527 thru #530).
7	4.0.21		Location of 500-A “dia-PUMP” Internal Relief Valve is on top of the Pump Body, not as shown in Figure IV.
13	15.0.3		Remove retaining bolts ... (FIG. #5016, 5018, 5019, 5020)
13	15.0.4		Turn Case (FIG. #5016, 5018, 5019, 5020)
13	15.0.5		To replace motor ... (FIG. #5016, 5018, 5019, 5020)

Parts for Series 500-A “dia-PUMP” not common to Series 500 “dia-PUMP”. Refer to Drawing 5024

FIG. NO.	DESCRIPTION	QTY.	PART NUMBER
5002	Shaft Retainer Assembly	1	000242
5003	Gear Shaft	1	100251
5005	Worm Gear 37 SPM	1	000292
5006	Worm Gear 72 SPM	1	000293
5007	Worm Gear 117 SPM	1	000291
5008	Worm Gear 175 SPM	1	000294
5016	Gear Box (Model 500 Only)	1	000288
5018	Gear Box (Model 510/515 Only)	1	000282
5019	Gear Box (Model 520/522/525 Only)	1	000283
5020	Gear Box (Model 530/532/535/538 Only)	1	000284

RECOMMENDED SPARE PARTS

The Spare Parts Kits listed on page 20 of this manual comprise the recommended spare parts for all Series 500 dia-PUMPS.

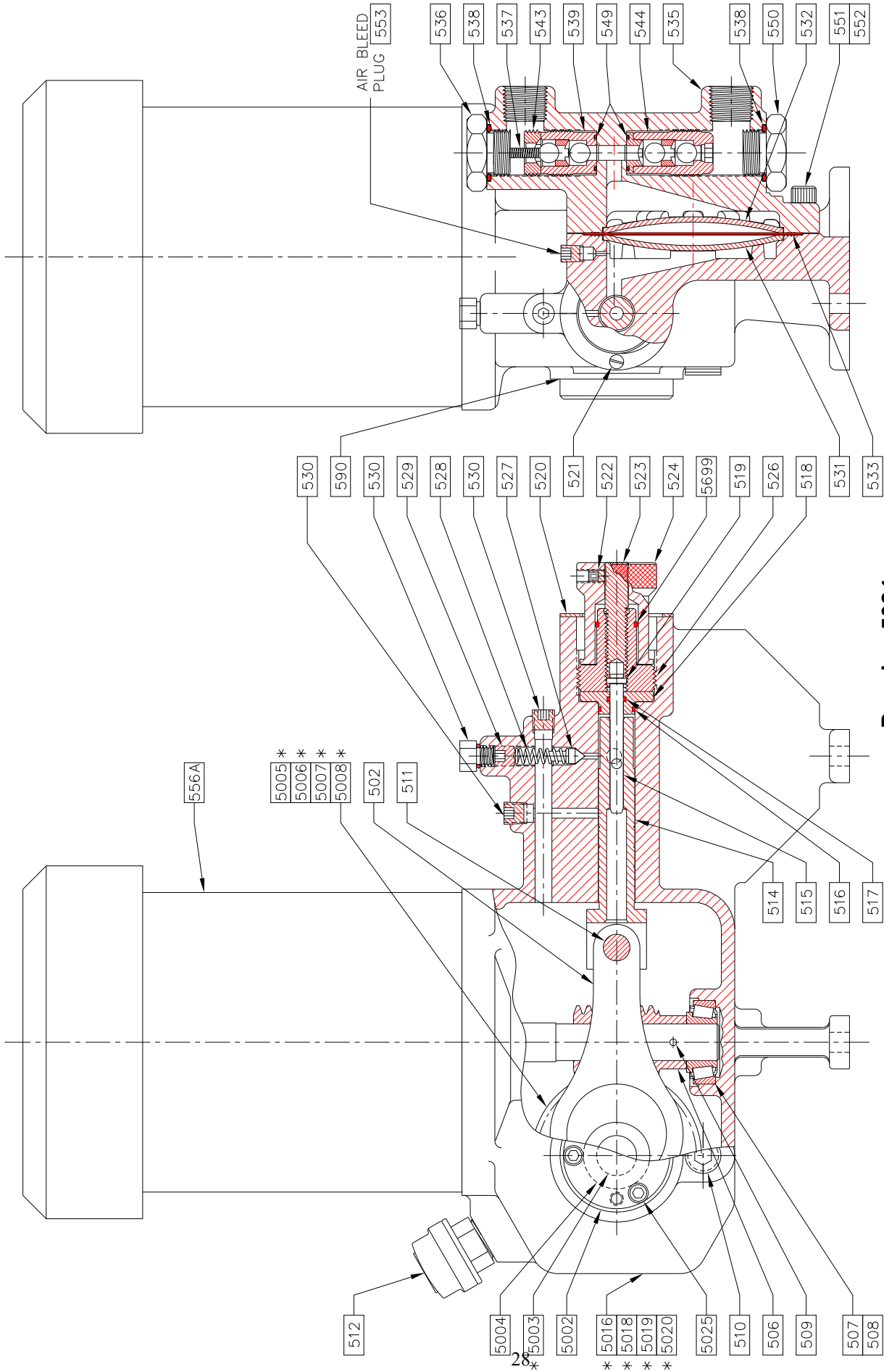

Drawing 5024

INTRODUCTION

The Neptune Series 500 “dia-PUMP” is available with a special liquid end to handle higher viscosity liquids. Model numbers of pumps are for example 515-VS-N3 or 535-VS-N3.

This liquid end, which is only available in 316SS, is different than the standard liquid end as the suction valve, back up plate, and liquid head are modified to allow oversized porting to enable thick liquids to be drawn into the pump on the suction stroke. All other parts of the pump are identical to the standard pump.

Note, the suction connection is directly up from below and the normal suction connection is plugged. The pump must be elevated as the inlet connection is plugged. The pump must be elevated as the inlet connection extends below the plane of the gear box seat.

Maintenance instructions are identical to the standard pump. The four parts which are different from the standard unit are shown below.

RECOMMENDED SPARE PARTS

FIG. NO.	DESCRIPTION	QTY.	PART NUMBER
533	Diaphragm	1	000200
539	Discharge Valve Assembly	1	000209
	Check Valve Assembly	1	003117
538	Valve Cap O-Ring	2	100200
516	Sealing Plate O-Ring (Model 515)	2	100184
516	Sealing Plate O-Ring (Models 520, 522, 525)	2	100185
516	Sealing Plate O-Ring (Models 530, 532, 535, 537)	2	100186
516	Sealing Plate O-Ring (Model 547)	2	100244
549	Valve Seat O-Ring	2	100204

003139-----Complete Spare Parts Kit, Includes Diaphragm and all O-Rings.

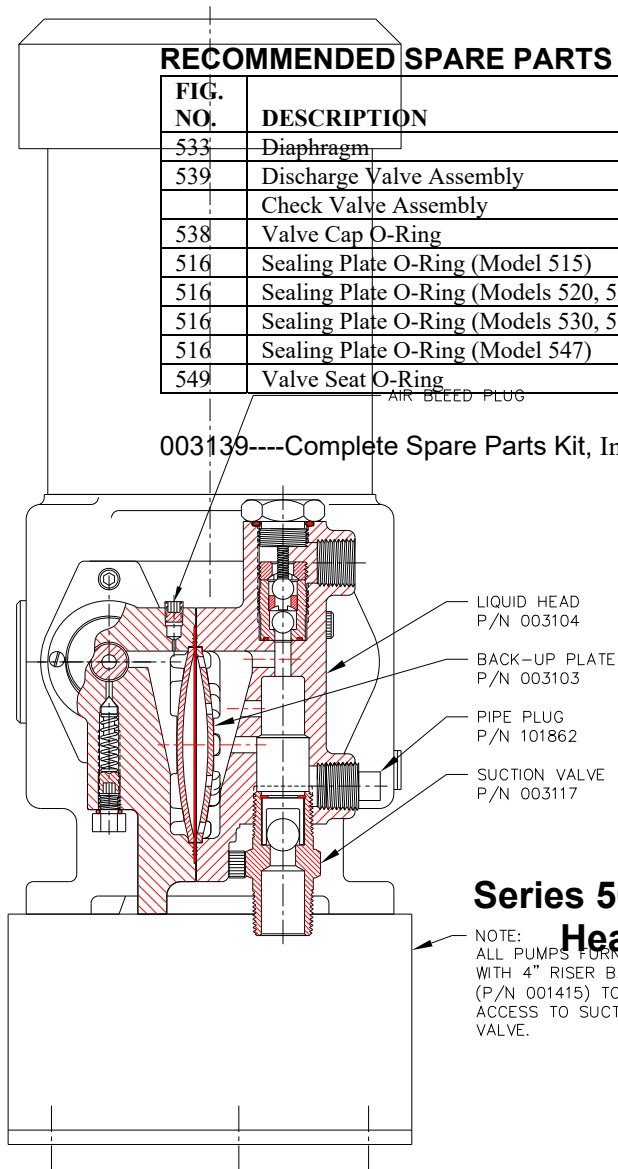

**Series 500VS (High Viscosity)
Head Parts Drawing
C-003105**

NOTE:
ALL PUMPS FURNISHED
WITH 4" RISER BASE
(P/N 001415) TO INSURE
ACCESS TO SUCTION
VALVE.

INTRODUCTION

A special version of the Neptune Series 500 Pump is the Model 5003 and 5005. This pump is different than the standard pump due to the unique Low-Flow design and uses a Metering Device with extremely close tolerances. (Correct installation is critical for proper pump operation). Refer to Parts Drawing S00126 for cross-sectional details. This drawing also indicates each part of the Model 5003 and 5005 that is not common to the other pumps within the Series 500.

Generally, the maintenance and repair procedures for the Model 5003 and 5005 are the same as those shown in the Operating and Instruction Manual for the Series 500 and 500-A Pumps. Failure to follow these instructions could cause pump output to become erratic, or stop altogether.

PUMP CALIBRATION

Each pump is tested at the factory prior to shipment to assure proper operation without leakage at the maximum capacity and discharge pressure specified, with a constant flooded suction of 2 feet of water. For precise capacity control in the field, a calibration test under actual operating conditions with the actual piping arrangements is frequently desirable. Use a calibration drawdown cylinder in the suction line.

After the suction and discharge lines are piped with a convenient sampling point in the suction line, and the pump has been suitably primed, test samples are collected at 25%, 50% 75% and 100% capacity settings. A straight line results when these points are plotted on graph paper. This graph can be used as a calibration curve for an intermediate setting as long as suction and discharge conditions remain constant.

It is important to realize that the sample at 50% will not necessarily be 1/2 that of 100%, nor will any other sample points be to a specific percentage of the 100% value, but the pump will give repetitive samples at the same setting. This is due to the extremely low volume of the pump which results in a shifting zero flow point as pressure increases and can be seen in the curve below.

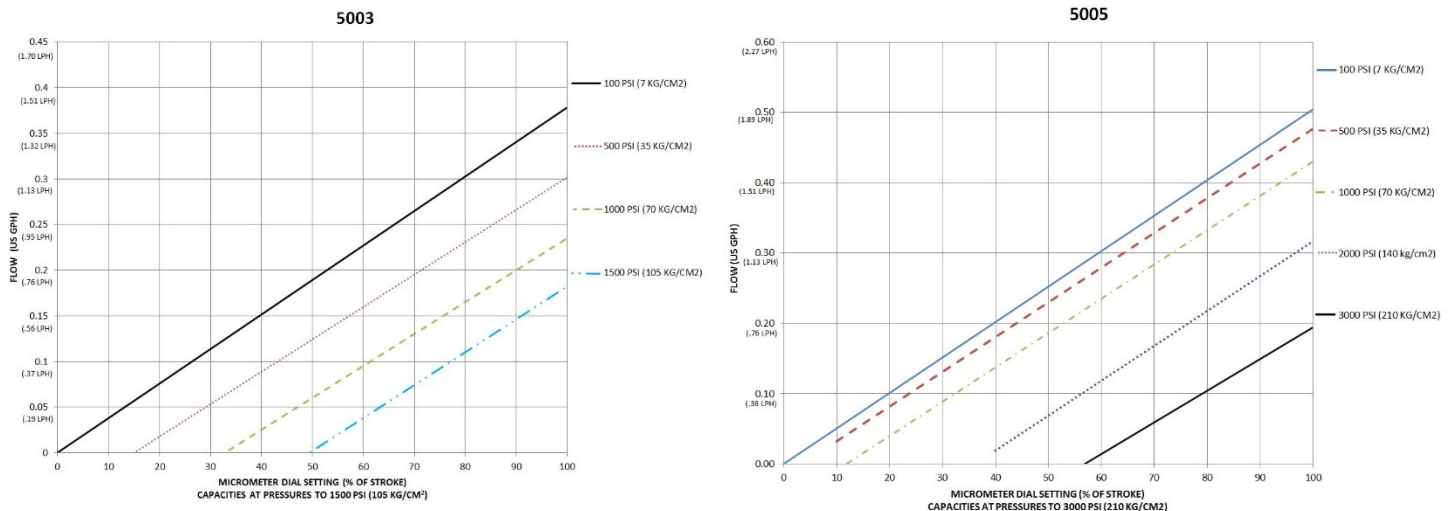

THIS MODEL MUST BE INSTALLED WITH FLOODED SUCTION.

The hydraulic fluid for “5003” and “5005” Pump supplied by Neptune is Mobil Synthetic Oil 0W30. Common sources for hydraulic fluid are listed on page 5.

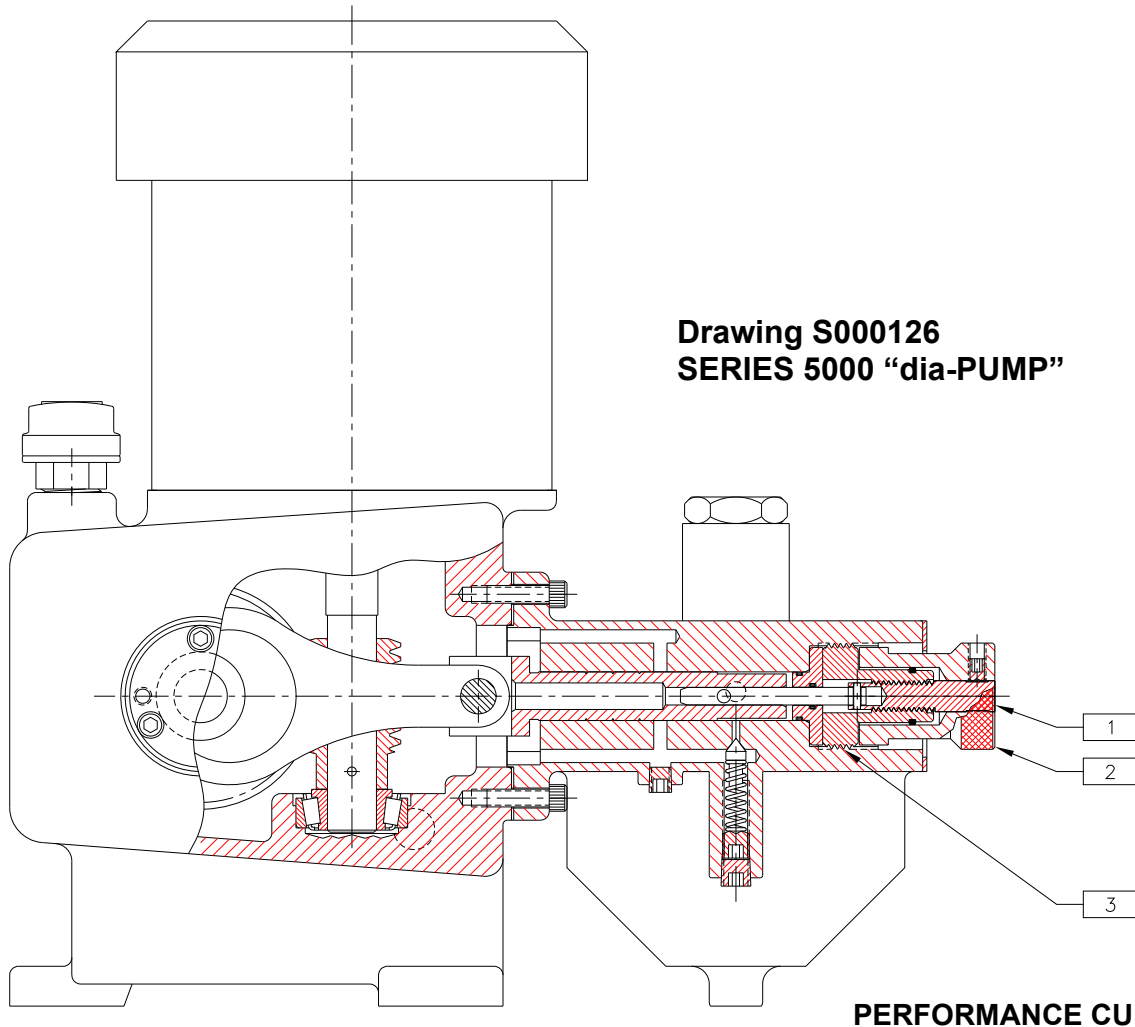

**Parts for Series 5000 "dia-PUMP" not common to Series 500 "dia-PUMP".
Refer to Drawing S00126**

FIG. NO.	DESCRIPTION	QTY.	PART NUMBER
1	Control Rod Positioner for 5003	1	004839
	Control Rod Positioner for 5005	1	004834
2	Control Knob Assembly for 5003	1	004845
	Control Knob Assembly for 5005	1	004844
3	Sealing Nut for 5003	1	004840
	Sealing Nut for 5005	1	004835

RECOMMENDED SPARE PARTS – same as 500 Series, see page 20

PARTS ORDERING INSTRUCTIONS

Note: For prompt entry of parts orders; your order must include model number and serial number.

THEORY OF OPERATION

The instructions below are for Neptune’s optional Double Diaphragm Kit which is available for the Neptune Series 500 and 500-A “dia-PUMPs”.

Use of a double diaphragm allows diaphragm to be monitored and provides an early warning upon failure of either diaphragm allowing repairs to be made before process fluid mix with the pump hydraulic fluid.

Neptune’s double diaphragm is a kit which may be retrofitted to any pump currently in service or may be installed on a new pump at the factory.

Figure 1 illustrates a Double Diaphragm Assembly. An intermediate plate is located between the oil and liquid heads with one diaphragm on each side of the intermediate plate. The Intermediate Plate is connected to a rupture alarm or pressure switch via a capillary system. The area between the diaphragms is evacuated. Rupture in either diaphragm produces an increase in volume and, therefore, a pressure increase, which can be sensed by a pressure switch for alarm purposes.

DISASSEMBLY OF INTERMEDIATE PLATE

- 1.0.0 Shut pump off and disconnect suction and discharge piping. Remove drain plug and drain hydraulic fluid from the gearbox.
- 1.0.1 Remove 8 Screws and remove the liquid head assembly. Some hydraulic oil and process fluid will spill out when the head is removed.
- 1.0.2 The intermediate plate, which is between the pump heads can be removed easily.
- 1.0.3 Remove the rupture alarm (pressure switch) and clean the capillary system.
- 1.0.4 Replace one or both diaphragms if needed.
- 1.0.5 To reassemble reverse above procedure. Be careful.

FIGURE 1

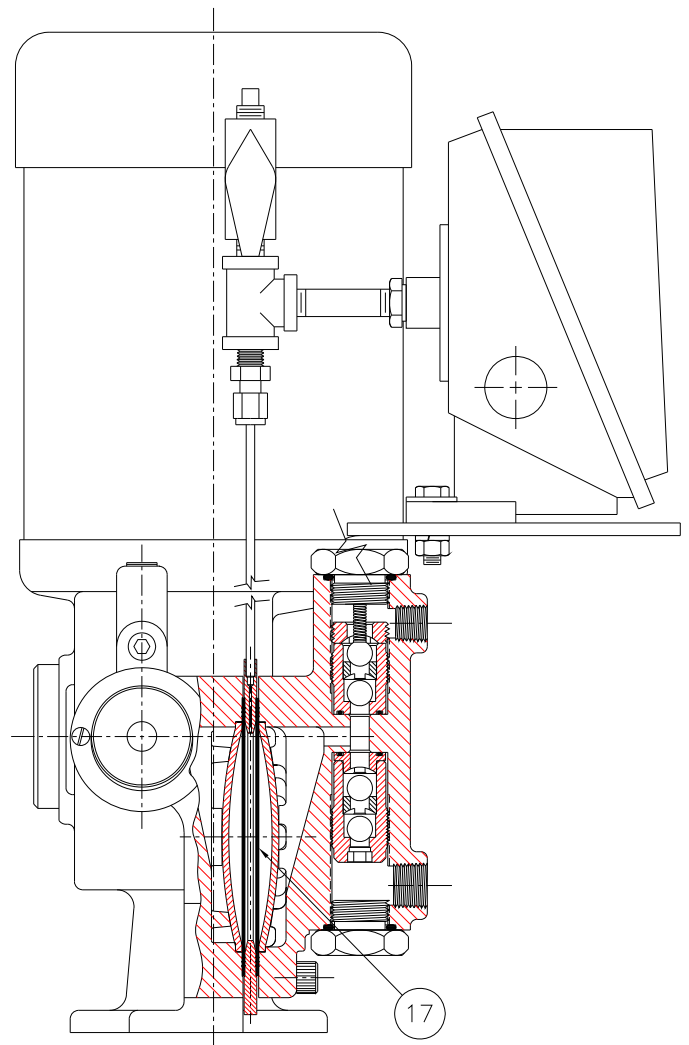

VACUUM AIR FROM INTERMEDIATE SPACE

- 1.0.6 Open valve Item No. 5 (**Figure 2**).
- 1.0.7 To remove air, attach the vacuum pump with a hose connection Item No. 6 to the valve Item No. 5 (**Figure 2**) and pump **until resistance is felt**, for normal operating conditions.

APPENDIX

DOUBLE DIAPHRAGM OPTION

ADDENDUM: Special instructions for Series 500, 500-A & 560 “dia-PUMPS” with Double Diaphragm

- 1.0.8 Close valve Item No. 5
- 1.0.9 Remove the vacuum pump. Plug valve Item No. 5 with a 316SS pipe plug Item No. 12
- 1.0.10 Reinstall the Pump
- 1.0.11 Follow procedure in Neptune Standard Operating and Instruction Manual for Initial Pump Startup

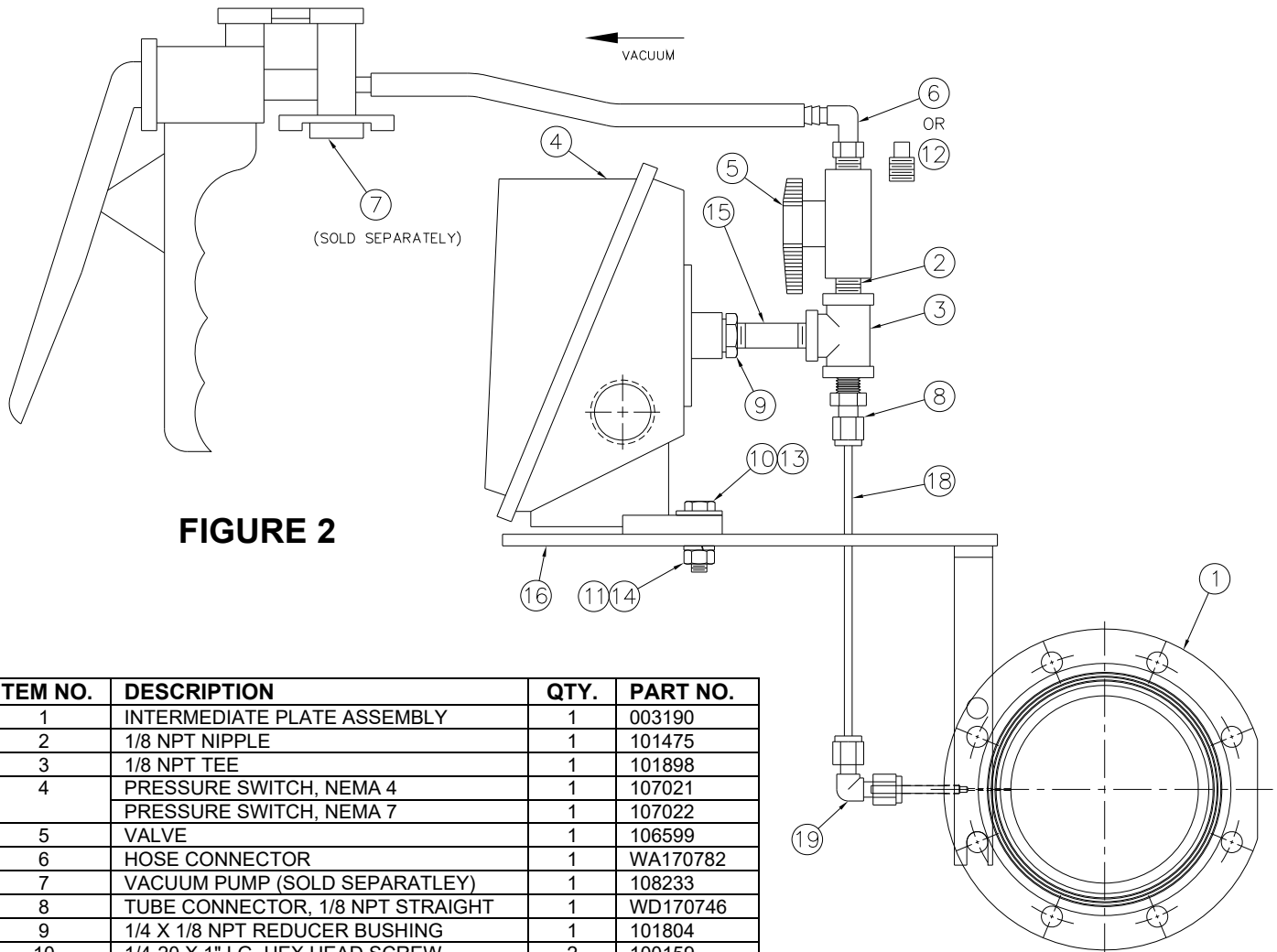

FIGURE 2

ITEM NO.	DESCRIPTION	QTY.	PART NO.
1	INTERMEDIATE PLATE ASSEMBLY	1	003190
2	1/8 NPT NIPPLE	1	101475
3	1/8 NPT TEE	1	101898
4	PRESSURE SWITCH, NEMA 4	1	107021
	PRESSURE SWITCH, NEMA 7	1	107022
5	VALVE	1	106599
6	HOSE CONNECTOR	1	WA170782
7	VACUUM PUMP (SOLD SEPARATELY)	1	108233
8	TUBE CONNECTOR, 1/8 NPT STRAIGHT	1	WD170746
9	1/4 X 1/8 NPT REDUCER BUSHING	1	101804
10	1/4-20 X 1" LG. HEX HEAD SCREW	2	100159
11	1/4-20 HEX NUT	2	100448
12	1/8 NPT PIPE PLUG, 316SS	1	101859
13	1/4" FLAT WASHER	2	108426
14	1/4" LOCK WASHER	2	100169
15	1/8 NPT NIPPLE (FOR METAL HEADS)	1	101477
	1/8 NPT NIPPLE (FOR PLASTIC HEADS)	1	101479
16	BRACKET ASSEMBLY	1	003577
	BRACKET ASSEMBLY (FOR DUPLEX)	1	003600
17	DIAPHRAGM	1	000200
18	VACUUM TUBE	1	004433
19	TUBE CONNECTOR, 1/8 NPT ELBOW	1	104614

NOTE: Neptune furnishes a Mityvac[®] vacuum pump from Mityvac[®] No. 6810 automotive test kit available at many automotive parts stores. (Unit furnished by Neptune is less gauge and automotive adapters)



EC Declarations for Diaphragm Metering Pumps

Manufacturer:

PSG California

22069 Van Buren Street

Grand Terrace, CA 92313 USA

Director of Engineering: Chris Distaso

Signature:

Representative authorized to compile technical files in the European Community:

ALMATEC Maschinenbau GmbH

Carl-Friedrich-Gauß-Straße 5

D - 47475 Kamp-Lintfort Germany

General Manager: Rainer Wulf

Signature:

Product: Neptune Diaphragm Metering Pump Models Series 400, 500, 600, 6000, 7000
Date: 05/22/2019
Serial Number: As Applicable

DECLARATION OF INCORPORATION (Valid for pumps supplied without a motor)

Neptune declares that the products listed above comply with the essential health and safety requirements relevant to the specific product as follows: All Neptune products listed above conform to the Machinery Directive 2006/42/EC: Part 1 of Annex I and comply with the relevant requirements of EN ISO 12100 Safety of Machinery - General Principles for Design - Risk Assessment and Risk Reduction, and DIN EN 809 Pumps and Pump Units for Liquids - Common Safety Requirements.

This subassembly is incomplete and must not be put into service until the machinery into which it is to be incorporated has been declared in conformity with the provisions of Directive 2006/42/EC ("The Machinery Directive") and any other applicable Directives.

DECLARATION OF CONFORMITY (Valid for pumps supplied with a motor)

Neptune declares that the products listed above comply with the essential health and safety requirements relevant to the specific product as follows: All Neptune products listed above conform to the Machinery Directive 2006/42/EC: Part 1 of Annex I and comply with the relevant requirements of EN ISO 12100 Safety of Machinery - General Principles for Design - Risk Assessment and Risk Reduction, DIN EN 809 Pumps and Pump Units for Liquids - Common Safety Requirements, and DIN EN ISO 4871 - Declaration and Verification of Noise Emission Values of Machinery and Equipment. The supplied motor conforms to the 2014/35/EU - The Low Voltage Directive (compliance exists from the motor manufacturer).

This product **may not be used** in an explosive environment.

Revised 2-13-2013
Rev 5, Revised 6-16-2014
Rev 6, Revised 5/18/2015
Rev 7, Revised 03/15/2018
Rev 8, Revised 05/22/2024