



INSTALLATION OPERATION & MAINTENANCE



NEPTUNE

Series 6000 “dia-PUMPS”

Models 6100 thru 6250



NEP-ZL107602

PSG
22069 Van Buren Street
Grand Terrace, CA 92313 USA
P: +1 (215) 699-8700 F: +1 (215) 699-0370
neptune1.com

Copyright 2018 PSG®, a Dover Company

NEP-ZL107602
02.2022_REV 9



WARNING

LOCKOUTS ARE REQUIRED BEFORE
SERVICING THIS EQUIPMENT.

SAFETY INSTRUCTIONS:

Shut off/Lockout pump Power before Servicing.

Be certain pump isolation valves are
Closed and chemical is shut off.

Bleed pressure before servicing.

In case of emergency, shut pump down completely
by disconnecting motor power supply.

To prevent unexpected start-up, disconnect motor
from power supply when power outage happens.

WARNING

Please read thoroughly before installation, operation or maintenance of any Neptune pump

EQUIPMENT MISUSE HAZARD

Equipment misuse can cause the equipment to rupture, malfunction and result in serious injury.

- This equipment is for professional use only.
- Read all instruction manuals, tags, and labels before operating the equipment.
- Use the equipment only for its intended use.
- Do not alter or modify this equipment.
- Be certain all operators of this equipment have been trained for safe working practices, understand its limitations, and wear safety goggles and or equipment when required.
- Do not exceed the maximum working pressure of the system as mentioned on the pump tag.
- Do not use the pump head or the suction or discharge piping to pull the equipment.
- Do not move pressurized pump.
- Use fluids or cleaning agents for cleaning that are compatible with the pump parts. Read the fluid and cleaning agent manufactures warnings and also refer to the material compatibility chart
- Comply with all applicable local, state and national safety regulations.
- Do not allow pump to run dry for a long periods of time.

PRESSURIZED EQUIPMENT HAZARD

Spray from leaks or ruptured components can splash fluid in the eyes or on the skin and cause serious injury.

- Shut off the pump and depressurize before performing any maintenance.
- Do not tamper with or perform unspecified alteration of this device.
- Operate only at rated pressure. Excessive pressure during normal operation can cause leakage and rupture to the pump head joint and/or pipes. Rated pressure can be found on pump name tag.
- Use only pipe, hose, and hose fittings rated for maximum rated pressure of the pump or the pressure at which the pressure relief valve is set at.
- Always wear protective clothing, face shield, safety glasses and gloves when working on or near your metering pump.
- Additional precautions should be taken depending on the solution being pumped. Refer to MSDS precautions from your solution supplier.
- Do not stop or deflect fluid leaks with your hand, body, glove, or rag.
- Tighten all fluid connections before operating the equipment.
- Replace worn, damaged, or loose parts immediately.
- Before performing any maintenance requiring pump head and or valve (wetted parts) disassembly, be sure to relieve pressure from the piping system and where hazardous process chemicals are present.
- Make the pump safe to handle for the personal and the environment by cleaning and chemically neutralizing the pump as appropriate.
- Wear protective clothing and use proper tools as appropriate to avoid any injury.
- If the diaphragm has failed, process chemical may have contaminated the pump hydraulic oil. Handle with appropriate care. Clean the pump and replace oil as necessary. Discard the contaminated oil as per the local code.
- If the diaphragm fails in a double diaphragm pump, pressurized process chemical can be present in the Neptune leak detection vacuum system. Take proper care to clean and handle them.

FIRE AND EXPLOSION HAZARD

Improper grounding, poor air ventilation, open flames, or sparks can cause a hazardous condition and result in fire or explosion and serious injury.

- Ground the equipment. See motor installation instruction for grounding procedure.
- Do not pump non recommended flammable or explosive fluids.
- Static electricity may generate by fluid moving through pipes and hoses. A static spark could be produced by high fluid flow rate. Earthing of the pump is a must.
- Provide fresh air ventilation to avoid the possible buildup of flammable fumes from the process chemicals.
- Keep the pump area free of debris, including cleaning agent, rags, and any flammable material.
- Follow the cleaning agent and other cleaning recommendations as mentioned in the operation and instruction manuals.
- Use cleaning agent with the highest possible flash point to clean the pump parts if needed.
- If there is any static sparking while using the equipment, stop operation at once. Identify and correct the problem before starting up the pump.

TOXIC FLUID HAZARD

Hazardous fluids or toxic fumes can cause serious injury or death if splashed in eyes or on the skin, swallowed, or inhaled.

- Know the specific hazards of the fluid you are using. Read the fluid manufactures warnings.
- Consider chemical compatibility when selecting pump material. Reference Neptune chemical resistance guide in: <https://www.psgdover.com/neptune/download-library/guides> or contact Neptune Sales for recommendation.
- Store hazardous fluid in an approved container. Dispose of hazardous fluid according to all local, state and national guidelines.
- Wear the appropriate protective clothing, gloves, eyewear and respirator.
- Pipe and dispose of the exhaust air safely. If diaphragm fails, the fluid may be exhausted along with the air in mechanical diaphragm pump. Also oil vapor may breath out of the air breather installed on the gear box.

SOUND HAZARD

The sound pressure level of the pump may exceed 80dBA in some of the pumps.

- Observe all safety precautions when operating the pump within close proximity for extended periods by wearing hearing protectors.
- Extended exposure to elevated sound levels will result in permanent loss of hearing acuteness, tinnitus, tiredness, stress, and other effects such as loss of balance and awareness.

MECHANICAL HAZARD

The pump may shake or vibrate during operation.

TABLE OF CONTENTS

SECTION	PARAGRAPH		PAGES
I		GENERAL DESCRIPTION	5
		LIMITED WARRANTY	6
		PARTS ORDERING INSTRUCTIONS	7
II		INSTALLATION INSTRUCTIONS	
	1	GENERAL	8
	2	SUCTION PIPING	9
	3	DISCHARGE PIPING	10
	4	ADJUSTMENT OF INTERNAL RELIEF VALVE	10
	5	INSTALLATION OUTDOORS	12
	6	STARTUPPROCEDURE	12
III		NORMAL MAINTENANCE	
	7	MAINTENANCE	13
IV	8	MOTOR OPERATING CONDITIONS	15
V		TROUBLE SHOOTING CHART	16
VI		PARTS	
	9	SPAREPARTS	17
		PARTS LISTS	19, 21
VII		ELECTRONIC STROKE CONTROL	
	10	SPECIAL INSTRUCTIONS	22
VIII		DRAWINGS	
		DIRECTION OF MOTOR ROTATION	9
		INTERNAL RELIEF VALVE SETTINGS	10
		LIQUID HEAD ASSEMBLY	12
		PARTS DRAWINGS	18, 20
		ELECTRONIC STROKE CONTROL	22
IX		DOUBLE DIAPHRAGM OPTION	
	11	INSTALLATION AND OPERATION	25
X		MAINTENANCE LOG	

SECTION I GENERAL DESCRIPTION

The Neptune Series 6000 “dia-PUMP” is a reliable metering pump of the high-pressure diaphragm type. Under constant conditions of temperature, pressure, and capacity adjustment settings, a +/- 1% metered discharge volume is maintained.

A plunger reciprocating at a fixed stroke displaces hydraulic fluid, which actuates a flexible, chemically inert, Teflon diaphragm to create pumping action. The capacity of the pump is regulated by controlling the volume of hydraulic fluid, which bypasses the diaphragm cavity.

Metering accuracy is maintained by a control rod, which allows hydraulic fluid replacement and air venting automatically with each stroke, while also taking into account temperature changes of the hydraulic fluid. Metering accuracy is also insured by the use of double ball check valves on the suction and discharge of the pump.

PLEASE READ THE INSTRUCTION MANUAL COMPLETELY BEFORE INSTALLING THE PUMP



SECTION I

NEPTUNE CHEMICAL PUMP COMPANY LIMITED WARRANTY

All Neptune Pumps are tested at the factory prior to shipment. Each part used in their construction has been carefully checked for workmanship.

If the pump is installed properly, Neptune Chemical Pump Company warrants to the purchaser of this product for a period of twelve months from the date of first use or eighteen months from shipment, whichever occurs first, this product shall be free of defects in material and/or workmanship, as follows:

1. Neptune Chemical Pump Company will replace, at no charge, any part that fails due to a defect in material and/or workmanship during the warranty period, FOB our factory, North Wales, Pennsylvania. To obtain warranty service, you must forward the defective parts to the factory for examination, freight pre-paid.¹
2. This warranty period does not cover any product or product part, which has been subject to accident, misuse, abuse or negligence. Neptune Chemical Pump Company shall only be liable under this warranty if the product is used in the manner intended by the manufacturer as specified in the written instructions furnished with this product.

Any express warranty not provided in this warranty document, and any remedy for breach of contract that, but for this provision, might arise by implication or operation of law, is hereby excluded and disclaimed. Under no circumstances shall Neptune Chemical Pump Company, Inc. be liable to purchaser or any other person for any charge for labor, repairs, or parts, performed or furnished by others, nor for any incidental consequential damages, whether arising out of breach of warranty, express or implied, a breach of contract or otherwise. Except to the extent prohibited by applicable law, any implied warranty of merchantability and fitness for a particular purpose are expressly limited in duration to the duration of this limited warranty.

Some states do not allow the exclusion or limitation of incidental or consequential damages, or allow limitations on how long any implied warranty lasts, so the above limitations may not apply to you. This warranty gives you specific legal rights, and you may have other rights, which may vary from state to state.

IMPORTANT

SHOULD IT BE NECESSARY TO SEND THE PUMP TO THE FACTORY FOR REPAIR OR MAINTENANCE REBUILDING; DRAIN ALL OIL AND CHEMICAL FROM PUMP BEFORE SHIPPING. FAILURE TO DO SO CAN CAUSE EXTENSIVE DAMAGE TO THE MOTOR.

¹SEE IMPORTANT NOTICE -RETURN GOODS AUTHORIZATION

IMPORTANT NOTICE RETURN GOODS AUTHORIZATION

- (1) All equipment returned to Neptune Chemical Pump Company requires proper Returned Goods Authorization Number (RGA) and tags.
- (2) All equipment returned to the factory for repair or service must first be thoroughly flushed and have all chemical contact areas neutralized.
- (3) All equipment which has been in contact with chemicals must be accompanied by a copy of the Chemical Product Material Safety Data Sheet (MSDS).
- (4) Failure to comply with the above instructions will result in equipment being returned to sender, freight collect, without service.

SECTION I

PARTS ORDERING INSTRUCTIONS

The complete model number and serial number of the pump must be furnished to insure prompt and accurate parts service. These numbers are found on the name plate (sample below) located on the side of the pump. Refer to **Section VI** for complete parts lists.

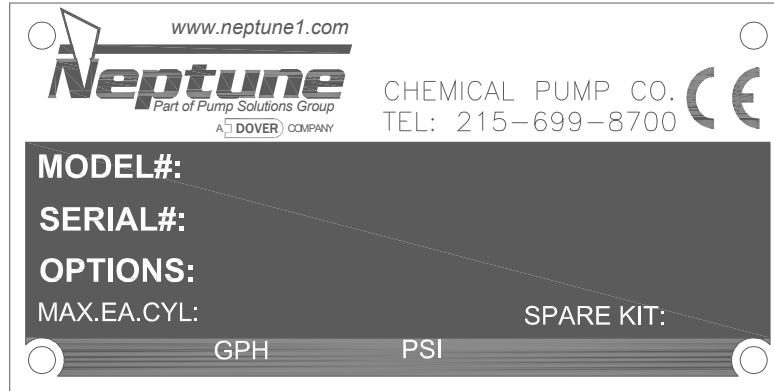

Send all orders or inquiries for parts to:

Email: order.neptune@psgdover.com

Website: www.psgdover.com/neptune.com

NOTE: PLEASE SUPPLY BOTH MODEL AND SERIAL NUMBERS.

SECTION II

INSTALLATION INSTRUCTIONS

Important

- On single phase integral motors, the rotation is set at the factory and must not be changed.
- On three phase integral motors, rotation is determined by noting the fan rotation.
- Pump body should be earth grounded. Ground connection MUST penetrate to bare metal.
- Ground to be clearly marked.
- Check external pressure relief valve setting.
- On some flange mounted motors, the motor rotation may be viewed by removing the cap on the side of the flange. There is no viewing port or coupling access on the close coupled flange mount motors. Rotation is checked by removing the oil fill plug and observing the gear. Correct rotation is indicated by the gear teeth moving downward away from the oil fill hole.
- Please note Figure 1, indicating the correct rotation. (An arrow on the gear box also indicates proper rotation.) Operation with the incorrect rotation will damage the pump and motor.

1.0 GENERAL (REFER TO PART DRAWINGS ON PAGES #18 & #20)

1.0.1 UNPACKING & INSPECTION

When unpacking a pump or chemical feed system, be certain that no parts are thrown away. Examine the equipment for possible damage. If damage has occurred, file claim with the common carrier within 24 hours. Neptune will assist in estimating the repair costs.

1.0.2 The "dia-Pump" should be located on a level surface. Three mounting holes are provided to anchor the pump securely to the mounting surface. All piping to the pump should be supported to prevent stress on the pump input and output fittings.

1.0.3 Before connecting the pump make sure that all fittings are completely clean by flushing thoroughly. Any foreign matter entering the pump can damage the internal parts and severely limit the life of the pump.

1.0.4 A "Y" STRAINER (AT LEAST ONE PIPE SIZE LARGER THAN SUCTION INLET SIZE OF THE PUMP) MUST BE INSTALLED IN THE SUCTION LINE OF THE PUMP TO INSURE AGAINST FOREIGN MATTER ENTERING THE PUMP

1.0.5 It is recommended that shut-off valves and unions be placed in the suction and discharge lines if possible. Such an arrangement will facilitate servicing the pump.

1.0.6 The electrical supply to the pump must match the motor nameplate characteristics. The motor rotation is counter clockwise when viewed from the top of the motor or looking down on the pump. An arrow mark on the gearbox shows the rotation (See Figure 1)

1.0.7 All fittings and connections must be airtight. Otherwise, pump suction capability will be reduced or lost.

IMPORTANT

On single-phase units, the rotation is set at the factory and must not be changed.

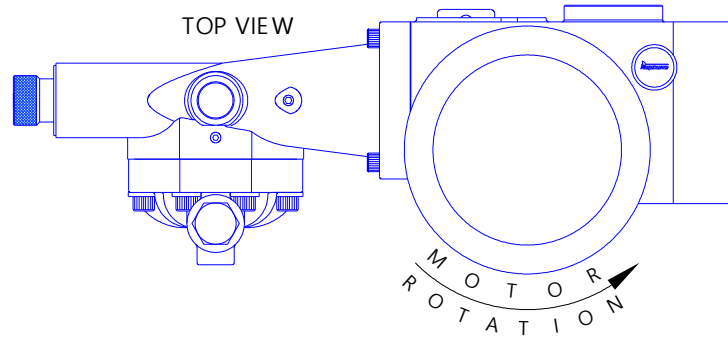

FIGURE 1

Please note Figure 1, indicating the correct rotation. Operation with the incorrect rotation will damage the pump and motor.

- 1.0.7 Please note, that some items in the parts list have more than one part number for an individual figure number. These different part numbers insure unique identification of parts, which are available in more than one material of construction, or as in the case of gears, pistons etc., more than one speed, and sizes. Please use the part number, not the figure number when ordering.
- 1.0.8 Fill gearbox and pump by pouring the hydraulic fluid (drive lubricant) supplied through the fill opening at the rear of the pump. Pour fluid in slowly until it covers the worm gear. The control knob should be in the zero position during the filling.

PLEASE NOTE: TO VENT THE AIR, REMOVE VENT PLUG LOCATED ON TOP OF THE OIL HEAD (#54 on Parts Drawing).

Allow 30 minutes for hydraulic fluid to make its way into pump chamber and then recheck fluid level.

The hydraulic fluid supplied by Neptune is EP SAE 90.

Common sources for hydraulic fluid are:

Shell Oil	Omala S2 G #220
Mobil Oil	Mobil Gear #629
Sun Oil	Sun Oil #220
Texaco	Meropa #220

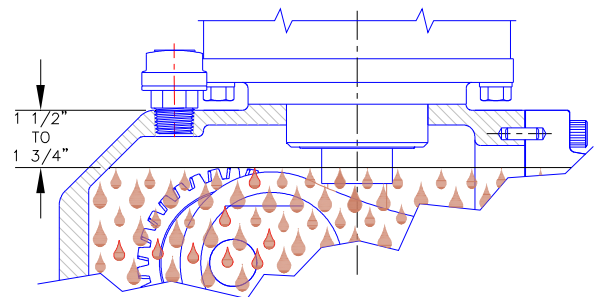

2.0 SUCTION PIPING

- 2.0.1 The suction piping to the pump must be absolutely airtight and one size larger than suction inlet size of the pump. It is suggested that the suction piping be tested with low air pressure and a soap solution to assure that no leaks exist. Limit the total length of the suction line to 3-4 feet for suction lift or 6-7 feet for flooded suction. Minimize bends, elbows, or other restrictions.
- 2.0.2 NEPTUNE RECOMMENDS THAT THE "dia-PUMP" BE OPERATED WITH A FLOODED SUCTION, AS THIS WILL FACILITATE START UP AND INCREASE THE SERVICE LIFE OF THE PUMP.
- 2.0.3 It is highly recommended that all solution tanks be furnished with a low level cut off switch or low-level alarm and cut off switch to prevent the pump from running dry. OPERATION AGAINST A DRY SYSTEM WILL CAUSE DAMAGE TO THE PUMP DIAPHRAGM AND REDUCE THE OPERATING LIFE OF THE PUMP.

3.0 DISCHARGE PIPING

- 3.0.1 It is recommended that the “dia-Pump” operate against a minimum discharge pressure of 50 psig.
- 3.0.2 All Neptune Series 6000 “dia-Pumps” are supplied with an internally pre-set relief valve. This relief valve is set above the actual rated discharge pressure of the pump and is designed to protect the pump should a discharge pressure’ beyond the rated limit of the pump occur.
- 3.0.3 To protect the piping system, it is recommended that an external relief valve as manufactured by Neptune Chemical Pump Company, or equal, be placed in the discharge line of the pump.
- 3.0.4 Discharge piping should equal discharge port size.

4.0 ADJUSTMENT OF INTERNAL RELIEF VALVE

- 4.0.1 All Neptune Series 6000 “dia-Pumps” are supplied with an internally pre-set relief valve. The internal relief valve is set as follows:

APROXIMATE INTERNAL RELIEF VALVE SETTING (PSI)					
Model	1/2 HP	3/4 H/P	1 H/P	1-1/2 HP	2 HP
6100	1200	2000	2500	3500	4000
6150	1000	1500	2000	3000	3500
6250	500	800	1000	1500	2000

- 4.0.2 The internal relief valve is designed to protect the pump itself should a discharge pressure beyond the relief valve setting occur.
- 4.0.3 If a customer order specifies a relief valve setting above those indicated above, the specified setting will be set at the factory. All pumps are tagged with the relief valve setting used by the factory.
- 4.0.4 To protect the external piping system, it is recommended that a relief valve as manufactured by Neptune Chemical or equal be placed in the discharge line of the pump. It is further recommended that this relief valve be piped into return of the tank with clear PVC tubing so that it can be determined if the solution is bypassing through the valve and returning to the tank, indicating a line blockage.
- 4.0.5 Drawings on pages 18 & 20 illustrates the location of the internal relief valve (#32, #33, #34, #35, #36, and #37 on Parts Drawings).
- 4.0.6 The drawing shows a passage connecting the hydraulic fluid reservoir with the hydraulic fluid side of the diaphragm.
- 4.0.7 The passage is interrupted by the relief valve ball (FIG. #37 on Parts Drawing), which is backed up by a relief valve spring (#35 on Parts Drawing).
- 4.0.8 If, during the pump operation, the pressure on the hydraulic fluid side of the pump exceeds the set pressure of the internal relief valve, the ball is forced from its seat allowing the hydraulic fluid to flow back to the reservoir.
- 4.0.9 To reset the relief valve to a higher pressure (the relief valve setting cannot be reduced because of design considerations), instructions are as follows:
- 4.0.10 Connect a test set-up as shown in **Figure 2** (Page 11)

NOTE: All parts must have a working pressure rating above the required set pressure.

4.0.11 Start and run the pump until all air is relieved from the discharge liquid (hand valve open).

4.0.12 Remove relief valve cap (#32 on Parts Drawing).

4.0.13 Close hand valve; pressure gauge should read between 250 and 4500 psi depending on pump model.

4.0.14 Use 5/16" Allen wrench to adjust spring tension by turning relief valve adjusting screw (#34 on Parts Drawing).

(1) To increase pressure, turn relief valve adjusting screw (#34 on Parts Drawing) in.

(2) To decrease pressure, turn relief valve adjusting screw (#34 on Parts Drawing) out.

4.0.15 After resetting or adjusting pressure, replace relief valve cap (#32 on Parts Drawing).

CAUTION

Never turn relief valve adjusting screw (# 34 on Parts Drawing.) completely in.

Do not attempt to set the internal relief valve more than 25% in excess of nameplate rating.

Take out Relief Valve cap to access Relief Valve screw (#32 on Parts Drawing). Insert Hex wrench to adjust relief valve setting.



FIGURE 2

5.0 INSTALLATION OUTDOORS

The “dia-Pump” is a totally enclosed pump, which can be used outdoors or indoors. When installed outdoors, make sure that the pump is protected against extremes of nature as follows:

- 5.0.1 Running of the pump when exposed to tropical sunshine with ambient temperature above 90°F (32°C) would cause excessive oil and motor temperatures. The pump should be shaded and located in such a way as to permit an ample degree of air circulation.
- 5.0.2 Under cold conditions, the pump should be insulated and a heater should be supplied in order to maintain the hydraulic fluid at an ambient temperature above 30°F (—1°C.)

6.0 START UP PROCEDURE

The following start up procedure is complete and does repeat instructions on filling the gearbox and pump.

- 6.0.1 Remove backpressure spring, if any (anti-siphon spring, Part#100198 on Fig 3) for start-up. Reinstall after pump is operational if needed.
- 6.0.2 Flooded Suction: Refer to Section II, Paragraph 1.0.9, for instructions on filling gearbox with hydraulic fluid.
- 6.0.3 On initial start-ups: Set the pump capacity at 0%.

Check for proper motor rotation (Refer to Paragraph 1.0.6).

- 6.0.4 Open air bleed port (#51 on the drawing). Let all the air escape from the oil side. Keep it open until only oil comes out from the port. Close the port tight. Run pump for 10-15 seconds couple of times and listen for any abnormal motor or crank noises, and if present, refer to trouble shooting chart.

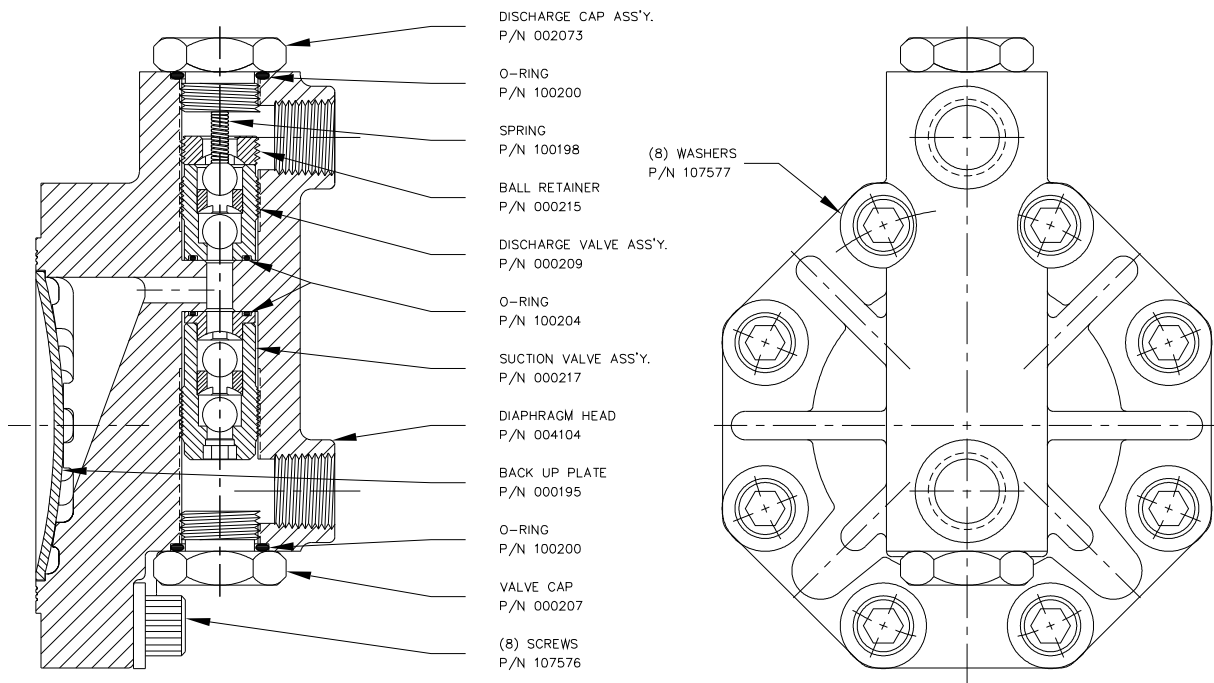

NOTE: Shown 6200 series pump. For 6100 series parts refer to parts list on pages 18 & 19.

FIGURE 3

6.0.5 Make sure that the pumping chamber is flooded by loosening Discharge Cap (Part #002073 on Fig 3) and allowing solution to appear. Then tighten Discharge Cap (Part #002073 on Fig 3). This procedure will also allow air to vent from pumping chamber. THE "dia-PUMP" WILL NOT FUNCTION IF AIR IS TRAPPED IN THE HYDRAULIC FLUID OR LIQUID INSIDE OIL PUMP CHAMBER.

6.0.6 After having let pump stand for 30 minutes and having rechecked fluid level, set pump capacity indicator at approximately 30%. Be certain that pump suction and discharge lines are open.

6.0.7 Start pump. Slowly adjust to the required capacity.

WARNING

BEWARE APPLICATIONS WHERE WATER IS NOT COMPATIBLE WITH CHEMICAL TO BE PUMPED. EXAMPLE: NEVER FORCE PRIME WHEN PUMPING ACID OR OIL BASED PRODUCTS.

SECTION III

NORMAL MAINTENANCE

7.0 MAINTENANCE

CAUTION - Ensure all operators are properly trained and employ safe operating and maintenance practices. Operator error may cause process liquid to expel through the head joints and/ or piping.

Under normal conditions, the "dia-Pump" should not require any significant amount of maintenance. It is advised that periodic visual observations be made of the oil level to make sure that it is over the worm gear. The liquid end of the pump should also be inspected for leakage. These observations should be made regularly.

The hydraulic fluid should be drained and replaced twice a year, using the drain plug (# 68 on Parts Drawing) at the back of the pump. This change can be scheduled with the normal factory maintenance at seasonal periods.

7.0.1 Check Valves: Removing, cleaning, replacing.

The "dia-Pump" incorporates a unique check valve design whereas the discharge and suction piping NEED NOT be disturbed in order to service the valves.

Should the valves need cleaning, remove as follows:

7.0.2 Remove discharge valve cap (# 002073 on Figure 3).

7.0.3 Remove ball retainer (# 000215 on Figure 3), using 5/16" Allen wrench.

7.0.4 Remove discharge valve cartridge (# 000209 on Figure 3). Using special wrench provided. Be certain that valve o-ring (# 100204 on Figure 3) is removed with valve cartridge.

7.0.5 Remove suction valve cap ((# 000207 on Figure 3).

7.0.6 Remove suction valve cartridge (# 000217 on Figure 3), using 5/16" Allen wrench. Be certain that valve o-ring (# 100204 on Figure 3) is removed with valve cartridge.

7.0.7 Clean valve cartridges with suitable solvent. The valve cartridge is a complete and integral unit and should not be disassembled for cleaning. If the valves are found to be worn and in need of replacement, an entire valve cartridge in either suction or discharge should be ordered. The suction valve is the longer of the two valve cartridges.

7.0.8 To replace reverse above procedure using a small amount of grease to hold valve o-rings in place. Do not over tighten the valve cartridges as this could damage the valve o-rings.

FOR THE FOLLOWING OPERATIONS REFER TO **PART DRAWINGS** ON PAGES 18 & 20

- 7.1.1 Procedure for replacing Control Rod o-ring (#50, 51 on Parts Drawing) and Sealing Plate "O" RING (#52 on Parts Drawing).
 - 7.1.2 Remove hydraulic fluid from gearbox.
 - 7.1.3 Remove indicator plate (#46 on Parts Drawing); by removing the two indicator plate screws (#45 on Parts Drawing)
 - 7.1.4 Remove control rod assembly with control rod attached for all pumps; (#42, #43, #44 and #53 on Parts Drawing) by turning counter clockwise until threads are disengaged, then pulling out.
 - 7.1.5 Remove sealing nut (#39 on Parts Drawing)
 - 7.1.6 Remove seal plate (#38 on Parts Drawing) using small brass hook to pry loose
 - 7.1.7 Replace control rod o-ring (#50 on Parts Drawing) & BACKUP RINGS (#51 on Parts Drawing)
 - 7.1.8 When replacing sealing plate take care so as to not shear the sealing plate o-ring and backup ring (#52 and #68 on Parts Drawing). Apply grease to o-rings before assembly. Take special care to place the outside backup ring (#68 on Parts Drawing) in the right place when replacing the outside "O" ring and backup ring.
 - 7.1.9 Replace balance of parts and fill pump with hydraulic fluid per previous instructions.
 - 7.1.10 Follow startup procedure as if starting a new pump. Refer to Section II, Paragraph 1.0.9 and 6.0.
- 7.2.1 Removal of pump-head and replacement of diaphragm.
 - 7.2.2 Remove drain plug (#67 on Parts Drawing), and drain hydraulic fluid.
 - 7.2.3 Remove pump head bolts and washers (#65 and #66 on Parts Drawing). Move pump head (#62 on Parts Drawing) away from pump.
 - 7.2.4 Remove and examine Teflon diaphragm (#47 on Parts Drawing). Remove and examine the liquid side diaphragm backup plate (#64 on Parts Drawing). Replace with new backup plate and Diaphragm, if required. When replacing the Teflon diaphragm, be certain to line it up properly with the sealing grooves.
 - 7.2.5 To reassemble reverse the above procedure. Laying the pump on its side facilitates reassembly. Be certain to tighten all bolts evenly. Tighten to 65 ft. lbs.

Recommended Maintenance Schedule
Weekly Interval
<ul style="list-style-type: none"> • Check oil level
<ul style="list-style-type: none"> • Check for leaks
<ul style="list-style-type: none"> • Check ground connection for corrosion
<ul style="list-style-type: none"> • Clean pump surfaces and surrounding area of dust and debris
First 250 hours of operation
<ul style="list-style-type: none"> • Change oil
Every 4000 hours or six months
<ul style="list-style-type: none"> • Change oil
<ul style="list-style-type: none"> • Clean inlet piping strainer & check external pressure relief valve
<ul style="list-style-type: none"> • Replace worm shaft oil seal
<ul style="list-style-type: none"> • If equipped, check coupling insert. Replace if necessary.
<ul style="list-style-type: none"> • Tighten all fasteners
Annual
<ul style="list-style-type: none"> • Clean check valves. Replace o-rings.
<ul style="list-style-type: none"> • Replace diaphragm
<ul style="list-style-type: none"> • If equipped, replace coupling insert.
<ul style="list-style-type: none"> • Replace rolling element bearings
<ul style="list-style-type: none"> • Replace o-rings
<ul style="list-style-type: none"> • Replace check valves
<ul style="list-style-type: none"> • Apply Anti-seize at motor shaft and gear shaft adapter.

SECTION IV

MOTOR OPERATING CONDITIONS

- 8.0 The normal temperature rise for standard motors is 40°C above ambient temperature and, thus, it might appear that the motor is operating at a higher than normal temperature. This situation is normal and should not cause concern.

Due to the high motor surface temperature (80°C), as a precaution to avoid burning skin, it is recommended to avoid touching the pump during operation. After shutting off pump, let the pump rest for 5 minutes before touching the motor.

As a precaution against motor overheating, it is recommended that the pump be located where adequate ventilation is available, It is also recommended that a MOTOR STARTER WITH THE PROPER OVERLOAD PROTECTION BE SUPPLIED AS AN ADDITIONAL SAFETY DEVICE.

SECTION V TROUBLE SHOOTING CHART

SYMPTOMS	CAUSES	REMEDIES
1. Pump Motor Will Not Operate.	A. Blown Fuse.	Check for short circuit or overload
	B. Open thermal overload device in starter.	Reset.
	C. Low liquid level in tank (where low level cut-off is used).	Fill tank.
	D. Broken wire.	Locate and repair.
	E. Low voltage.	Check for too light wiring.
	F. Oil "frozen" in pump.	Thaw out.
2. Pump Does Not Deliver Rated Capacity	A. Starved suction.	Replace suction piping with larger size.
	B. Leaky suction piping.	Pressure test, repair or replace defective piping.
	C. Excessive suction lift.	Rearrange equipment location to reduce suction lift.
	D. Liquid too close to boiling point.	Lower temperature or increase suction pressure slightly.
	Air or gas trapped in oil or chemical solution.	Decrease capacity to 20% for 7 mins. then increase to 100% for 7 mins. Bleed air from valve system
	E. Worn or dirty valves or seats, or both.	Clean or replace.
	F. Viscosity of liquid too high.	1. Reduce viscosity by heating or other means. 2. Increase size of suction piping 3. Increase suction pressure slightly
	G. Insoluble materials, crystallization or solids settling.	Limit solution strength to 5% by weight. Flush and clean solution tank periodically. Suction connection should be 2 to 4" from bottom of solution tank.
3. Pump delivers erratically.	H. Low discharge pressure.	A minimum discharge pressure of 50 psi is required to insure proper capacity control
	A. Leaky suction line.	Repair or replace piping.
	B. Worn or dirty valves or seats, or both.	Clean or replace valve assembly.
	C. Excessive excursion of ball valves from seats (indicated by ball chatter).	Increase backpressure.
	D. Insufficient suction pressure	Increase suction pressure. Raise tank level.
	E. Liquid too close to boiling point,	Reduce temperature or raise suction pressure.
	F. Leaky system relief valve.	Repair or replace relief valve
4. Motor overheats thermal overload activates,	G. Low hydraulic fluid level.	Add hydraulic fluid.
	A. Power supply does not match motor.	Check power supply against motor nameplate data.
5. Noisy Operation	B. Overload caused by operating pump beyond rated capacity	Check operating pressure against pump manufacturer data plate maximum rating
	1. In Pump	A. Pump Valves.
2. In Gear Reducer	A. Pounding noise at high discharge pressure.	Fluid compressibility causes reversal of load on gears at end of pressure stroke, Not considered detrimental.
6. Oil level overflows reservoir,	A. Flexible diaphragm punctured	Replace diaphragm and hydraulic fluid (drive lubricant) if contaminated.

SECTION VI

9.0 SPARE PARTS

9.0.1 Important—When ordering spare parts, please show MODEL NUMBER AND SERIAL NUMBER of pump for which parts are being ordered. This information can be found on a stainless steel nameplate riveted to the side of the pump.

9.0.2 Recommended Spare Parts (Spare parts Kit Part#004353)
It is recommended that the following parts be kept in stock for a pump:

ITEM#	PART#	DESCRIPTION	QTY.
47	004108	Teflon Diaphragm	1
52	100082	Sealing Plate o-ring	2
50	100323	Control Rod o-ring	2
51	106547	Control Rod Backup Ring	4
60	100204	Valve o-ring	8
56	100200	Discharge & Suction Cap o-ring	4
59	000209	Discharge Valve Cartridge	1
61	000217	Suction Valve Cartridge	1
68	108019	Sealing Plate Backup Ring	1

PARTS ORDERING INSTRUCTIONS

Note: For prompt entry of orders for this pump, your order must include both model number and serial number.

PRE-MOLDED DIAPHRAGM INSTALLATION

Starting in June 2023, Neptune has started to provide a pre-molded diaphragm to assist in the priming of the diaphragm. Please review the instructions below for the best method to install the diaphragm.

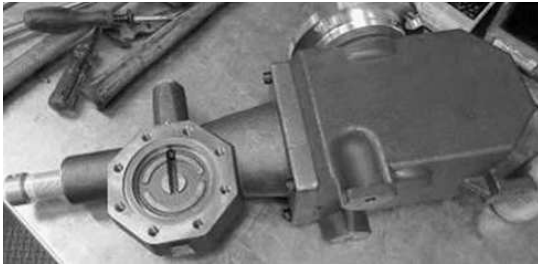

The pre-molded diaphragm is now in a dome shape instead of a flat shape. We recommend to lay the pump sideways during installation, which helps position the diaphragm at the center of the pump head.

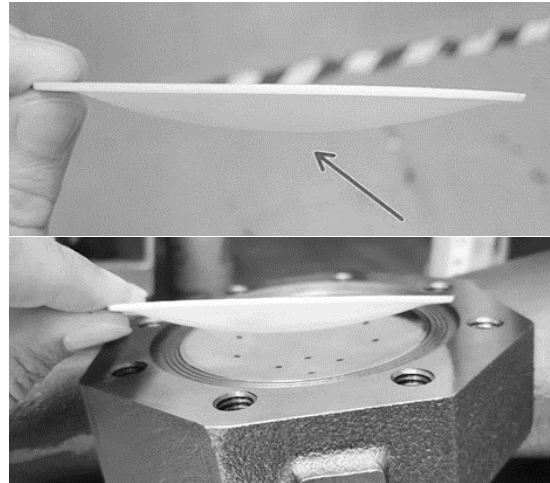

Identify the dome side of the pre-molded diaphragm (see arrow shown below). The dome side of the diaphragm should face the oil head (downward if following the instruction shown on the left) at installation. Failure to properly orient the diaphragm may lead to excessive priming time.

SERIES 6000 PUMP PARTS DRAWING
 (SHOWN HERE WITH 0.7500" PISTON)

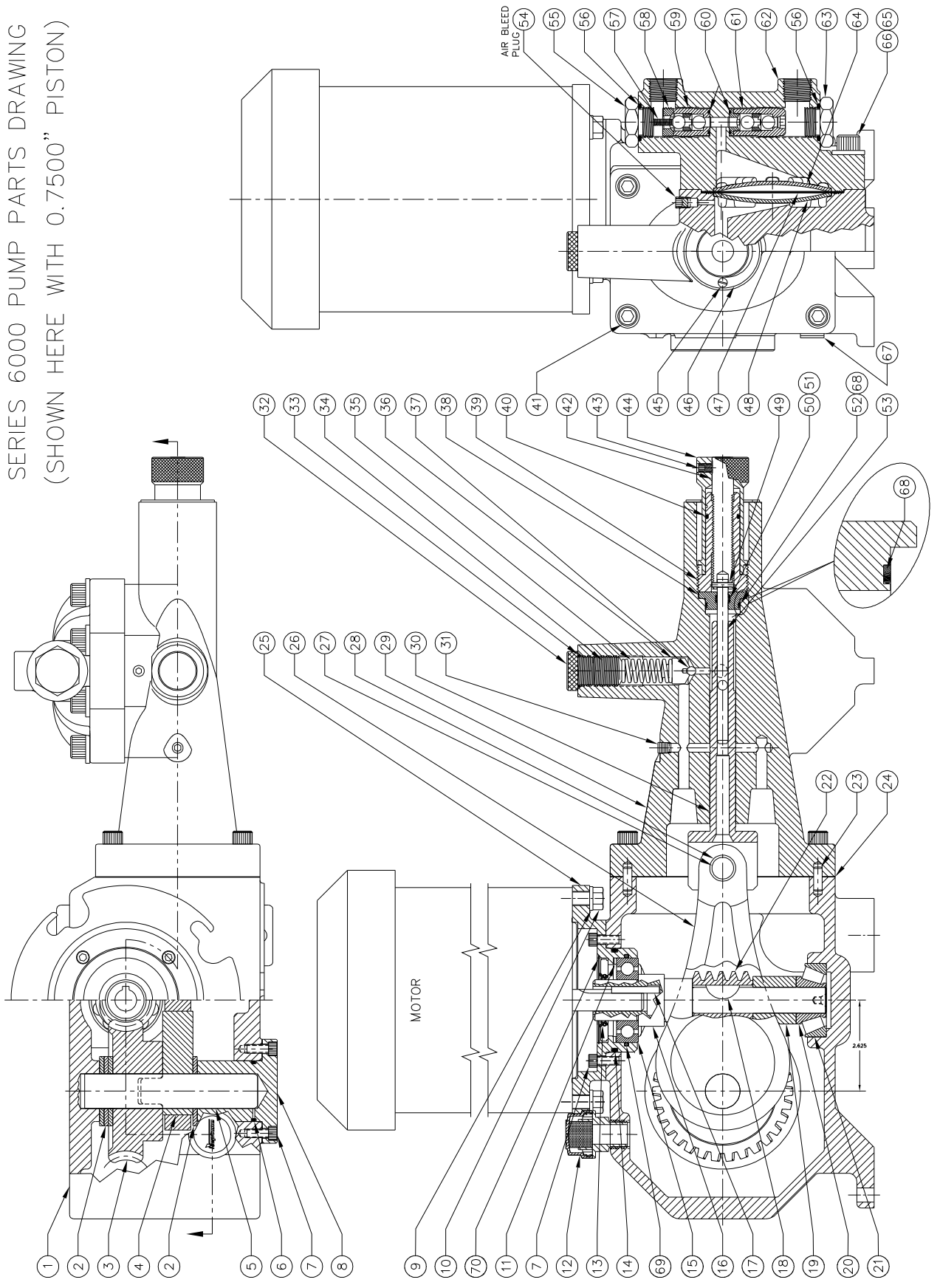

**PARTS LIST FOR PUMP MODELS 6100 to 6150
(REFER TO PART DRAWING ON PAGE 18)**

ITEM#	DESCRIPTION	QTY.	PART#
1	Gear Box	1	004089
2	Thrust Washers	4	107595
3	Worm Gear 58 SPM	1	004098
	Worm Gear 117 SPM	1	004099
4	Eccentric	1	004100
5	Gear Shaft	1	107598
6	Shaft Retainer O-Ring	1	107580
7	Gear Shaft Retainer Screws	7	100211
8	Gear Shaft Retainer	1	004094
9	3/8" Lock Washers	4	100217
10	3/8-16 X 1" lg. screws	4	100216
11	Wave Spring	1	107599
12	Fill/Vent Plug	1	000191
13	Oil Seal	1	128166
14	Motor Adapter O-Ring	1	107600
15	Ball Bearing	1	106180
16	Worm Shaft 58 SPM	1	004096
	Worm Shaft 117 SPM	1	004103
17	Motor Coupling Key	1	106589
18	Woodruff Key	1	107601
19	Worm Shaft Bushing	1	107736
20	Bearing Cone	1	107596
21	Bearing Cup	1	107597
22	Worm 58 SPM	1	107592
	Worm 117 SPM	1	107593
23	Spring Pin	2	100010
24	Gasket	1	107581
25	Motor Adapter	1	004095
26	Connecting Rod	1	004091
27	Connecting Rod Pin	1	100304
28	Connecting Rod Sleeve	1	000359
29	Oil Head 3/4" Dia.	1	005014

ITEM#	DESCRIPTION	QTY.	PART#
30	Piston 3/4" Dia.	1	004231
31	1/8 NPT Pipe Plug	1	100196
32	Relief Valve Cap	1	000365
33	Relief Valve Cap O-Ring	1	100200
34	Relief Valve Adjusting Screw	1	000364
35	Relief Valve Spring	1	100310
36	Relief Valve Ball Guide	1	000379
37	1/4" Dia. Ball	1	100559
38	Sealing Plate 3/4" & 1" pistons	1	004111
39	Sealing Nut	1	004102
40	Knob Friction O-Ring	1	100327
41	Pump/Head Screws	4	105082
42	Control Rod Screw	1	004093
43	Control Knob Screw	1	100308
44	Control Knob	1	004092
45	Indicator Plate Screws	2	100190
46	Indicator Plate	1	000188
47	Teflon Diaphragm	1	004108
49	Control Rod Spring Pin	1	100063
50	Control Rod O-Ring	1	100323
51	Control Rod Parbak Rings	2	106547
52	Sealing Plate O-Ring	1	100082
53	Control Rod, for 3/4" or 1" Piston	1	000385
54	Air Bleed Plug	1	100210
56	Valve Cap O-Rings	2	100200
60	Valve Seat O-Rings	2	100204
65	Pump Head Screws	8	131770
66	Washers	8	107577
67	Drain Plug	1	100300
68	Sealing Plate backup Ring	1	108019
69	"O" ring 62 mm	1	128165
70	Internal Retaining Ring	1	106592

PARTS FOR PUMPS WITH METAL HEADS

ITEM#	DESCRIPTION	QTY.	SST - PART NO.	C20 - PART NO.
55	Discharge Valve Cap	1	002073	002072
57	Anti-Siphon Spring	1	100198	100199
58	Discharge Valve Nut	1	000215	000216
59	Discharge Cartridge	1	000209	000210
61	Suction Valve Cartridge	1	000217	000218
62	Liquid Head	1	005012	005013
63	Suction Valve Cap	1	000207	000208
48 & 64	Diaphragm Back Up Plates, Oil & Liquid Sides.	2	005018	005019

SERIES 6200 PUMP PARTS DRAWING
 (SHOWN HERE WITH 1" PISTON)

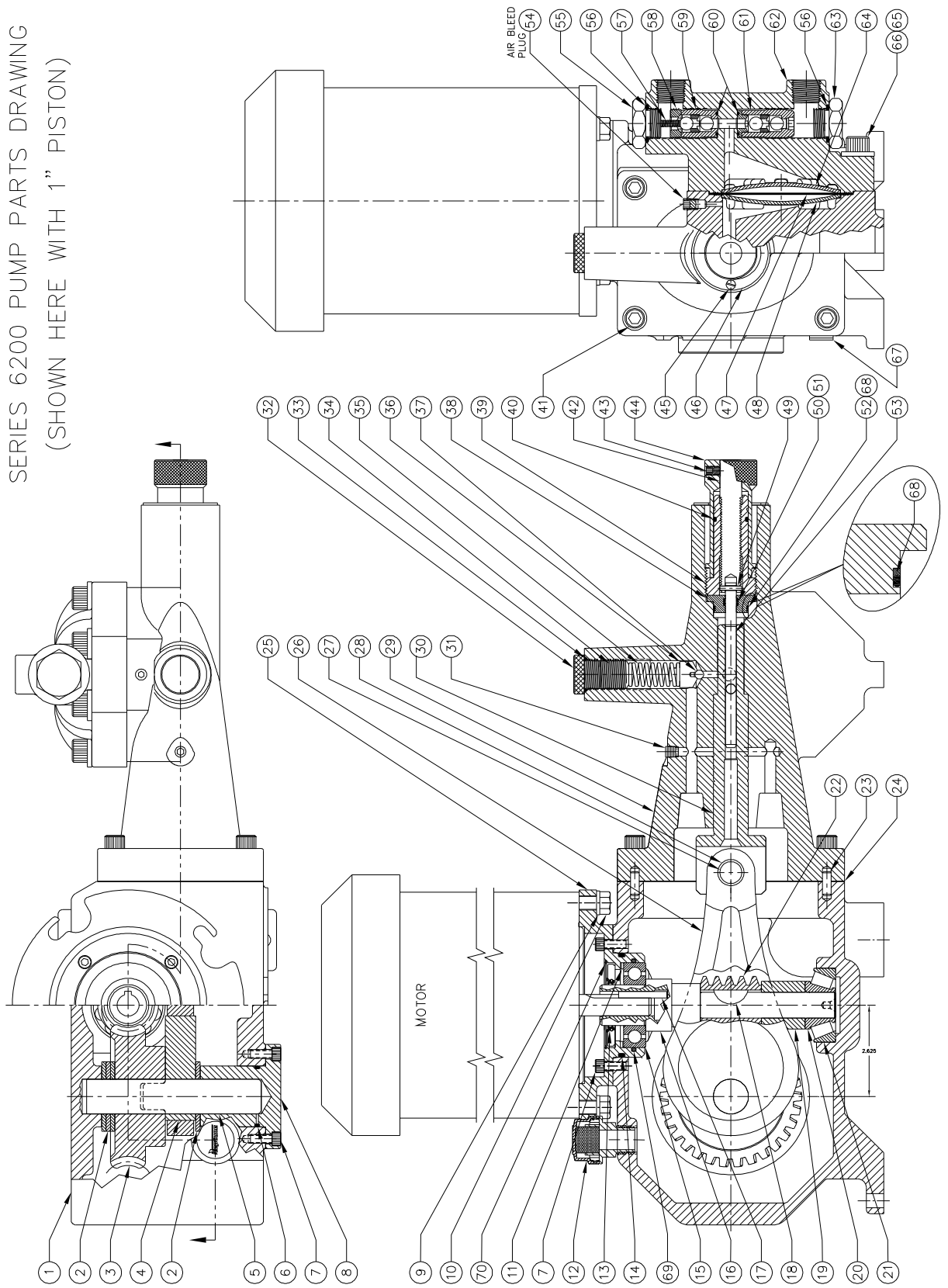

**PARTS LIST FOR PUMP MODEL 6250
(REFER TO PART DRAWING ON PAGE 20)**

ITEM#	DESCRIPTION	QTY.	PART#
1	Gear Box	1	004089
2	Thrust Washers	4	107595
3	Worm Gear 58 SPM	1	004098
	Worm Gear 117 SPM	1	004099
4	Eccentric	1	004100
5	Gear Shaft	1	107598
6	Shaft Retainer O-Ring	1	107580
7	Gear Shaft Retainer Screws	7	100211
8	Gear Shaft Retainer	1	004094
9	3/8" Lock Washers	4	100217
10	3/8-16 X 1" lg. screws	4	100216
11	Wave Spring	1	107599
12	Fill/Vent Plug	1	000191
13	Oil Seal	1	128166
14	Motor Adapter O-Ring	1	107600
15	Ball Bearing	1	106180
16	Worm Shaft 58 SPM	1	004096
	Worm Shaft 117 SPM	1	004103
17	Motor Coupling Key	1	106589
18	Woodruff Key	1	107601
19	Worm Shaft Bushing	1	107736
20	Bearing Cone	1	107596
21	Bearing Cup	1	107597
22	Worm 58 SPM	1	107592
	Worm 117 SPM	1	107593
23	Spring Pin	2	100010
24	Gasket	1	107581
25	Motor Adapter	1	004095
26	Connecting Rod	1	004091
27	Connecting Rod Pin	1	100304
28	Connecting Rod Sleeve	1	000359
29	Oil Head 1" Dia.	1	005015

ITEM#	DESCRIPTION	QTY.	PART#
30	Piston 1" Dia.	1	004232
31	1/8 NPT Pipe Plug	1	100196
32	Relief Valve Cap	1	000365
33	Relief Valve Cap O-Ring	1	100200
34	Relief Valve Adjusting Screw	1	000364
35	Relief Valve Spring	1	100310
36	Relief Valve Ball Guide	1	000379
37	1/4" Dia. Ball	1	100559
38	Sealing Plate 3/4" & 1" pistons	1	004111
39	Sealing Nut	1	004102
40	Knob Friction O-Ring	1	100327
41	Pump/Head Screws	4	105082
42	Control Rod Screw	1	004093
43	Control Knob Screw	1	100308
44	Control Knob	1	004092
45	Indicator Plate Screws	2	100190
46	Indicator Plate	1	000188
47	Teflon Diaphragm	1	004108
48	Oil Side Back-up Plate	1	000194
49	Control Rod Spring Pin	1	100063
50	Control Rod O-Ring	1	100323
51	Control Rod Parbak Rings	2	106547
52	Sealing Plate O-Ring	1	100082
53	Control Rod, for 3/4" or 1" Piston	1	000385
54	Air Bleed Plug	1	100210
56	Valve Cap O-Rings	2	100200
60	Valve Seat O-Rings	2	100204
65	Pump Head Screws	8	131770
66	Washers	8	107577
67	Drain Plug	1	100300
68	Sealing Plate backup Ring	1	108019
69	"O" ring 62 mm	1	128165
70	Internal Retaining Ring	1	106592

PARTS FOR PUMPS WITH METAL HEADS

ITEM#	DESCRIPTION	QTY.	SST - PART NO.	C20 - PART NO.
55	Discharge Valve Cap	1	002073	002072
57	Anti-Siphon Spring	1	100198	100199
58	Discharge Valve Nut	1	000215	000216
59	Discharge Cartridge	1	000209	000210
61	Suction Valve Cartridge	1	000217	000218
62	Liquid Head	1	004104	004106
63	Suction Valve Cap	1	000207	000208
64	Diaphragm Back Up Plate, Liquid Side	1	000195	000196

SECTION VII

SPECIAL INSTRUCTIONS FOR SERIES 6000 “dia-PUMPS” WITH ELECTRONIC STROKE CONTROL MODEL #SM-1020

Neptune Electronic Stroke Control Unit adjusts the capacity of the 6000 Series Pump over its full operating range by changing the stroke length in response to an external signal. Manual hand crank is optional.

Neptune Electronic Stroke Control consists of a Linear Actuator with required fittings and Adapters needed to mount the Actuator on a Neptune 6000 Series Pump. The stroke control is mounted to the pump prior to shipment.

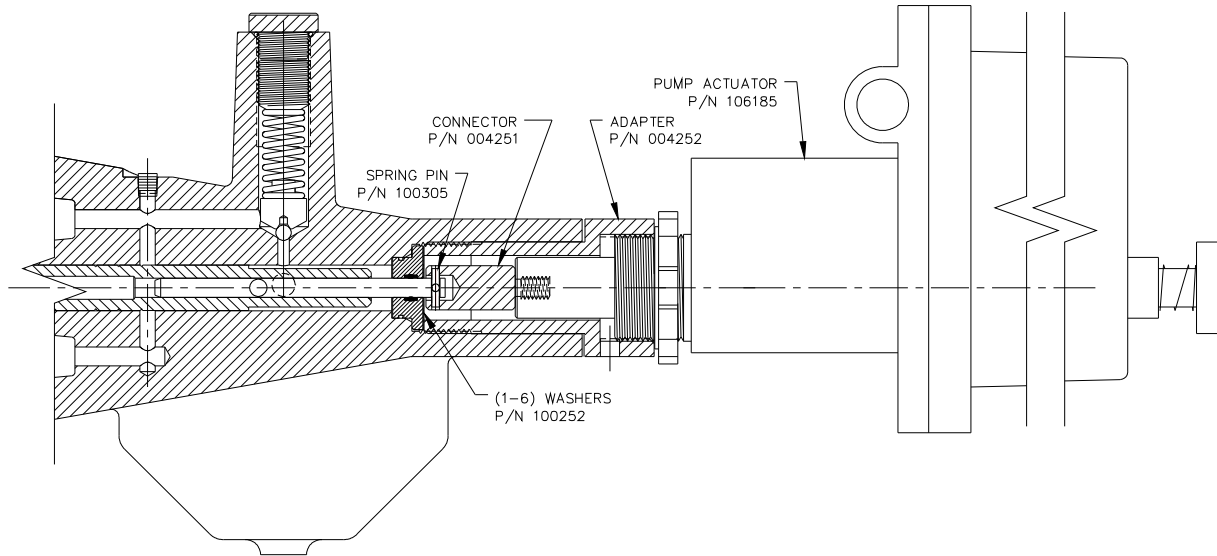

Drawing #004253

An optional Remote Control Station is available for use with the Stroke Control to permit remote Manual control and Remote indication of the Pump capacity settings.

For installation, Calibration setting, maintenance and troubleshooting, see “NEPTUNE ELECTRONIC STROKE CONTROL INSTRUCTION manual”.

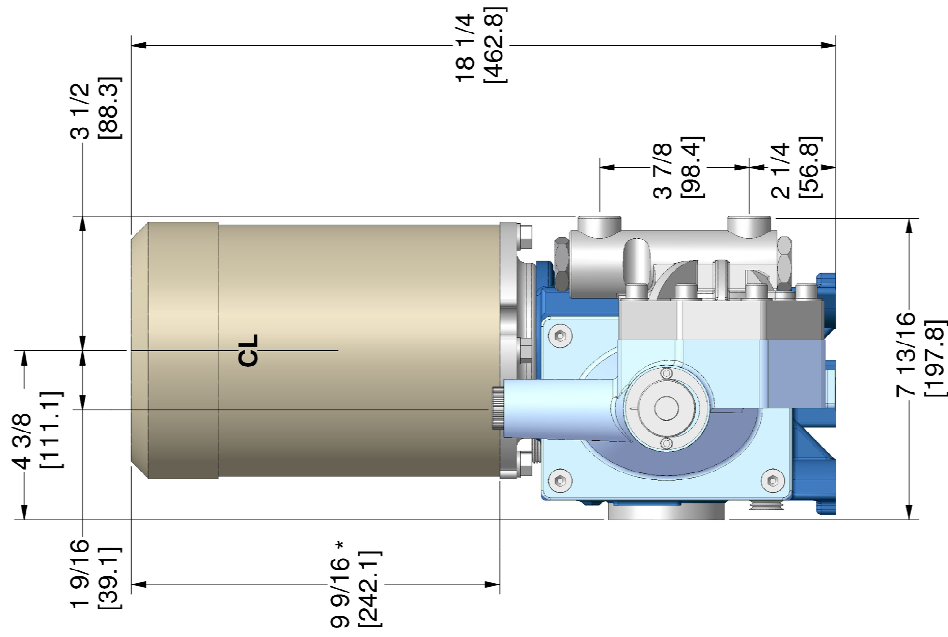

* MOTOR DIMENSION CHANGES WITH MOTOR TYPE

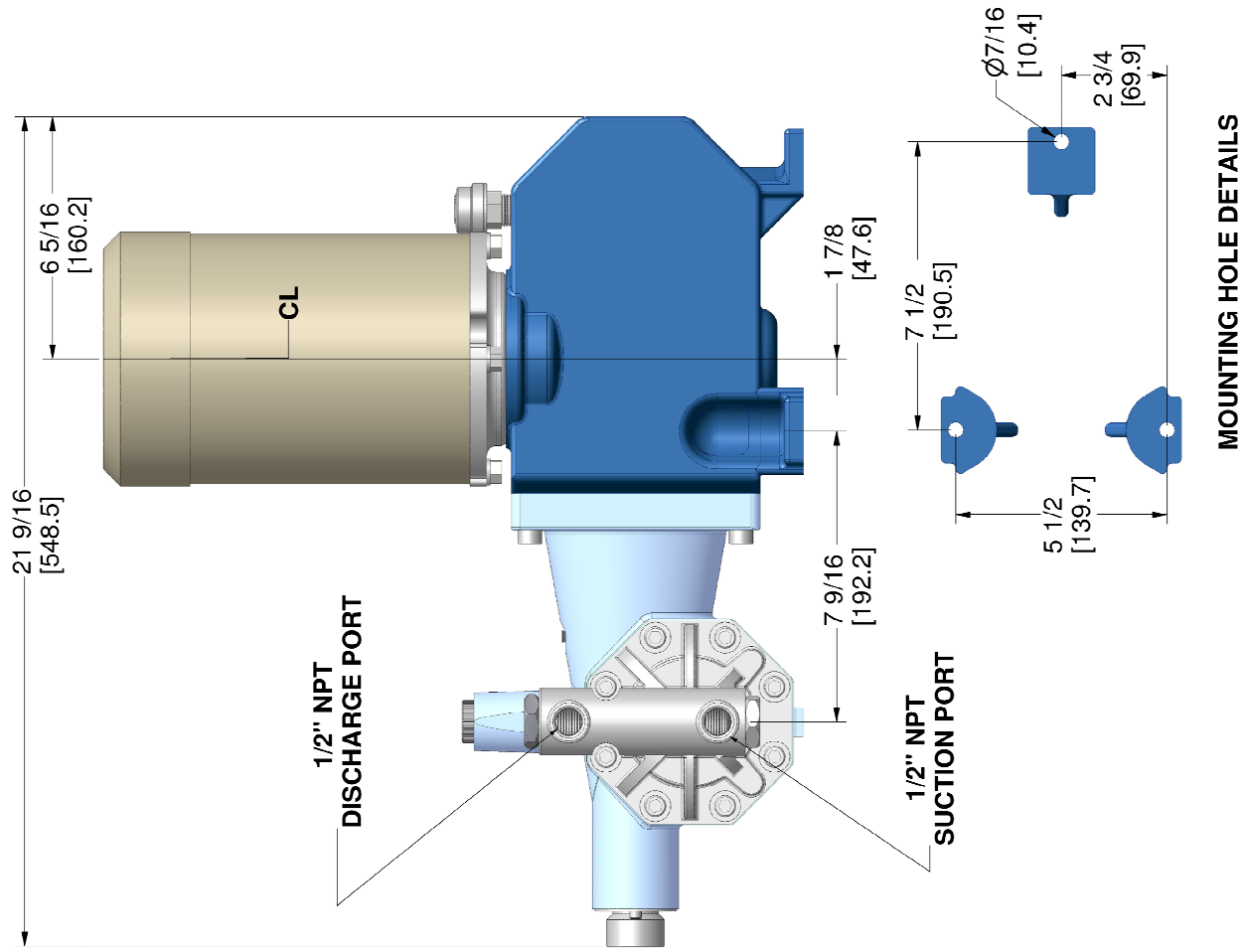

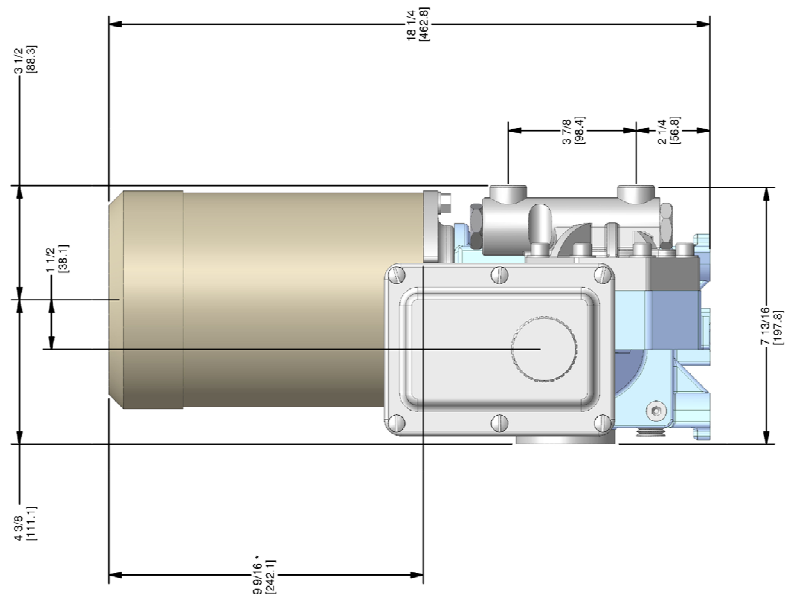

* MOTOR DIMENSION CHANGES WITH MOTOR TYPE

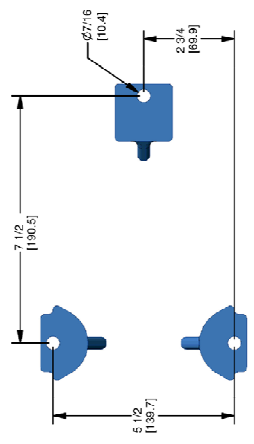
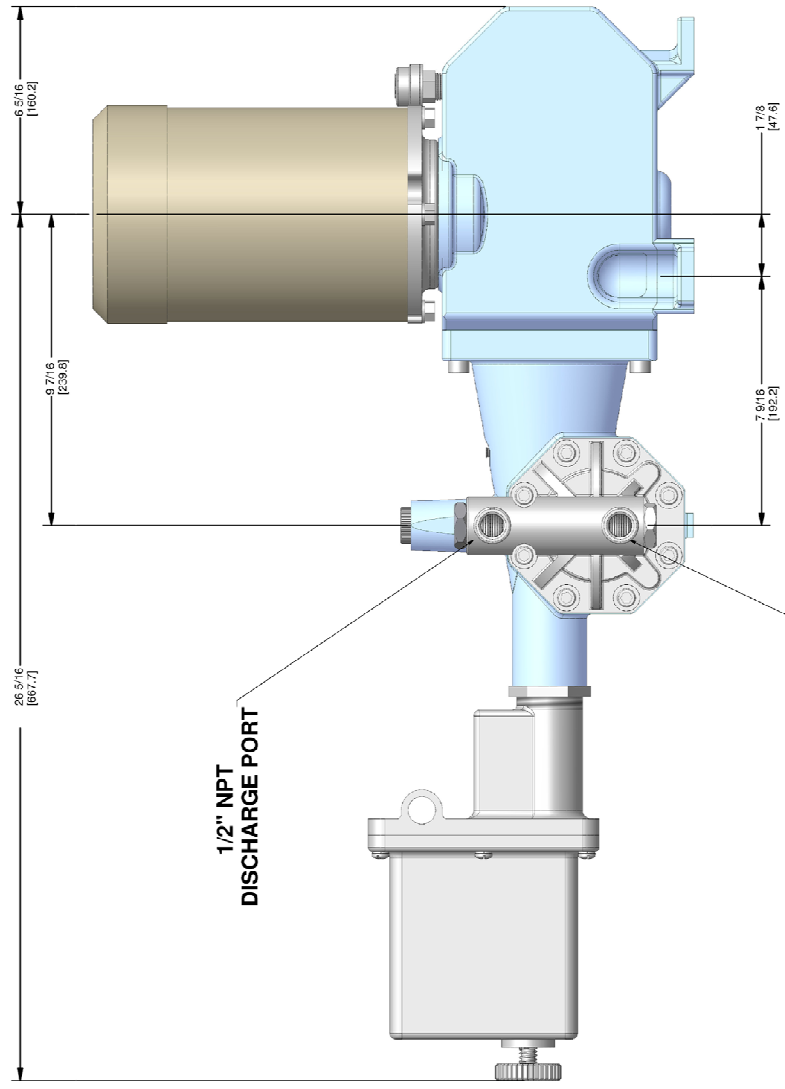

MOUNTING HOLE DETAILS

SECTION IX DOUBLE DIAPHRAGM OPTION

Special Instructions for Series 6000 “dia-Pumps” with Double Diaphragm

The instructions below are for Neptune’s optional Double Diaphragm Kit.

Use of a double diaphragm allows diaphragms to be monitored and provides an early warning upon failure of either diaphragm allowing repairs to be made before process fluid can mix with the pump’s hydraulic fluid.

Neptune’s double diaphragm is a kit, which may be retrofitted to any pump currently in service or may be installed on a new pump at the factory.

Figure 4, illustrates a Double Diaphragm Assembly. An intermediate plate is located between the oil and liquid heads with one diaphragm on each side of the intermediate plate. The Intermediate Plate is connected to a rupture alarm or pressure switch via a capillary system. The area between the diaphragms is evacuated. Rupture in either diaphragm produces an increase in volume and, therefore, a pressure increase, which can be sensed by a pressure switch for alarm purposes.

DISASSEMBLY OF INTERMEDIATE PLATE

- 11.0.0 Shut pump off and disconnect suction and discharge piping. Remove drain plug and drain hydraulic fluid from the gearbox.
- 11.0.1 Remove 8 Screws and remove the liquid head assembly. Some hydraulic oil and process fluid will spill out when the head is removed.
- 11.0.2 The intermediate plate, which is between the pump heads can be removed easily.
- 11.0.3 Remove the rupture alarm (pressure switch) and clean the capillary system.
- 11.0.4 Replace one or both diaphragms if needed.
- 11.0.5 To reassemble reverse above procedure. Be certain that parts align properly.

VACUUM AIR FROM INTERMEDIATE SPACE

- 11.0.6 Open valve Item No. 5 (Figure 5).
- 11.0.7 To remove air, attach the vacuum pump with a hose connection Item No. 6 to the valve Item No. 5 (Figure 5) and pump **until resistance is felt**, for normal operating conditions.
- 11.0.8 Close valve Item No. 5 (Figure 5).

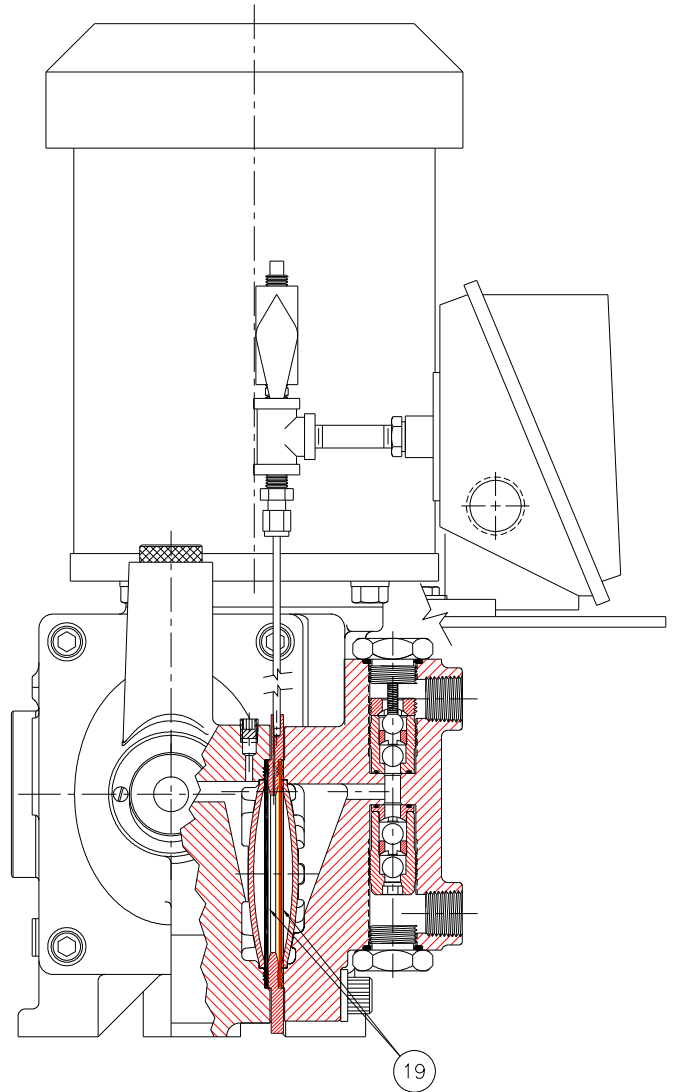
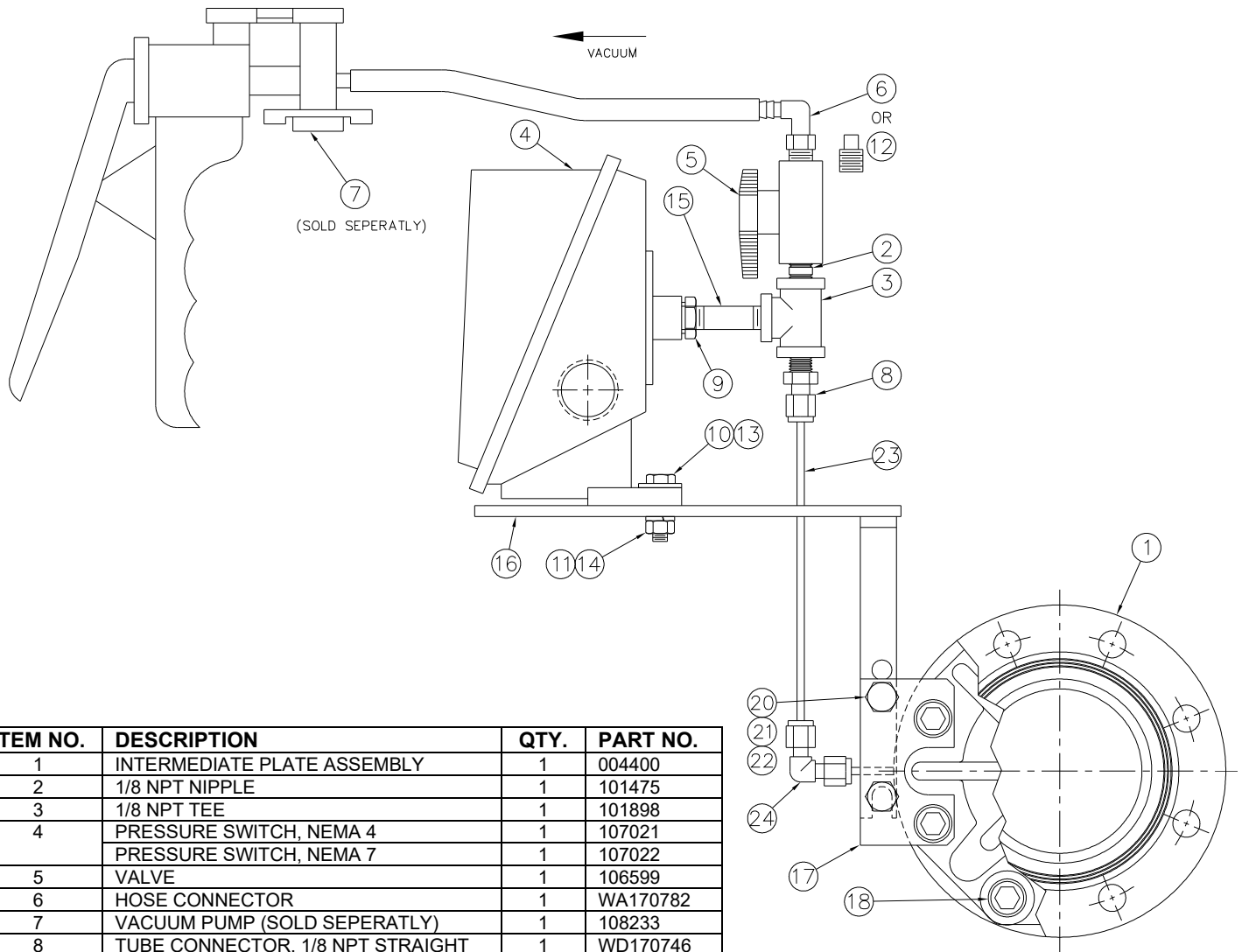

FIGURE 4

Remove the vacuum pump. Plug valve Item No. 5 with a 316SS pipe plug Item No. 12 (Figure 5)

11.0.9 Reinstall the Pump

11.0.10 Follow procedure in Neptune Standard Operating and Instruction Manual for Initial Pump Startup



ITEM NO.	DESCRIPTION	QTY.	PART NO.
1	INTERMEDIATE PLATE ASSEMBLY	1	004400
2	1/8 NPT NIPPLE	1	101475
3	1/8 NPT TEE	1	101898
4	PRESSURE SWITCH, NEMA 4	1	107021
	PRESSURE SWITCH, NEMA 7	1	107022
5	VALVE	1	106599
6	HOSE CONNECTOR	1	WA170782
7	VACUUM PUMP (SOLD SEPERATLY)	1	108233
8	TUBE CONNECTOR, 1/8 NPT STRAIGHT	1	WD170746
9	1/4 X 1/8 NPT REDUCER BUSHING	1	101804
10	1/4-20 X 1" LG. HEX HEAD SCREW	2	100159
11	1/4-20 HEX NUT	2	100448
12	1/8 NPT PIPE PLUG, 316SS	1	101859
13	1/4" FLAT WASHER	2	108426
14	1/4" LOCK WASHER	2	100169
15	1/8 NPT NIPPLE (FOR METAL HEADS)	1	101477
16	BRACKET ASSEMBLY	1	003577
17	SUPPORT BRACKET ADAPTER	1	004402
18	7/16-14 X 2-1/4" LG. S.H.C. SCREW	8	104515
19	DIAPHRAGM	2	000200
20	5/16-18 X 3/4" LG. HEX HEAD BOLT	2	100068
21	5/16" LOCK WASHER	2	100170
22	5/16-18 HEX NUT	2	108175
23	VACUUM TUBE	1	004433
24	TUBE CONNECTOR, 1/8 NPT ELBOW	1	104614

FIGURE 5

NOTE: Neptune furnishes a Mityvac[®] vacuum pump from Mityvac[®] No. 6810 automotive test kit available at many automotive parts store. (Unit furnished by Neptune is less gage and automotive adapters



EC Declarations for Diaphragm Metering Pumps

Manufacturer:
PSG California
22069 Van Buren Street
Grand Terrace, CA 92313 USA
Director of Engineering: Chris Distaso

Signature:

Representative authorized to compile technical files in the European Community:
ALMATEC Maschinenbau GmbH
Carl-Friedrich-Gauß-Straße 5
D - 47475 Kamp-Lintfort Germany
General Manager: Rainer Wulf

Signature:

Product: Neptune Diaphragm Metering Pump Models Series 400, 500, 600, 6000, 7000
Date: 05/22/2019
Serial Number: As Applicable

DECLARATION OF INCORPORATION (Valid for pumps supplied without a motor)

Neptune declares that the products listed above comply with the essential health and safety requirements relevant to the specific product as follows: All Neptune products listed above conform to the Machinery Directive 2006/42/EC: Part 1 of Annex I and comply with the relevant requirements of EN ISO 12100 Safety of Machinery - General Principles for Design - Risk Assessment and Risk Reduction, and DIN EN 809 Pumps and Pump Units for Liquids - Common Safety Requirements.

This subassembly is incomplete and must not be put into service until the machinery into which it is to be incorporated has been declared in conformity with the provisions of Directive 2006/42/EC ("The Machinery Directive") and any other applicable Directives.

DECLARATION OF CONFORMITY (Valid for pumps supplied with a motor)

Neptune declares that the products listed above comply with the essential health and safety requirements relevant to the specific product as follows: All Neptune products listed above conform to the Machinery Directive 2006/42/EC: Part 1 of Annex I and comply with the relevant requirements of EN ISO 12100 Safety of Machinery - General Principles for Design - Risk Assessment and Risk Reduction, DIN EN 809 Pumps and Pump Units for Liquids - Common Safety Requirements, and DIN EN ISO 4871 - Declaration and Verification of Noise Emission Values of Machinery and Equipment. The supplied motor conforms to the 2014/35/EU - The Low Voltage Directive (compliance exists from the motor manufacturer).

This product **may not be used** in an explosive environment.

MAINTENANCE LOG

Pump Model _____

Serial # _____

Strokes Per Minute _____

Maximum Flow _____

Piston Diameter _____

Maximum Pressure _____

Spare Parts Kit # _____

NEPTUNE CHEMICAL PUMP CO., INC. Tel.: 215-699-8700 • FAX: 215-699-0370

DATE	SERVICED BY	MAINTENANCE PERFORMED